

1.2V 350mA Low Dropout Linear Regulator

■ Features

- Fixed 1.2V ± 2% output voltage
- Fast transient response
- Output current limiting
- Built-in thermal shutdown
- Good noise rejection
- Packages: SOT23-3L

■ Applications

- PC peripheral
- Communication

■ General Description

AX1112 is a low dropout positive fixed-mode regulator with minimum of 350mA output current capability. The product is specifically designed to provide well-regulated supply for low voltage IC applications such as high-speed bus termination and low current 3.3V logic supply. AX1112 is also well suited for other applications such as VGA cards. AX1112 is guaranteed to have lower than 1.2V dropout at full load current making it ideal to provide well-regulated outputs.

■ Ordering Information

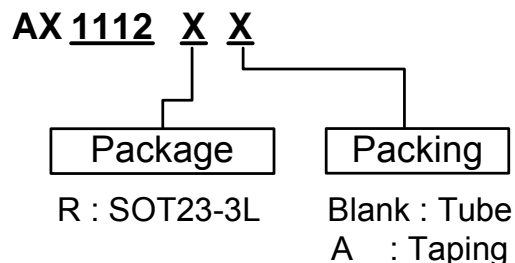

■ Typical Circuit

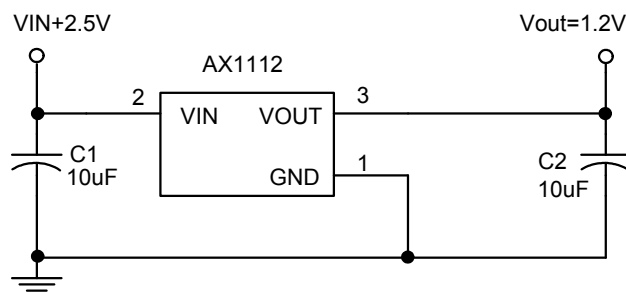

■ Connection Diagram

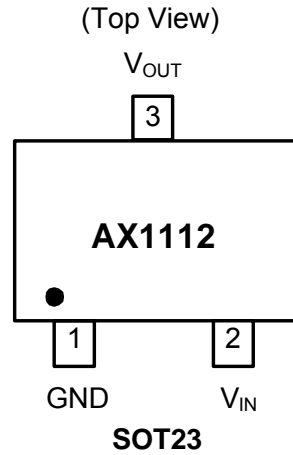

■ Marking Information



■ Block Diagram

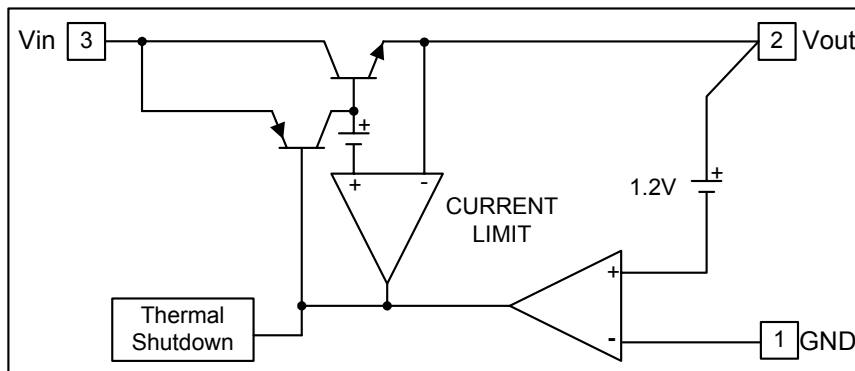

■ Pin Descriptions

NAME	I/O	PIN #	FUNCTION
Adj (GND)	I	1	A resistor divider from this pin to the Vout pin and ground sets the output voltage. (Ground only for Fixed-Mode)
Vout	O	2	The output of the regulator. A minimum of 10uF capacitor ($0.15\Omega \leq \text{ESR} \leq 20\Omega$) must be connected from this pin to ground to insure stability.
Vin	I	3	The input pin of regulator. Typically a large storage capacitor ($0.15\Omega \leq \text{ESR} \leq 20\Omega$) is connected from this pin to ground to insure that the input voltage does not sag below the minimum dropout voltage during the load transient response. This pin must always be 1.4V higher than Vout in order for the device to regulate properly.

■ Absolute Maximum Ratings

Symbol	Parameter	Rating	Unit
Vin	DC Supply Voltage	-0.3 to 15	V
T _{OP}	Operating Junction Temperature Range	0 to +125	°C
T _{MJ}	Maximum junction Temperature	150	°C
P _D	Power Dissipation (multi-layer PCB copper area 2mm*2mm) $T_A=25^\circ\text{C}$, $T_J=125^\circ\text{C}$ SOT-23	450	mW
T _{ST}	Storage Temperature	-65 to +150	°C

■ **Electrical Characteristics** (Under Operating Conditions)

PARAMETER	CONDITIONS	MIN	TYP	MAX	UNIT
Operation Input Voltage	$I_{OUT} = 350\text{mA}$	2.5	-	12	V
Reference Voltage	$I_{OUT} = 10\text{mA}, 2.5 \leq V_{IN} \leq 12\text{V}, T_J = 25^\circ\text{C}$	1.176	1.200	1.224	V
Line Regulation	$I_{OUT} = 10\text{mA}, 2.5 \leq V_{IN} \leq 12\text{V}, T_J = 25^\circ\text{C}$ (Note 1,2)	-	1.2	6	mV
Load Regulation	$V_{IN}=2.5\text{V}, 10\text{mA} < I_O < 350\text{mA}, T_J=25^\circ\text{C}$ (Note 1,2)	-	-	12	mV
Dropout Voltage ($V_{IN}-V_{OUT}$)	$I_{OUT} = 350\text{mA}, \Delta V_{OUT}=1\%V_{OUT}$	-	1.1	1.2	V
Current Limit	$(V_{IN}-V_{OUT}) = 2\text{V}$	0.5	-	-	A
Minimum Load Current	$0^\circ\text{C} \leq T_J \leq 125^\circ\text{C}$	-	5	10	mA
Ripple Rejection	$F=120\text{Hz}, C_{OUT}=25\mu\text{F Tantalum}, I_{OUT}=350\text{mA}$	-	60	70	dB
Temperature Stability	$I_O=10\text{mA}$	-	0.5	-	%
θ_{JA} Thermal Resistance Junction-to-Ambient (Note4)	SOT-23	-	220	-	$^\circ\text{C/W}$
θ_{JC} Thermal Resistance Junction-to-Case	SOT-23	-	120	-	$^\circ\text{C/W}$

Note1: See thermal regulation specifications for changes in output voltage due to heating effects. Line and load regulation are measured at a constant junction temperature by low duty cycle pulse testing. Load regulation is measured at the output lead = 1/18" from the package.

Note2: Line and load regulation are guaranteed up to the maximum power dissipation of 5W. Power dissipation is determined by the difference between input and output differential and the output current. Guaranteed maximum power dissipation will not be available over the full input/output range.

Note3: Quiescent current is defined as the minimum output current required in maintaining regulation. At 12V input/output differential the device is guaranteed to regulate if the output current is greater than 10mA.

Note4: Vout Pin is connected to the multi-layer PCB copper area 2mm*2mm.

Typical Performance Characteristics

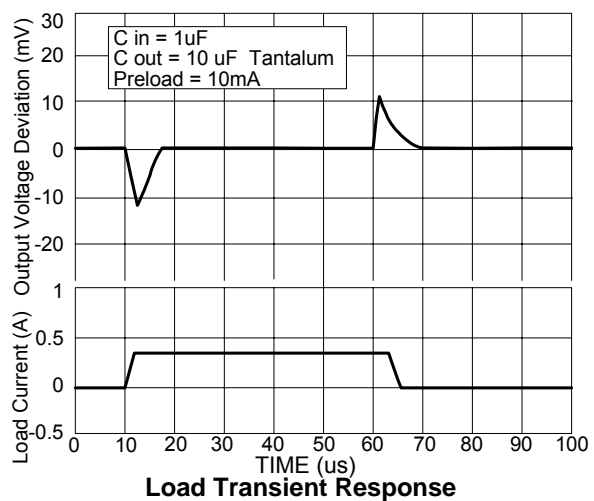
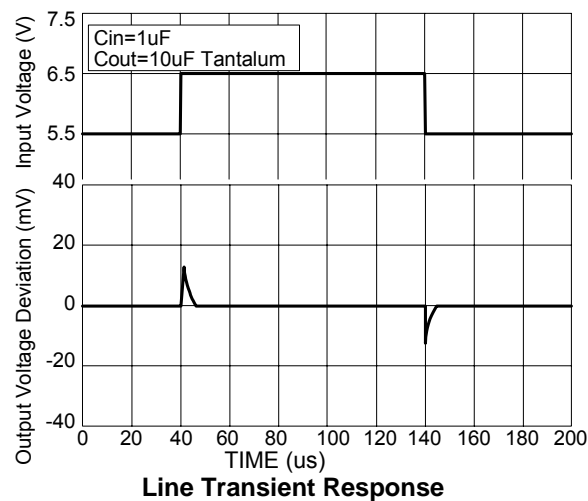
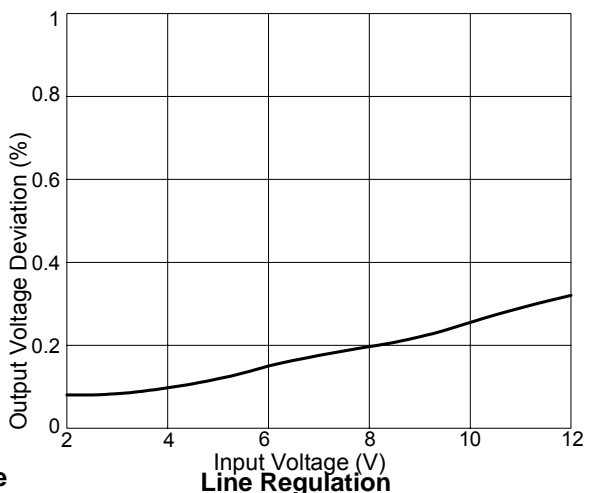
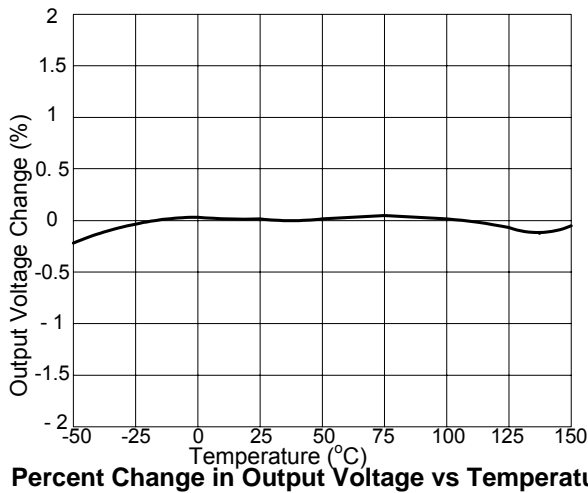
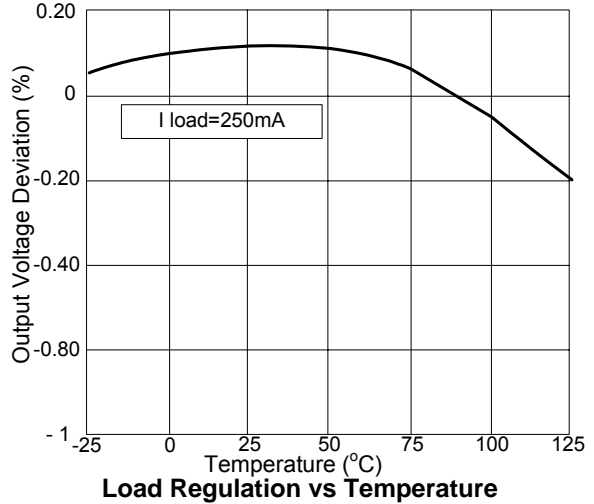
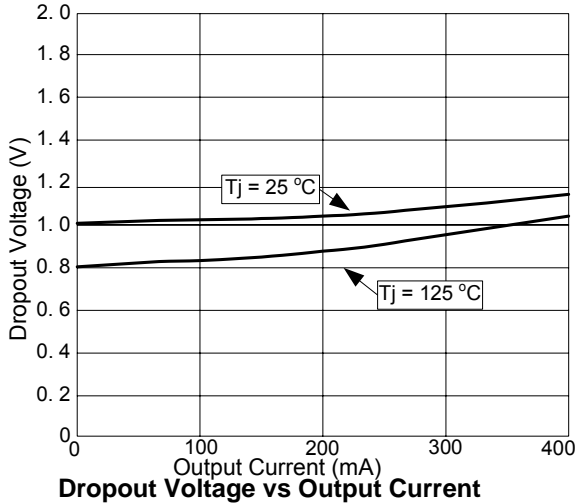

■ Package Dimension

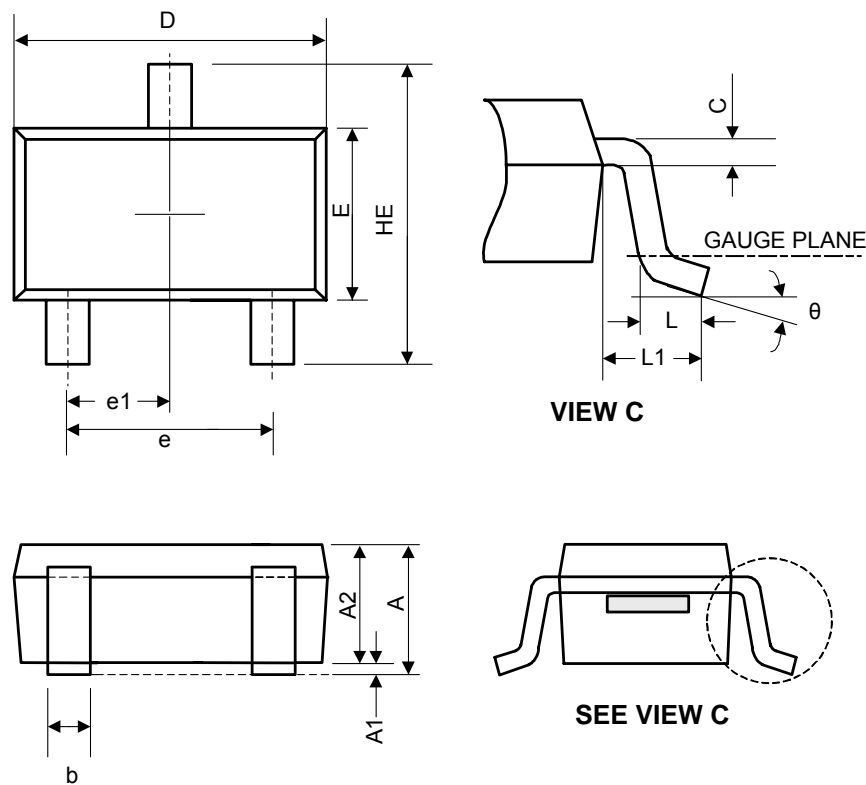

Symbol	Dimensions In Millimeters			Dimensions In Inches		
	Min.	Nom.	Max.	Min.	Nom.	Max.
A	1.05	-	1.35	0.041	-	0.053
A1	0.05	-	0.15	0.002	-	0.006
A2	1.00	1.10	1.20	0.039	0.043	0.047
b	0.25	-	0.50	0.010	-	0.020
C	0.08	-	0.20	0.003	-	0.008
D	2.70	2.90	3.00	0.106	0.114	0.118
E	1.50	1.60	1.70	0.059	0.063	0.067
HE	2.60	2.80	3.00	0.102	0.110	0.118
L	0.30	-	0.60	0.012	-	0.024
L1	0.50	0.60	0.70	0.020	0.024	0.028
e	1.80	1.90	2.00	0.071	0.075	0.079
e1	0.85	0.95	1.05	0.033	0.037	0.041
θ	0°	5°	10°	0°	5°	10°