

Dual Channel LDO Regulators with Enable

❖ GENERAL DESCRIPTION

The AX6604/5 is a high accurately, low noise, high ripple rejection ratio, low dropout, dual CMOS LDO voltage regulators with enable function. The EN function allows the output of each regulator to be turned off independently, resulting in greatly reduced power consumption.

The AX6604/5 has the soft start function to suppress the inrush current. The current limit is over 250mA per channel and also operates as a short protection for the output current limiter. The output voltage for each regulator is set independently by metal trimming.

The AX6604/5 is fully compatible with low ESR ceramic capacitors, reducing cost and improving output stability. This high level output stability is maintained even during frequent load fluctuations, due to the excellent transient response performance and high PSRR achieved across a broad range of frequency. It is available in the SOT-23-6L package.

❖ FEATURES

- Input voltage range :2.5V to 6V
- Varied fixed output voltage combinations
- 150mV Dropout at 100mA output current ($V_{OUT} \geq 2.8V$)
- Output current: 200mA/channel (typ.)
- Low quiescent current
- Standby Current: 1uA (typ.)
- Current Limit and Short current protections
- Thermal shutdown protection
- Fast transient response
- Low ESR Capacitor Compatible (X7R, X5R)
- Available in the 6-Pin Pb-Free SOT-23 package

❖ **BLOCK DIAGRAM**

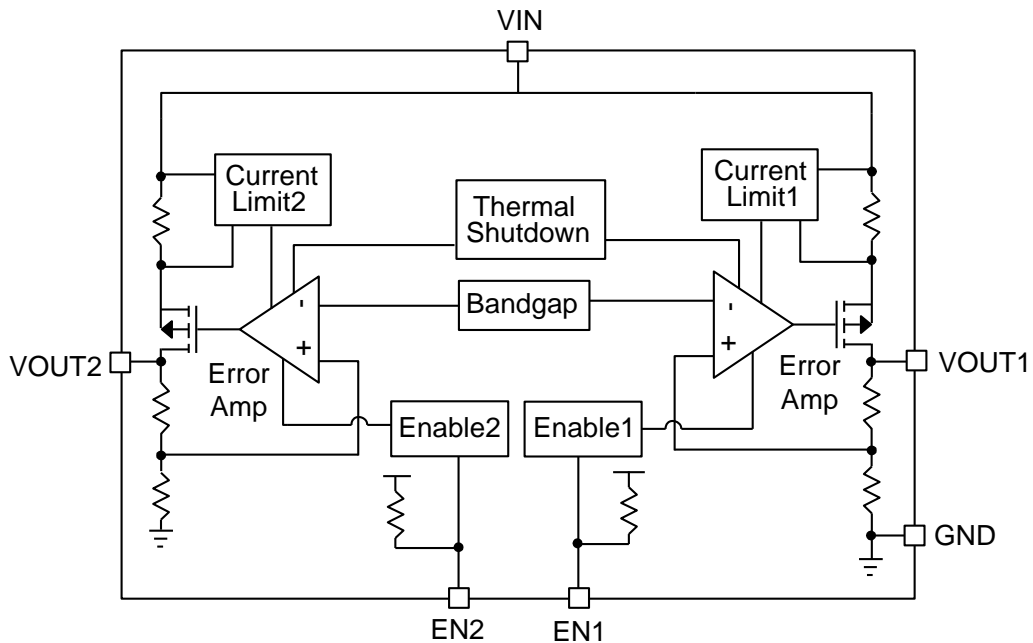

❖ **PIN ASSIGNMENT**

The package of AX6604/5 is SOT-23-6L; the pin assignment is given by:

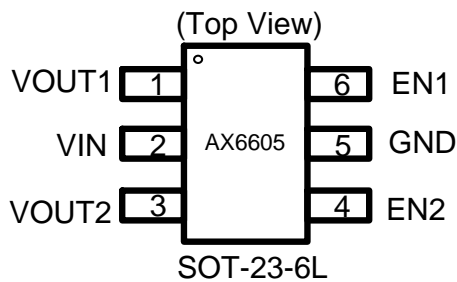
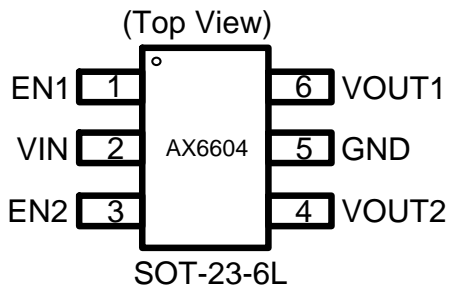

| Name | Description |
|--------------|--------------------------|
| VIN | Power input |
| GND | Ground |
| EN1 | Vout1 Enable Control Pin |
| EN2 | Vout2 Enable Control Pin |
| VOUT1 | Output1 Voltage |
| VOUT2 | Output2 Voltage |

❖ ORDER/MARKING INFORMATION

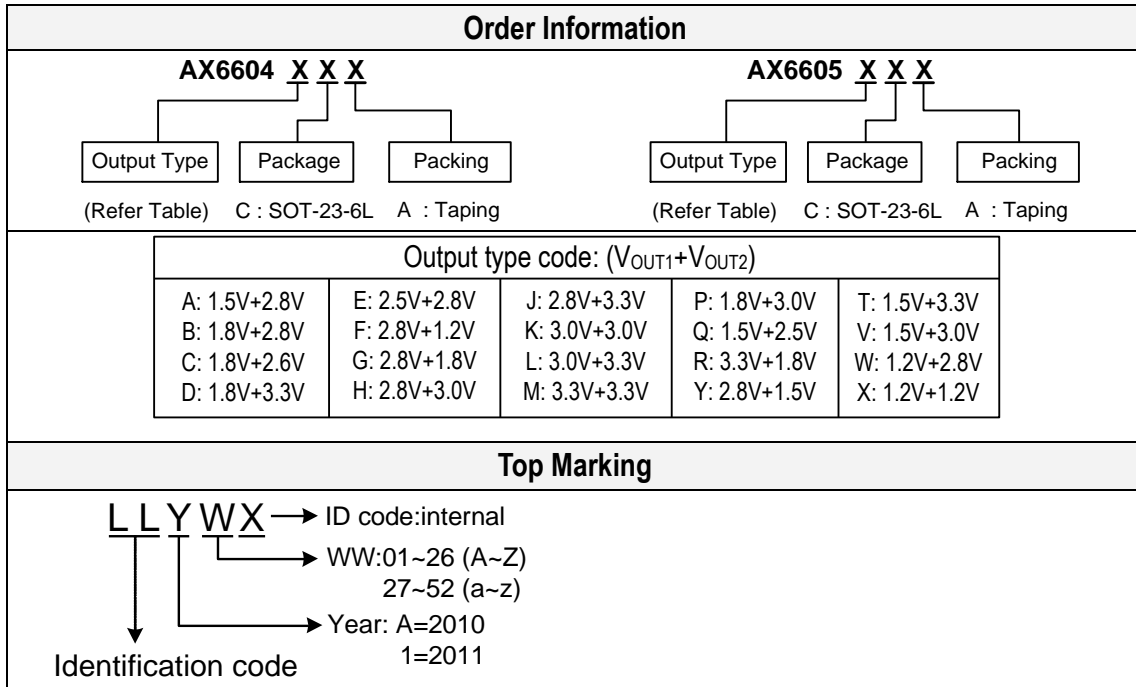

Appendix

| Part Number | Identification code |
|-------------|---------------------|
| AX6604ACA | LA |
| AX6604BCA | LB |
| AX6604CCA | LC |
| AX6604DCA | LD |
| AX6604ECA | LE |
| AX6604FCA | LF |
| AX6604GCA | LG |
| AX6604HCA | LH |
| AX6604JCA | LJ |
| AX6604KCA | LK |
| AX6604LCA | LL |
| AX6604MCA | LM |
| AX6604PCA | LP |
| AX6604QCA | LQ |
| AX6604RCA | LR |
| AX6604YCA | LS |
| AX6604TCA | LT |
| AX6604VCA | LU |
| AX6604WCA | LV |
| AX6604XCA | LW |

| Part Number | Identification code |
|-------------|---------------------|
| AX6605ACA | La |
| AX6605BCA | Lb |
| AX6605CCA | Ld |
| AX6605DCA | Le |
| AX6605ECA | Lf |
| AX6605FCA | Lg |
| AX6605GCA | Lh |
| AX6605HCA | Lj |
| AX6605JCA | Lm |
| AX6605KCA | Ln |
| AX6605LCA | Lq |
| AX6605MCA | Lr |
| AX6605PCA | Ls |
| AX6605QCA | Lt |
| AX6605RCA | Lu |
| AX6605YCA | Lw |
| AX6605TCA | Lx |
| AX6605VCA | Ly |
| AX6605WCA | L2 |
| AX6605XCA | L3 |

❖ ABSOLUTE MAXIMUM RATINGS (at $T_A=25^{\circ}\text{C}$)

| Characteristics | Symbol | Rating | Unit |
|---|---------------------|-----------------------------|-----------------------------|
| V_{IN} Pin Voltage | V_{IN} | GND - 0.3 to + 6.5 | V |
| Output Current | $I_{OUT1}+I_{OUT2}$ | 700 | mA |
| Output Voltage | V_{OUT1}/V_{OUT2} | GND - 0.3 to $V_{IN} + 0.3$ | V |
| Enable Voltage | EN1/EN2 | GND - 0.3 to $V_{IN} + 0.3$ | V |
| Power Dissipation | PD | 250 | mW |
| Storage Temperature Range | T_{ST} | -40 to +150 | $^{\circ}\text{C}$ |
| Operating Temperature Range | T_{OP} | -40 to +85 | $^{\circ}\text{C}$ |
| Junction Temperature | T_J | -40 to +125 | $^{\circ}\text{C}$ |
| Thermal Resistance from Junction to case | θ_{JC} | 180 | $^{\circ}\text{C}/\text{W}$ |
| Thermal Resistance from Junction to ambient | θ_{JA} | 250 | $^{\circ}\text{C}/\text{W}$ |

Note: θ_{JA} is measured with the PCB copper area of approximately 1 in²(Multi-layer). That need connect to GND pin.

❖ ELECTRICAL CHARACTERISTICS $T_A=25^{\circ}\text{C}$ (unless otherwise noted)

| Characteristics | Symbol | Conditions | Min | Typ | Max | Units | |
|--|-------------------|--|------------------------|-----------|------|-------------------------|----|
| Input Voltage | V_{IN} | (Note1) | 2.5 | - | 6 | V | |
| Output Voltage Accuracy | ΔV_{OUT} | $I_{OUT}=1\text{mA}, V_{IN}=5\text{V}, V_{OUT} > 2.0\text{V}$ | -2 | - | +2 | % | |
| | | $I_{OUT}=1\text{mA}, V_{IN}=5\text{V}, V_{OUT} \leq 2.0\text{V}$ | -0.04 | - | 0.04 | V | |
| Quiescent Current (Per channel) | I_{CC} | $I_{OUT1,2}=0\text{mA}, V_{IN}=5\text{V}$ | - | 60 | - | μA | |
| Dropout Voltage | V_{DROP} | $I_{OUT}=200\text{mA}, V_o=V_o-2\%$ | $V_{OUT}=1.50\text{V}$ | - | 1000 | 1200 | mV |
| | | | $V_{OUT}=1.80\text{V}$ | - | 700 | 900 | |
| | | | $V_{OUT}>2.50\text{V}$ | - | 300 | 400 | |
| Current Limit (Note 2) | I_{LIMIT} | $V_{IN}=V_{OUT(T)}+1.0\text{V}, V_{EN}=V_{IN}$ | 250 | - | - | mA | |
| Short Circuit Current | I_{short} | $V_{OUT}<1.0\text{V}$, each channel | - | 150 | - | mA | |
| Line Regulation | ΔV_{LINE} | $I_{OUT} = 1\text{mA}, V_{IN}=V_{OUT}+1\text{V}$ to 6.0V | - | 0.2 | 0.3 | %/V | |
| Load Regulation (Note 3) | ΔV_{LOAD} | $I_{OUT}=1\sim 100\text{mA}, V_{IN}=V_{OUT}+1\text{V}$ | - | 0.01 | 0.03 | %/mA | |
| Ripple Rejection | PSRR | $F=120\text{Hz}, I_{OUT} = 30\text{mA}$ | - | 60 | - | dB | |
| Output Voltage Temperature Coefficient | | $I_{OUT}=30\text{mA}$ (Note 4) | - | ± 100 | - | PPM/ $^{\circ}\text{C}$ | |
| Enable Input Threshold | V_{ENH} | | 2.0 | - | - | V | |
| | V_{ENL} | | - | - | 0.8 | | |
| Shutdown Current | I_{SD} | $I_{OUT1,2}=0\text{mA}, V_{IN}=5\text{V}, V_{EN1,2}=0\text{V}$ | - | 1 | 2 | μA | |
| Thermal Shutdown Temperature | T_{ST} | | - | 150 | - | $^{\circ}\text{C}$ | |
| Thermal Shutdown Hysterisis | T_{SH} | | - | 40 | - | $^{\circ}\text{C}$ | |

Note 1: $V_{IN(min)} = V_{OUT} + V_{DROP}$

Note 2: Current limit is measured at constant junction temperature by using pulsed testing with a low ON time.

Note 3: Regulation is measured at constant junction temperature by using pulsed testing with a low ON time.

Note 4: Guaranteed by design.

❖ APPLICATION CIRCUIT

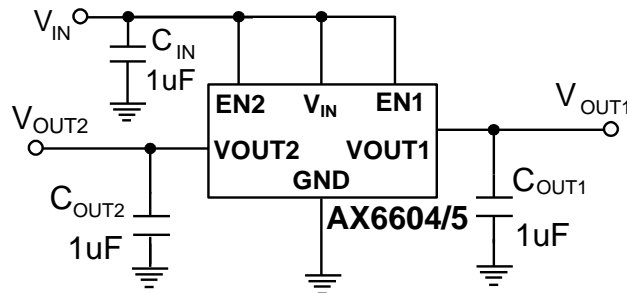

❖ FUNCTION DESCRIPTIONS

The AX6604/5 is a highly accurate, dual, low noise, CMOS LDO voltage regulators with enable function. The output voltage for each regulator is set independently by fuse trimming. As illustrated in function block diagram, it consists of a reference, error amplifier, a P-channel pass transistor, an ON/OFF control logic and an internal feedback voltage divider. The band gap reference is connected to the error amplifier, which compares the reference with the feedback voltage and amplifies the voltage difference. If the feedback voltage is lower than the reference voltage, the pass-transistor gate is pulled lower, which allows more current to pass to the VOUT pin and increases the output voltage. If the feedback voltage is too high, the pass transistor gate is pulled up to decrease the output voltage. The output voltage is feed back through an internal resistive divider connected to VOUT pin. Additional blocks include an output current limiter, thermal sensor, and shutdown logic.

Enable Function

EN1 and EN2 pin start and stop the corresponding outputs independently. When the EN pin is switched to the power off level, the operation of all internal circuit stops, the build-in P-channel MOSFET output transistor between pins VIN and VOUT is switched off, allowing current consumption to be drastically reduced.

Dropout Voltage

A regulator's minimum input-output voltage differential, or dropout voltage, determines the lowest usable supply voltage. The AX6604/5 use a P- channel MOSFET pass transistor, its dropout voltage is function of drain-to-source on-resistance $R_{DS(ON)}$ multiplied by the load current.

$$V_{DROPOUT} = V_{IN} - V_{OUT} = R_{DS(ON)} * I_{OUT}$$

Current Limit

Each channel of AX6604/5 includes a fold back current limiter. It monitors and controls the pass transistor's gate voltage, estimates the output current, and limits the output current within 250mA.

Thermal Shutdown Protection

Thermal Shutdown protection limits total power dissipation of AX6604/5. When the junction temperature exceeds $T_J = +150^{\circ}\text{C}$, a thermal sensor turns off the pass transistor, allowing the IC to cool down. The thermal sensor turns the pass transistor on again after the junction temperature cools down by 40°C , resulting in a pulsed output during continuous thermal shutdown conditions.

Thermal shutdown protection is designed to protect the AX6604/5 in the event of fault conditions. For continuous operation, the absolute maximum operating junction temperature rating of $T_J = +125^{\circ}\text{C}$ should not be exceeded.

❖ APPLICATION INFORMARION

Like any low-dropout regulator, the AX6604/5 requires input and output decoupling capacitors. The device is specifically designed for portable applications requiring minimum board space and smallest components. These capacitors must be correctly selected for good performance (see Capacitor Characteristics Section). Please note that linear regulators with a low dropout voltage have high internal loop gains which require care in guarding against oscillation caused by insufficient decoupling capacitance.

Input Capacitor

An input capacitance of $1\mu\text{F}$ is required between input pin and ground directly (the amount of the capacitance may be increased without limit). The input capacitor must be located less than 1cm from the device to assure input stability. A lower ESR capacitor allows the use of less capacitance, while higher ESR type (like aluminum electrolytic) requires more capacitance. Capacitor types (aluminum, ceramic and tantalum) can be mixed in parallel, but the total equivalent input capacitance/ ESR must be defined as above to stable operation. There are no requirements for the ESR on the input capacitor, but tolerance and temperature coefficient must be considered when selecting the capacitor to ensure the capacitance will be $1\mu\text{F}$ over the entire operating temperature range.

Output Capacitor

The AX6604/5 is designed specifically to work with very small ceramic output capacitors. A ceramic capacitor (temperature characteristics X7R, X5R) in $1\mu\text{F}$ is suitable for the AX6604/5 application. The recommended minimum capacitance for the device is $1\mu\text{F}$, X5R or X7R dielectric ceramic, between VOUT and GND for stability, but it may be increased without limit. Higher capacitance values help to improve transient. The output capacitor's ESR is critical because it forms a zero to provide phase lead which is required for loop stability.

Thermal Considerations

The AX6604/5 series can deliver a current of up to 200mA/channel over the full operating junction temperature range. However, the maximum output current must be debated at higher ambient temperature to ensure the junction temperature does not exceed 125°C. With all possible conditions, the junction temperature must be within the range specified under operating conditions. Power dissipation can be calculated based on the output current and the voltage drop across regulator.

$$P_D = (V_{IN} - V_{OUT}) I_{OUT} + V_{IN} I_{GND}$$

The final operating junction temperature for any set of conditions can be estimated by the following thermal equation:

$$P_{D (MAX)} = (T_{J (MAX)} - T_A) / \theta_{JA}$$

Where $T_{J (MAX)}$ is the maximum junction temperature of the die (125°C) and T_A is the maximum ambient temperature. The junction to ambient thermal resistance (θ_{JA}) SOT-23-6L package at recommended minimum footprint is 250°C/W. Visit our website in which "Recommended Footprints for Soldering Surface Mount Package" for detail.

❖ TYPICAL CHARACTERISTICS

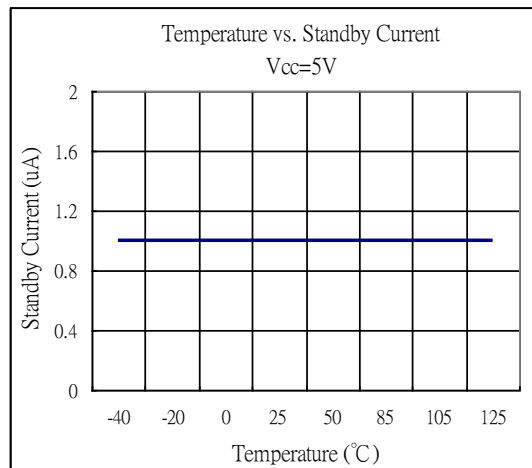
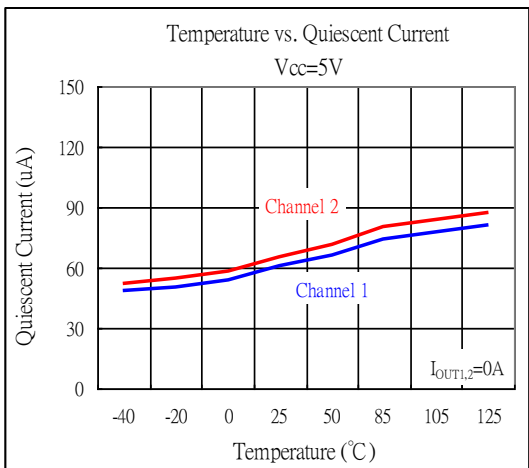
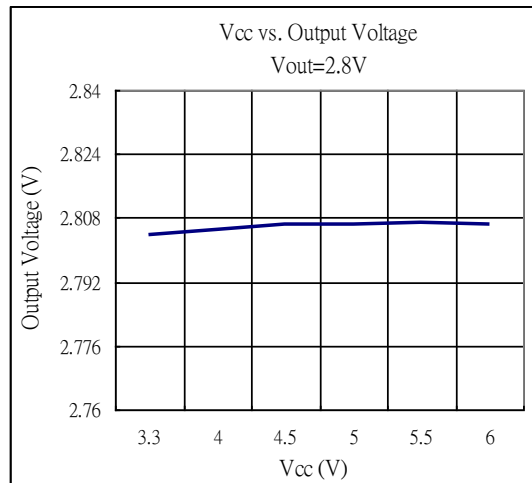
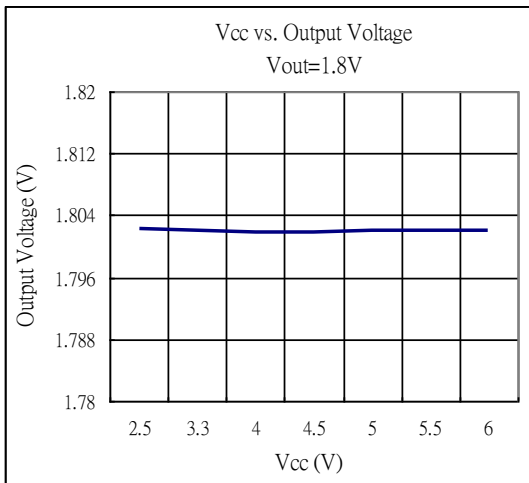
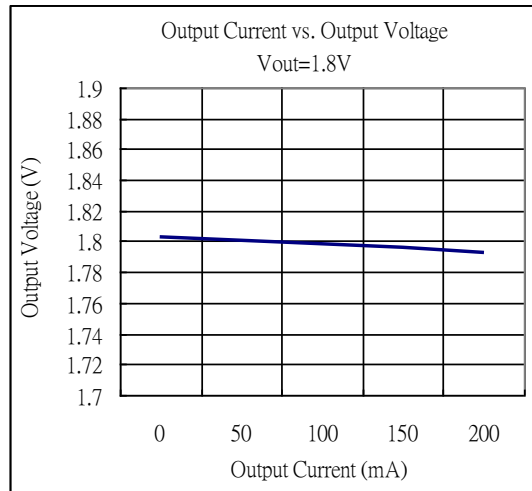
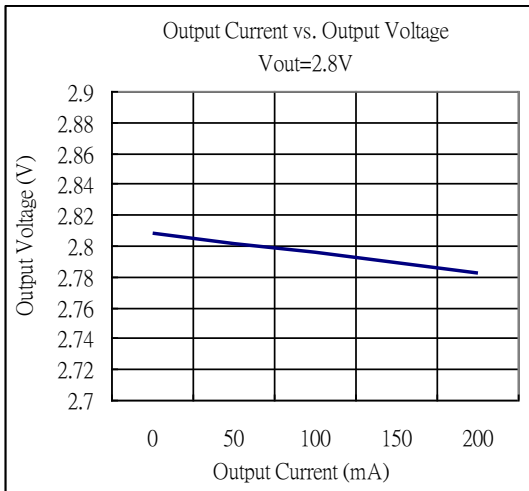

❖ TYPICAL CHARACTERISTICS (CONTINUES)

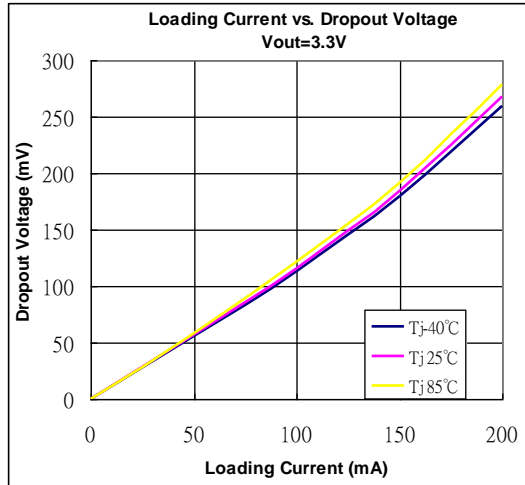
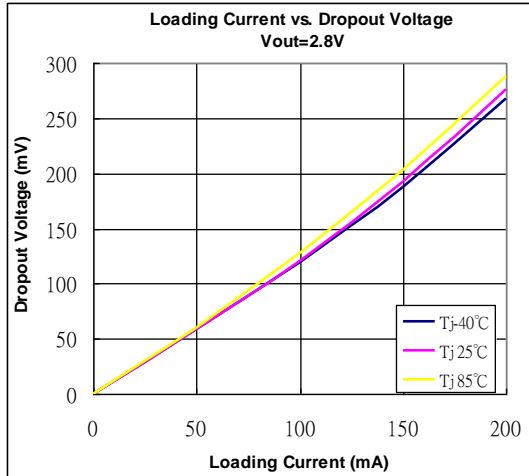
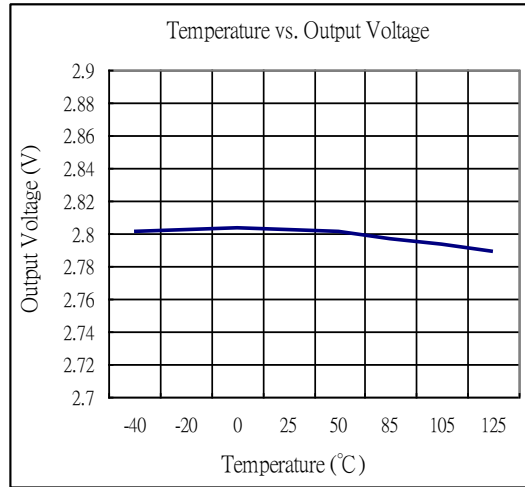
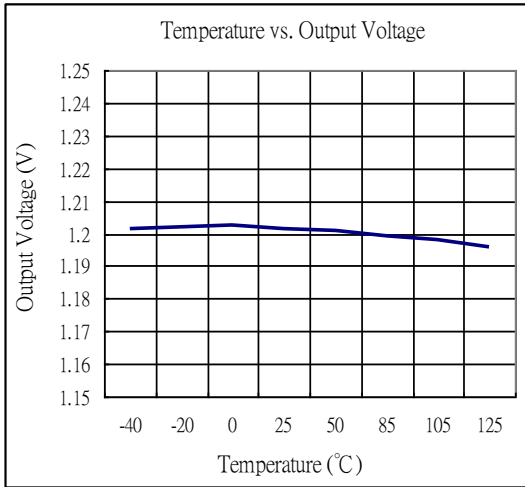

❖ TYPICAL CHARACTERISTICS (CONTINUES)

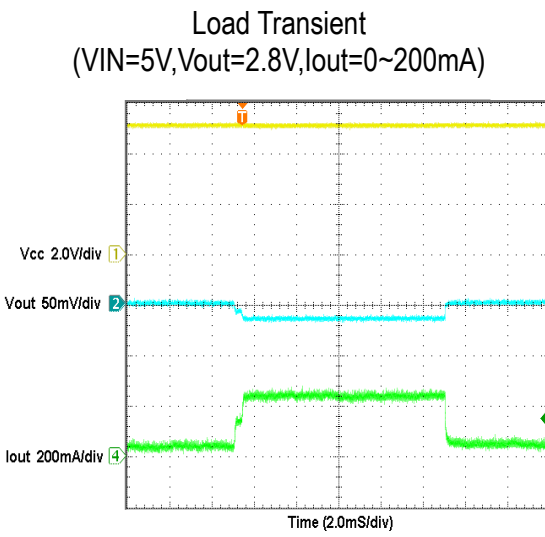
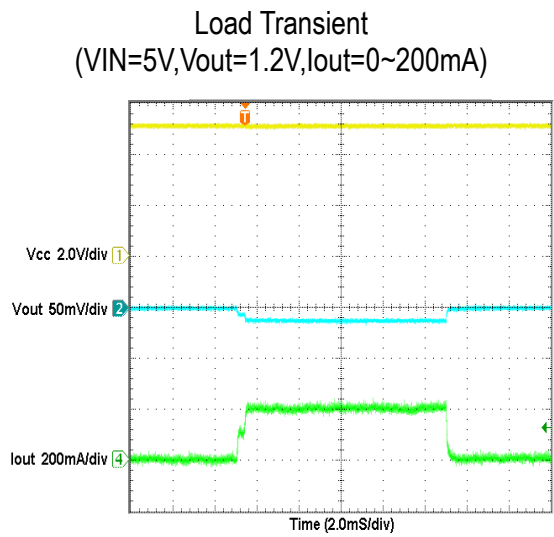
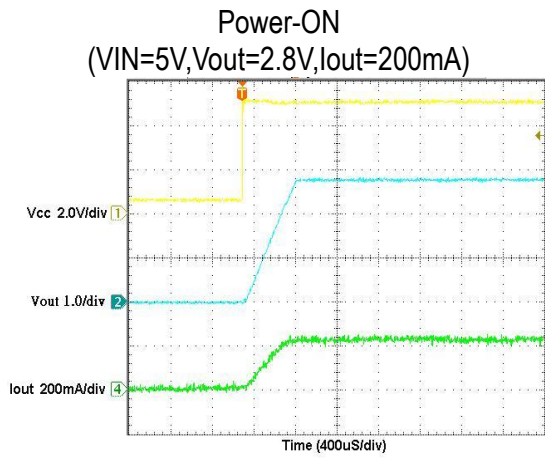
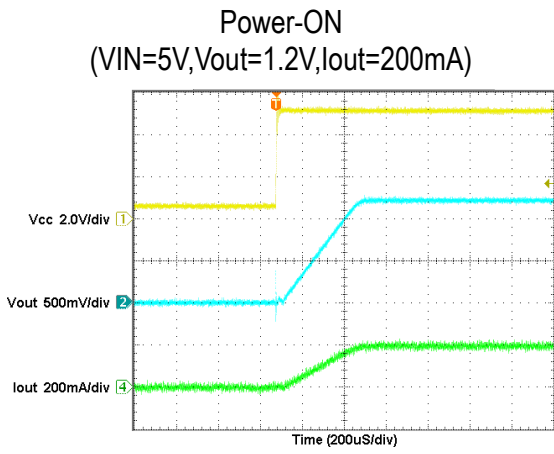

❖ PACKAGE OUTLINES

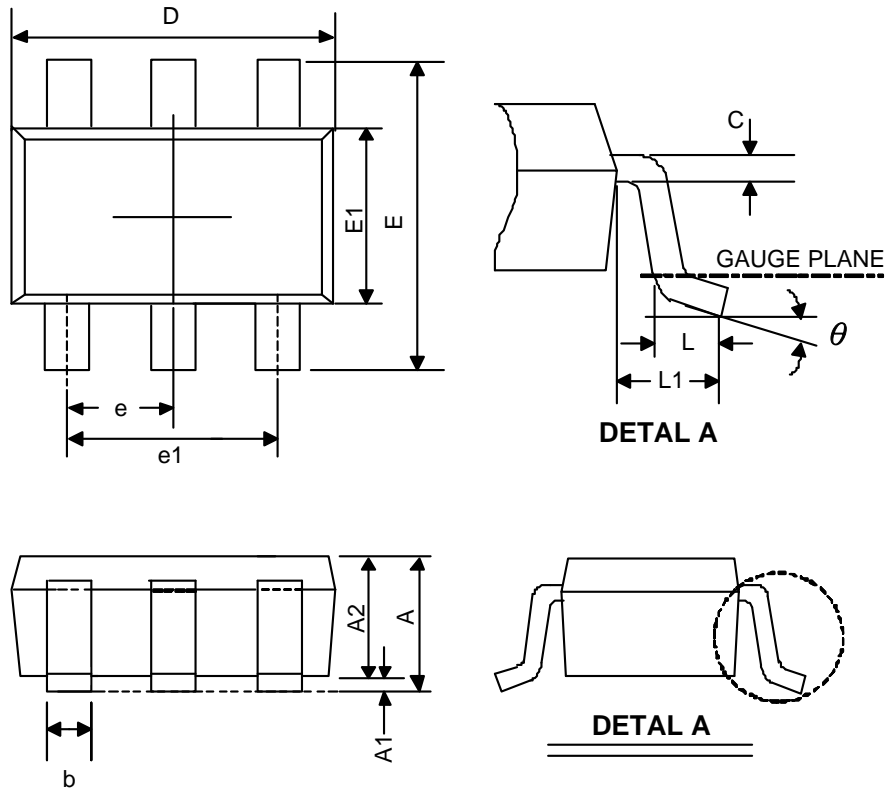

| Symbol | Dimensions in Millimeters | | | Dimensions in Inches | | |
|--------|---------------------------|------|------|----------------------|-------|-------|
| | Min. | Nom. | Max. | Min. | Nom. | Max. |
| A | - | - | 1.45 | - | - | 0.057 |
| A1 | 0 | - | 0.15 | 0 | 0.003 | 0.006 |
| A2 | 0.9 | 1.1 | 1.3 | 0.035 | 0.043 | 0.051 |
| b | 0.3 | 0.4 | 0.5 | 0.012 | 0.016 | 0.02 |
| C | 0.08 | - | 0.22 | 0.003 | 0.006 | 0.009 |
| D | 2.7 | 2.9 | 3.1 | 0.106 | 0.114 | 0.122 |
| E1 | 1.4 | 1.6 | 1.8 | 0.055 | 0.063 | 0.071 |
| E | 2.6 | 2.8 | 3 | 0.102 | 0.11 | 0.118 |
| L | 0.3 | 0.45 | 0.6 | 0.012 | 0.018 | 0.024 |
| L1 | 0.5 | 0.6 | 0.7 | 0.02 | 0.024 | 0.028 |
| e1 | 1.9 BSC | | | 0.075 BSC | | |
| e | 0.95 BSC | | | 0.037 BSC | | |
| θ | 0° | 4° | 8° | 0° | 4° | 8° |

JEDEC outline: MO-178 AB