

350mA Low Dropout Linear Regulator

❖ GENERAL DESCRIPTION

AX1110 is a low dropout positive adjustable or fixed-mode regulator with minimum of 350mA output current capability. The product is specifically designed to provide well-regulated supply for low voltage IC applications such as high-speed bus termination and low current 3.3V logic supply. AX1110 is also well suited for other applications such as VGA cards. AX1110 is guaranteed to have lower than 1.2V dropout at full load current making it ideal to provide well-regulated outputs of 1.25 to 5.0 with 6.4V to 12V input supply.

❖ FEATURES

- 1.2V maximum dropout at full load current
- Fast transient response
- Output Current Limiting
- Built-in Thermal Shutdown
- Good noise rejection
- 3-Terminal Adjustable or Fixed 1.5V, 1.8V, 2.5V, 3.3V, 5.0V
- Packages: SOT-23-3L
- RoHS and Halogen free compliance

❖ BLOCK DIAGRAM

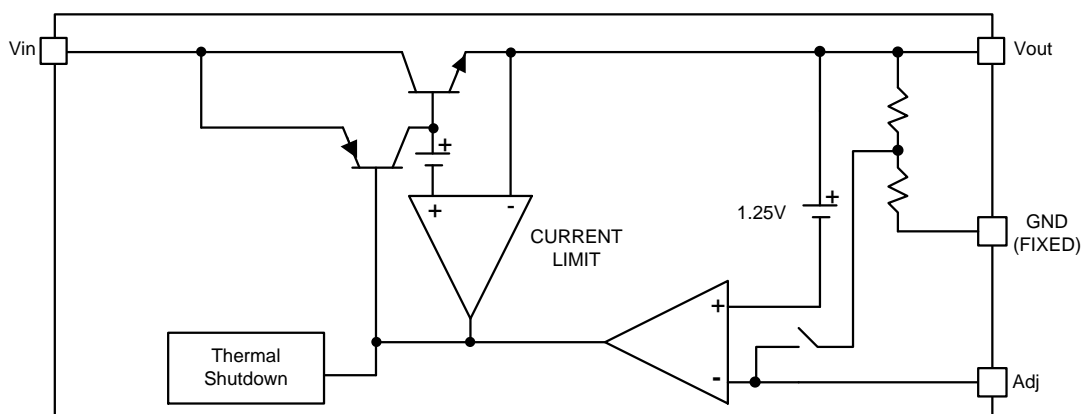

❖ **PIN ASSIGNMENT**

The package of AX1110 is SOT-23-3L; the pin assignment is given by:

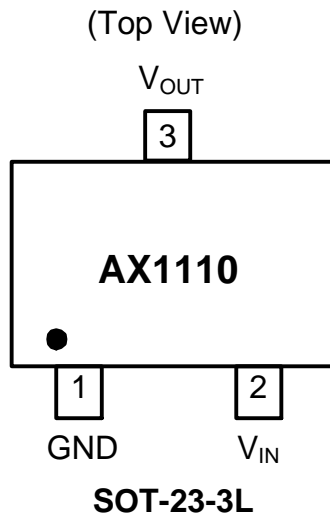

Name	Description
Adj (GND)	A resistor divider from this pin to the V _{OUT} pin and ground sets the output voltage. (Ground only for Fixed-Mode)
V _{IN}	The input pin of regulator. Typically a large storage capacitor (0.15Ω ≤ ESR ≤ 20Ω) is connected from this pin to ground to insure that the input voltage does not sag below the minimum dropout voltage during the load transient response. This pin must always be 1.4V higher than V _{OUT} in order for the device to regulate properly.
V _{OUT}	The output of the regulator. A minimum of 10uF capacitor (0.15Ω ≤ ESR ≤ 20Ω) must be connected from this pin to ground to insure stability.

❖ **ORDER/MARKING INFORMATION**

Order Information	Top Marking
<p>AX 1110 X XX X</p> <p>Low Dropout Regulator Package R : SOT-23-3L Vout Blank : ADJ 15 : 1.5V 18 : 1.8V 25 : 2.5V 33 : 3.3V 50 : 5.0V Packing Blank : Bag A : Taping</p>	<p>Output Type: ← L L Y W X → ID Code: internal</p> <p>DA : ADJ WW : 01~26(A~Z) 27~52(a~z)</p> <p>D1 : 1.5V</p> <p>D2 : 1.8V</p> <p>D3 : 2.5V</p> <p>D4 : 3.3V</p> <p>D5 : 5.0V</p> <p>Year: 8=2018 9=2019 B=2020 C=2021 D=2022 : Z=2044</p>

❖ **ABSOLUTE MAXIMUM RATINGS**

Characteristics	Symbol	Rating	Unit
DC Supply Voltage	V _{IN}	-0.3 to 15	V
Operating Junction Temperature Range	T _{OP}	-40 to +125	°C
Maximum junction Temperature	T _{MJ}	150	°C
Power Dissipation (multi-layer PCB copper area 2mm*2mm) T _A =25°C, T _J =125°C, SOT-23	P _D	450	mW
Storage Temperature	T _{ST}	-65 to +150	°C

❖ ELECTRICAL CHARACTERISTICS

(Under Operating Conditions)

Characteristics	Conditions		Min	Typ	Max	Units
Operation Input Voltage	$I_{OUT}=350\text{mA}$		-	-	12	V
Reference Voltage	AX1110-ADJ	$T_J=25^\circ\text{C}$, $(V_{IN-OUT})=1.5\text{V}$ $I_{OUT}=10\text{mA}$	1.225	1.250	1.275	V
Output Voltage	AX1110-1.5	$I_{OUT}=10\text{mA}$, $T_J=25^\circ\text{C}$, $3\text{V} \leq V_{IN} \leq 12\text{V}$	1.470	1.500	1.530	V
	AX1110-1.8	$I_{OUT}=10\text{mA}$, $T_J=25^\circ\text{C}$, $3.3\text{V} \leq V_{IN} \leq 12\text{V}$	1.764	1.800	1.836	V
	AX1110-2.5	$I_{OUT}=10\text{mA}$, $T_J=25^\circ\text{C}$, $4\text{V} \leq V_{IN} \leq 12\text{V}$	2.450	2.500	2.550	V
	AX1110-3.3	$I_{OUT}=10\text{mA}$, $T_J=25^\circ\text{C}$, $4.8\text{V} \leq V_{IN} \leq 12\text{V}$	3.235	3.300	3.365	V
	AX1110-5.0	$I_{OUT}=10\text{mA}$, $T_J=25^\circ\text{C}$, $6.5\text{V} \leq V_{IN} \leq 12\text{V}$	4.900	5.000	5.100	V
Line Regulation	AX1110-XXX	$I_{OUT}=10\text{mA}$, $V_{OUT}+1.5\text{V} < V_{IN} < 12\text{V}$, $T_J=25^\circ\text{C}$ (Note 1,2)	-	0.1	0.5	%
Load Regulation	AX1110-ADJ	$V_{IN}=3\text{V}$, $V_{adj}=0.0\text{mA} < I_{OUT} < 350\text{mA}$, $T_J=25^\circ\text{C}$ (Note 1,2)	-	-	1	%
	AX1110-1.5	$V_{IN}=3\text{V}$, $0\text{mA} < I_{OUT} < 350\text{mA}$, $T_J=25^\circ\text{C}$ (Note 1,2)	-	12	15	mV
	AX1110-1.8	$V_{IN}=3.3\text{V}$, $0\text{mA} < I_{OUT} < 350\text{mA}$, $T_J=25^\circ\text{C}$ (Note 1,2)	-	15	18	mV
	AX1110-2.5	$V_{IN}=4\text{V}$, $0\text{mA} < I_{OUT} < 350\text{mA}$, $T_J=25^\circ\text{C}$ (Note 1,2)	-	20	25	mV
	AX1110-3.3	$V_{IN}=5\text{V}$, $0 \leq I_{OUT} \leq 350\text{mA}$, $T_J=25^\circ\text{C}$ (Note 1,2)	-	26	33	mV
	AX1110-5.0	$V_{IN}=6.5\text{V}$, $0 \leq I_{OUT} \leq 350\text{mA}$, $T_J=25^\circ\text{C}$ (Note 1,2)	-	40	50	mV
Dropout Voltage ($V_{IN}-V_{OUT}$)	AX1110-ADJ/1.5/ 1.8/2.5/3.3/5.0	$I_{OUT}=350\text{mA}$, $\Delta V_{OUT}=1\%V_{OUT}$	-	1.1	1.2	V
Current Limit	AX1110-ADJ/1.5/ 1.8/2.5/3.3/5.0	$(V_{IN}-V_{OUT})=2\text{V}$	0.5	-	-	A
Minimum Load Current	AX1110-XXX	$0^\circ\text{C} \leq T_J \leq 125^\circ\text{C}$	-	5	10	mA
Ripple Rejection	F=120Hz, $C_{OUT}=25\mu\text{F}$ Tantalum, $I_{OUT}=350\text{mA}$					
	AX1110-XXX	$V_{IN}=V_{OUT}+3\text{V}$	-	60	70	dB
Temperature Stability	$I_{OUT}=10\text{mA}$		-	0.5	-	%

❖ ELECTRICAL CHARACTERISTICS (CONTINUED)

θ_{JA} Thermal Resistance Junction-to-Ambient (Note4)	SOT-23	-	220	-	°C/W
θ_{JC} Thermal Resistance Junction-to-Case	SOT-23	-	120	-	°C/W

Note1: See thermal regulation specifications for changes in output voltage due to heating effects. Line and load regulation are measured at a constant junction temperature by low duty cycle pulse testing. Load regulation is measured at the output lead = 1/18" from the package.

Note2: Line and load regulation are guaranteed up to the maximum power dissipation of 5W. Power dissipation is determined by the difference between input and output differential and the output current. Guaranteed maximum power dissipation will not be available over the full input/output range.

Note3: Quiescent current is defined as the minimum output current required in maintaining regulation. At 12V input/output differential the device is guaranteed to regulate if the output current is greater than 10mA.

Note4: V_{OUT} Pin is connected to the multi-layer PCB copper area 2mm*2mm.

❖ APPLICATION CIRCUIT

Fixed Output

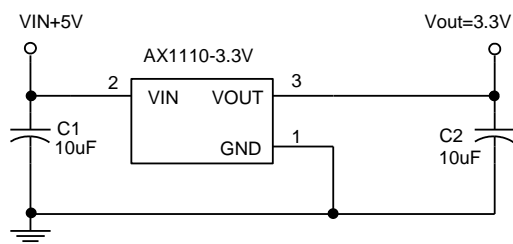

ADJ Output

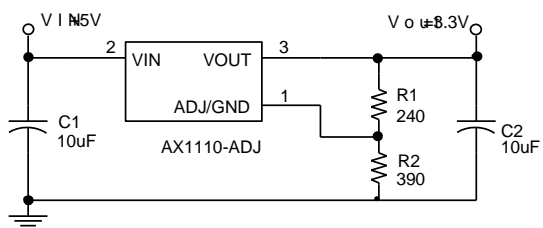

$$V_{OUT} = V_{REF} \times \left(1 + \frac{R_2}{R_1}\right)$$

$$V_{REF} = 1.250V$$

❖ TYPICAL CHARACTERISTICS

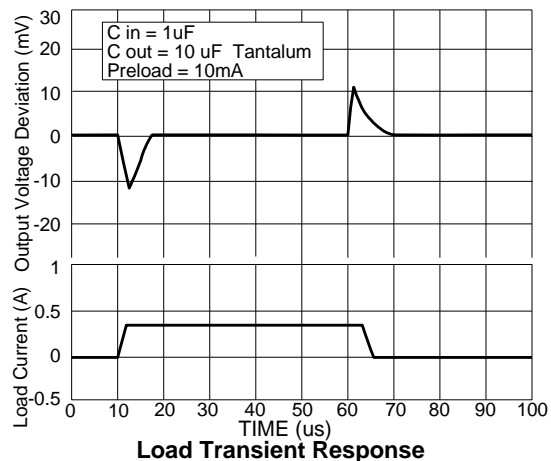
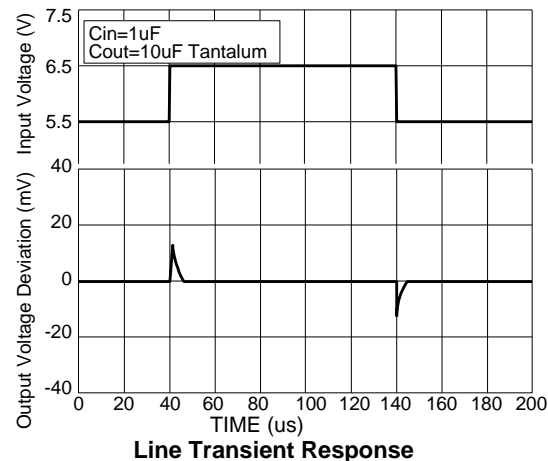
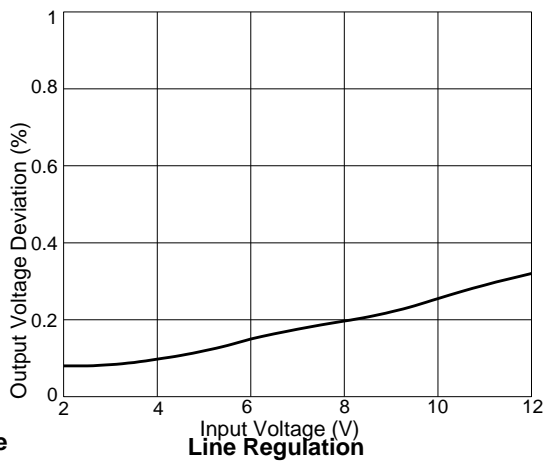
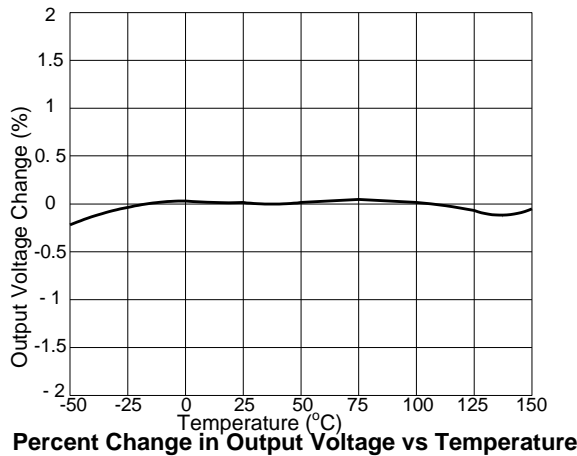
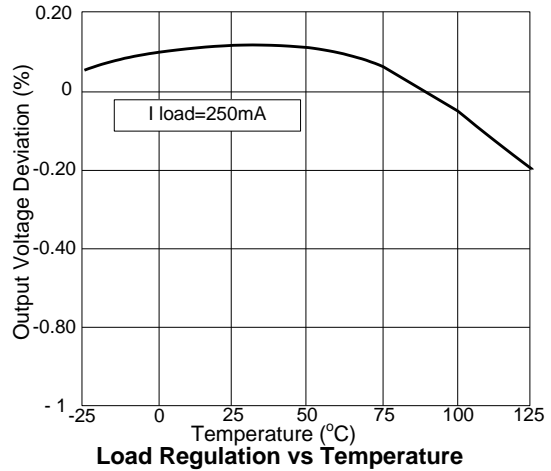
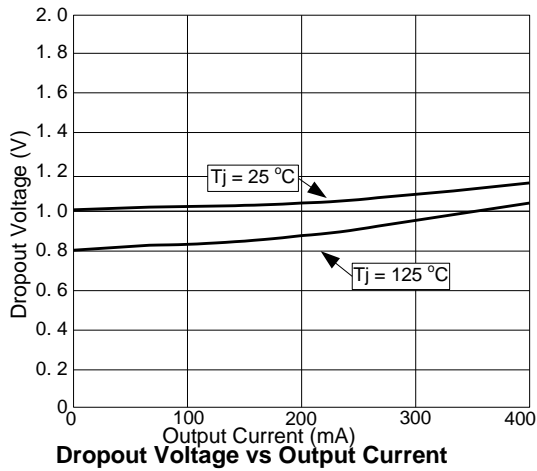

❖ PACKAGE OUTLINES

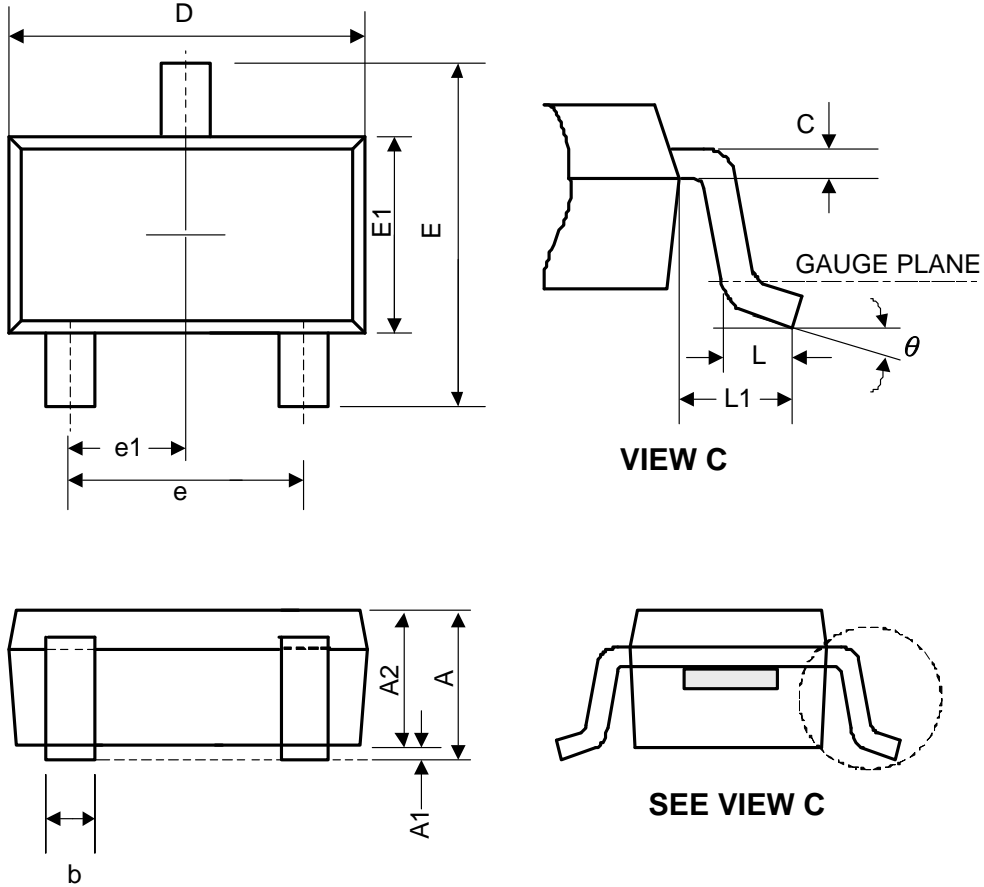

Symbol	Dimensions in Millimeters			Dimensions in Inches		
	Min.	Nom.	Max.	Min.	Nom.	Max.
A	-	-	1.45	-	-	0.057
A1	0	0.08	0.15	-	-	0.006
A2	0.9	1.1	1.3	0.035	0.043	0.051
b	0.3	0.4	0.5	0.012	0.016	0.02
C	0.08	0.15	0.22	0.003	0.006	0.009
D	2.7	2.9	3.1	0.106	0.114	0.122
E	2.6	2.8	3	0.102	0.11	0.118
E1	1.4	1.6	1.8	0.055	0.063	0.071
L	0.3	0.45	0.6	0.012	0.018	0.024
L1	0.5	0.6	0.7	0.02	0.024	0.028
e	1.9 BSC			0.075 BSC		
e1	0.95 BSC			0.037 BSC		
θ	0°	4°	8°	0°	4°	8°

JEDEC outline: NA

❖ Carrier tape dimension

SOT23-3L

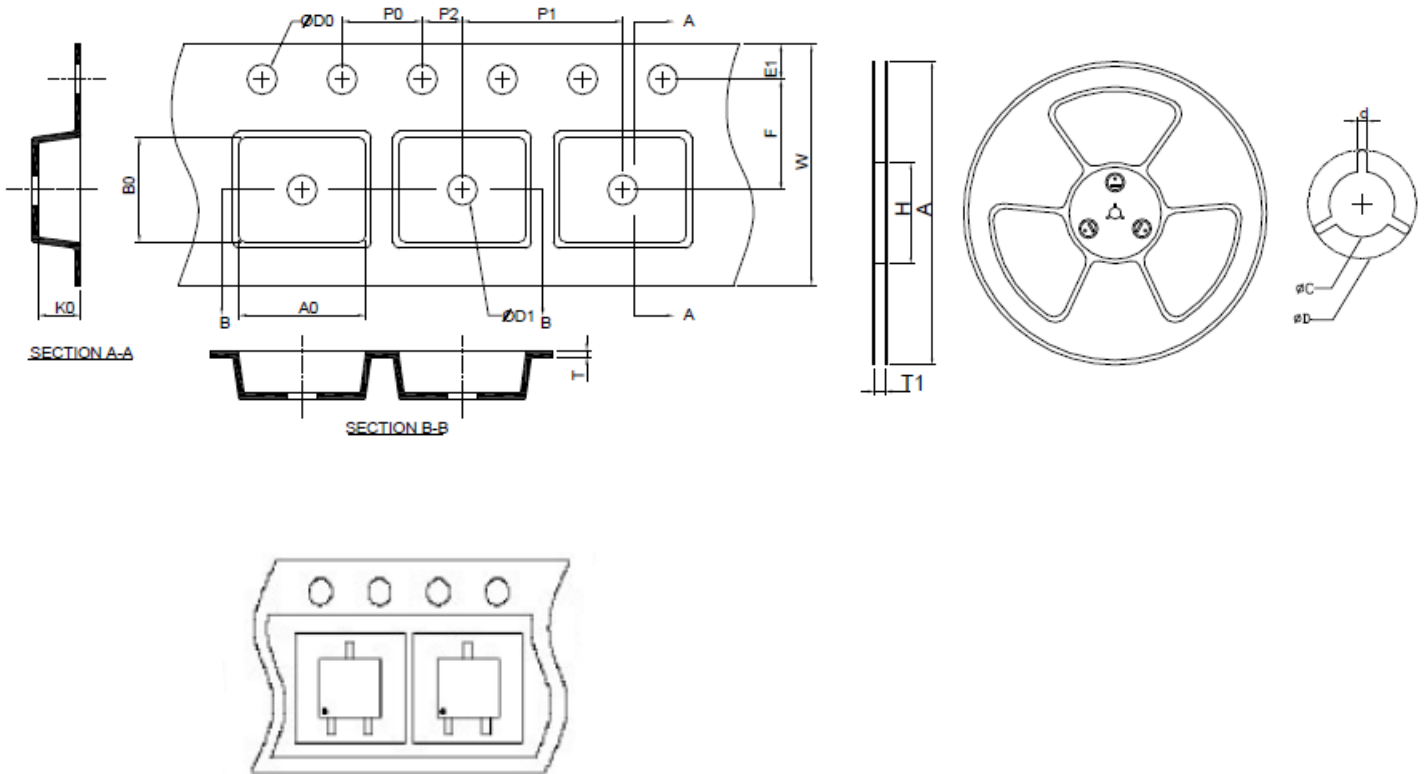

A	H	T1	C	d	D	W	E1	F
178.0±2.00	50 MIN.	8.4+2.00 -0.00	13.0+0.50 -0.20	1.5 MIN.	20.2 MIN.	8.0±0.30	1.75±0.10	3.5±0.05
P0	P1	P2	D0	D1	T	A0	B0	K0
4.0±0.10	4.0±0.10	2.0±0.05	1.5+0.10 -0.00	1.0 MIN.	0.6+0.00 -0.40	3.20±0.20	3.10±0.20	1.50±0.20

(mm)