

## **1.5MHz, 1A Synchronous Step-Down Converter**

### **❖ GENERAL DESCRIPTION**

AX3503 is a high efficiency monolithic synchronous buck regulator using a constant frequency, current mode architecture. The device is available in an adjustable version. Supply current with no load is 35uA and drops to <1uA in shutdown. The 2.5V to 6V input voltage range makes AX3503 ideally suited for single Li-Ion, two to four AA battery-powered applications. 100% duty cycle provides low dropout operation, extending battery life in portable systems. PWM pulse skipping mode operation provides very low output ripple voltage for noise sensitive applications. Switching frequency is internally set at 1.5MHz, allowing the use of small surface mount inductors and capacitors. The internal synchronous switch increases efficiency and decreases need of an external Schottky diode. Low output voltages are easily supported with the 0.6V feedback reference voltage. AX3503 is available in small SOT-23-5L and TDFN-6L (2\*2) packages.

### **❖ FEATURES**

- 2.5V to 6V Input Voltage Range
- High Efficiency: Up to 94%
- 1.5MHz Constant Frequency Operation
- 1A Output Current at  $V_{IN}=3.6V$  and  $V_{OUT}=1.8V$
- Quiescent Current: 35uA (input < 4.2V)
- No Schottky Diode Required
- 100% Duty Cycle in Dropout
- 0.6V Reference Allows Low Output Voltages
- Current Mode Operation for Excellent Line and Load Transient Response
- Current limit, Enable function
- Short Circuit Protect (SCP)
- $\leq 1\mu A$  Shutdown Current
- SOT-23-5L and TDFN-6L (2\*2) Pb-Free packages
- RoHS and Halogen free compliance.

❖ **BLOCK DIAGRAM**

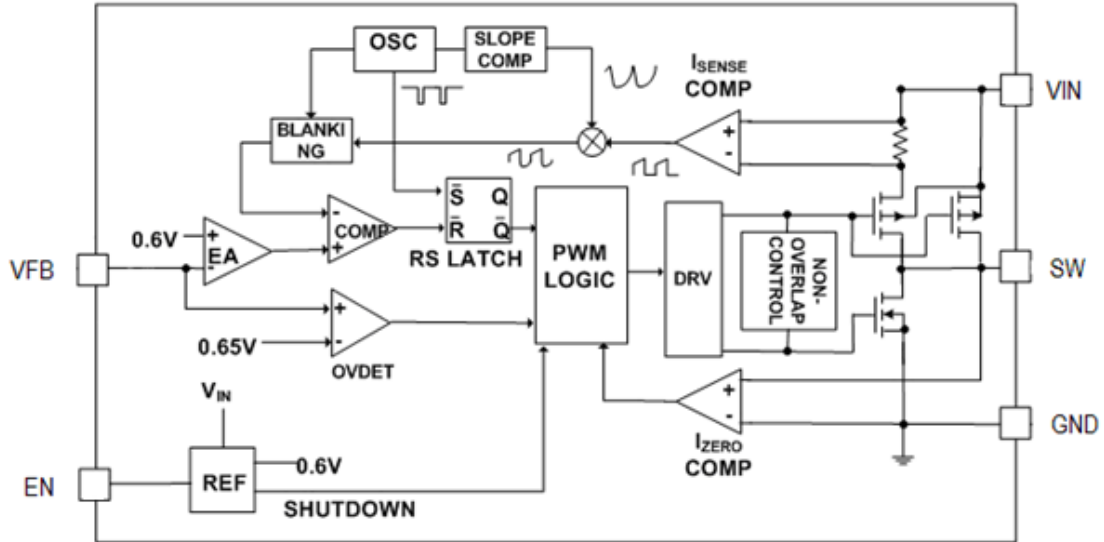

❖ **PIN ASSIGNMENT**

The packages of AX3503 are SOT-23-5L and TDFN-6L (2\*2); the pin assignment is given by:

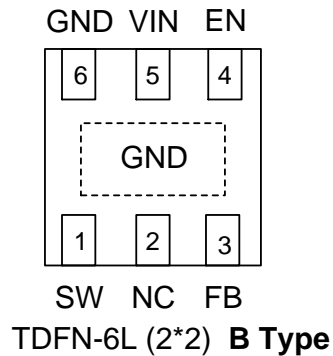
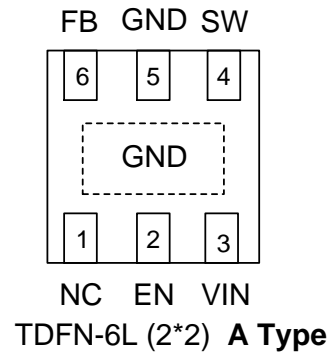
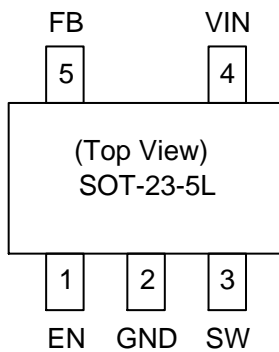

Name	Description
EN	Enable pin H : normal operation L : Shutdown
VIN	Power Supply Input Pin
SW	Switch output pin. Connect external inductor here. Minimize trace area at this pin to reduce EMI.
GND	Ground Pin
FB	Output Feedback pin



❖ **ELECTRICAL CHARACTERISTICS**

( $V_{IN} = V_{EN}=3.6V$ ,  $T_A = 25^{\circ}C$ , unless otherwise specified) (Note)

Characteristics	Symbol	Conditions	Min	Typ	Max	Units
Input Voltage Range	$V_{IN}$		2.5	-	6	V
Feedback Voltage	$V_{FB}$	$T_A = +25^{\circ}C$	0.588	0.600	0.612	V
		$T_A = 0^{\circ}C \leq T_A \leq 85^{\circ}C$	0.587	0.600	0.614	
		$T_A = -40^{\circ}C \leq T_A \leq 85^{\circ}C$	0.582	0.600	0.618	
Feedback Bias Current	$I_{FB}$	$V_{FB}=0.65V$	-	-	$\pm 30$	nA
Input DC Supply Current	$I_{CC}$	$V_{FB}=0V$	-	35	45	$\mu A$
Shutdown Supply Current	$I_{SD}$	$V_{EN} = 0V$	-	0.1	1	$\mu A$
Switching Current Limit	$I_{LIMIT}$		1.2	1.4	-	A
Line Regulation	$\Delta V_{OUT}/V_{OUT}$	$V_{IN} = 2.5V \sim 5.5V$	-	0.04	0.4	%/V
Load Regulation	$\Delta V_{OUT}/V_{OUT}$	$I_{OUT} = 0.01$ to 1A	-	1	-	%
Oscillation Frequency	$F_{OSC}$	SW pin, $V_{IN}=3.6V$ to $V_{OUT} = 1.2V$	1.2	1.5	2.0	MHz
$R_{DS(ON)}$ of P-CH MOSFET	$R_{DSON}$	$I_{SW} = 300mA$	-	0.35	0.50	$\Omega$
$R_{DS(ON)}$ of N-CH MOSFET	$R_{DSON}$	$I_{SW} = -300mA$	-	0.30	0.45	$\Omega$
EN pin logic input threshold voltage	$V_{ENL}$		0.6	-	-	V
	$V_{ENH}$		-	-	1.2	
EN Pin Input Current	$I_{EN}$		-	$\pm 0.1$	$\pm 1$	$\mu A$
Efficiency	EFFI	$V_{IN}=5V$ , $V_{OUT}=3.3V$ , $I_{OUT}=0.5A$	-	92	-	%

Note: 100% production test at +25°C. Specifications over the temperature range are guaranteed by design and characterization.

❖ **APPLICATION CIRCUIT**

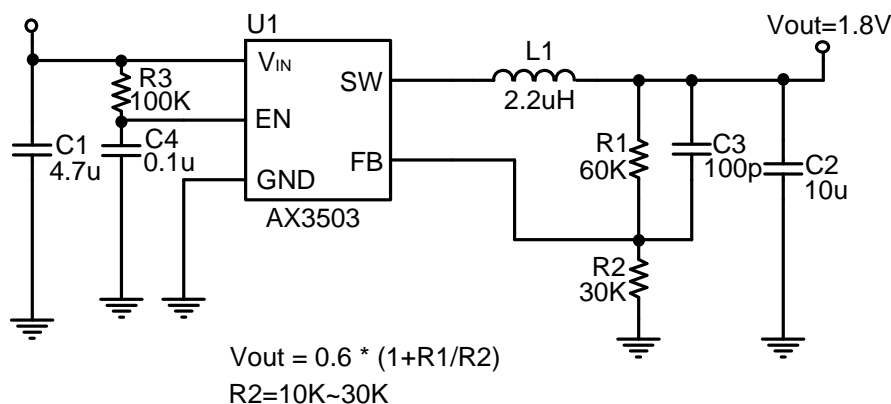

## ❖ FUNCTION DESCRIPTIONS

### Operation

AX3503 is a monolithic switching mode step-down DC-DC converter. It utilizes internal MOSFETs to achieve high efficiency and can generate very low output voltage by using internal reference at 0.6V. It operates at a fixed switching frequency, and uses the slope compensated current mode architecture. This step-down DC-DC Converter supplies 1000mA output current at  $V_{OUT} = 1.8V$  with input voltage range from 2.5V to 6V.

### Current Mode PWM Control

Slope compensated current mode PWM control provides stable switching and cycle-by-cycle current limit for excellent load and line responses and protection of the internal main switch (P-Ch MOSFET) and synchronous rectifier (N-CH MOSFET). During normal operation, the internal P-Ch MOSFET is turned on for a certain time to ramp the inductor current at each rising edge of the internal oscillator, and switched off when the peak inductor current is above the error voltage. The current comparator,  $I_{COMP}$ , limits the peak inductor current. When the main switch is off, the synchronous rectifier will be turned on immediately and stay on until either the inductor current starts to reverse, as indicated by the current reversal comparator,  $I_{ZERO}$ , or the beginning of the next clock cycle. The OVDET comparator controls output transient overshoots by turning the main switch off and keeping it off until the fault is no longer present.

### Idle Mode Operation

At very light loads, AX3503 automatically enters pulse skipping Mode. In the pulse skipping Mode, the inductor current may reach zero or reverse on each pulse. The PWM control loop will automatically skip pulses to maintain output regulation. The bottom MOSFET is turned off by the current reversal comparator,  $I_{ZERO}$ , and the switch voltage will ring. This is discontinuous mode operation, and is normal behavior for the switching regulator.

### Maximum Load Current

AX3503 will operate with input supply voltage as low as 2.5V, however, the maximum load current decreases at lower input due to large IR drop on the main switch and synchronous rectifier. The slope compensation signal reduces the peak inductor current as a function of the duty cycle to prevent sub-harmonic oscillations at duty cycles greater than 50%. Conversely the current limit increases as the duty cycle decreases.

❖ APPLICATION INFORMATION

**Setting the Output Voltage**

Application circuit item shows the basic application circuit with AX3503 adjustable output version. The external resistor sets the output voltage according to the following equation:

$$V_{OUT} = 0.6V \times \left(1 + \frac{R1}{R2}\right)$$

Table 1 Resistor select for output voltage setting

V <sub>OUT</sub>	R2	R1
1.2V	30K	30K
1.5V	30K	45K
1.8V	30K	60K
2.5V	30K	95K

**Inductor Selection**

For most designs, the AX3503 operates with inductors of 1μH to 2.2μH. Low inductance values are physically smaller but require faster switching, which results in some efficiency loss. The inductor value can be derived from the following equation:

$$L = \frac{V_{OUT} \times (V_{IN} - V_{OUT})}{V_{IN} \times \Delta I_L \times f_{OSC}}$$

Where is inductor Ripple Current. Large value inductors lower ripple current and small value inductors result in high ripple currents. Choose inductor ripple current approximately 35% of the maximum load current 1000mA, ΔI<sub>L</sub>=350mA.

Table 2 Inductor select for output voltage setting (V<sub>CC</sub>=3.6V)

V <sub>OUT</sub>	1.2V	1.5V	1.8V	2.5V
Inductor	2.2uH	2.2uH	2.2uH	2.2uH
Part Number WE-TPC	7440430027	7440430027	7440430027	7440430022

Note: Part type MH or M (www.we-online.com)

For output voltages above 2.0V, when light-load efficiency is important, the minimum recommended inductor is 2.2μH. For optimum voltage-positioning load transients, choose an inductor with DC series resistance in the 50mΩ to 150mΩ range. For higher efficiency at heavy loads (above 200mA), or minimal load regulation (but some transient overshoot), the resistance should be kept below 100mΩ. The DC current rating of the inductor should be at least equal to the maximum load current plus half the ripple current to prevent core saturation (1000mA+170mA).

## Input Capacitor Selection

The input capacitor reduces the surge current drawn from the input and switching noise from the device. The input capacitor impedance at the switching frequency shall be less than input source impedance to prevent high frequency switching current passing to the input. A low ESR input capacitor sized for maximum RMS current must be used. Ceramic capacitors with X5R or X7R dielectrics are highly recommended because of their low ESR and small temperature coefficients. A 4.7 $\mu$ F ceramic capacitor for most applications is sufficient.

## Output Capacitor Selection

The output capacitor is required to keep the output voltage ripple small and to ensure regulation loop stability. The output capacitor must have low impedance at the switching frequency. Ceramic capacitors with X5R or X7R dielectrics are recommended due to their low ESR and high ripple current.

## Compensation Capacitor Selection

The compensation capacitors for increasing phase margin provide additional stability. It is required and more than 22p, Refer to Demo Board Schematic, The optimum values for C3 is 100pF.

## Layout Guidance

When laying out the PC board, the following suggestions should be taken to ensure proper operation of the AX3503. These items are also illustrated graphically in below.

1. The power traces, including the GND trace, the SW trace and the  $V_{IN}$  trace should be kept short, direct and wide to allow large current flow. Put enough multiply-layer pads when they need to change the trace layer.
2. Connect the input capacitor C1 to the  $V_{IN}$  pin as closely as possible to get good power filter effect.
3. Keep the switching node, SW, away from the sensitive FB node.
4. Do not trace signal line under inductor.

### TSOT-23-5L Layout Guide

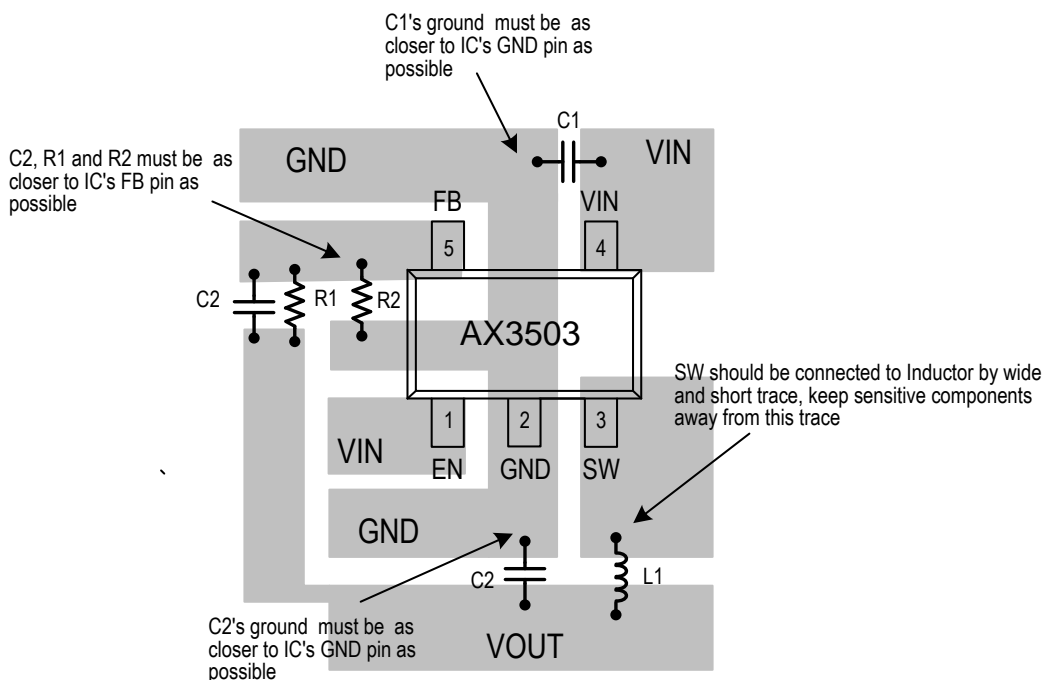

### TDFN-6L Layout Guide

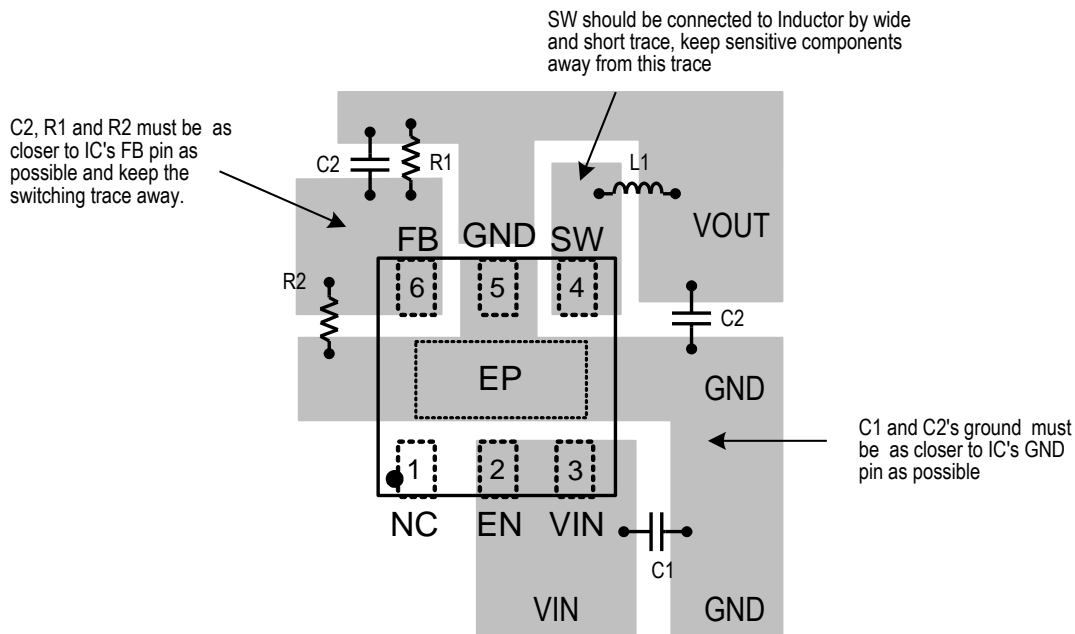



❖ TYPICAL CHARACTERISTICS

Quiescent Current vs. Input Voltage

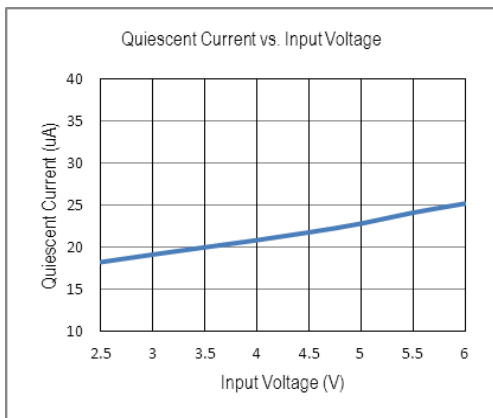

Line Regulation  
 $I_{OUT}=0.01A$

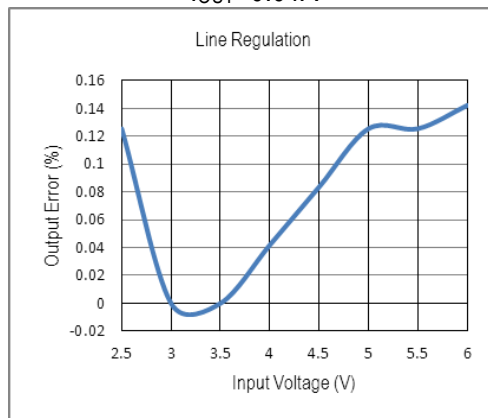

Load Regulation  
 $V_{IN}=3.6V, V_{OUT}=1.2V, L=2.2uH$

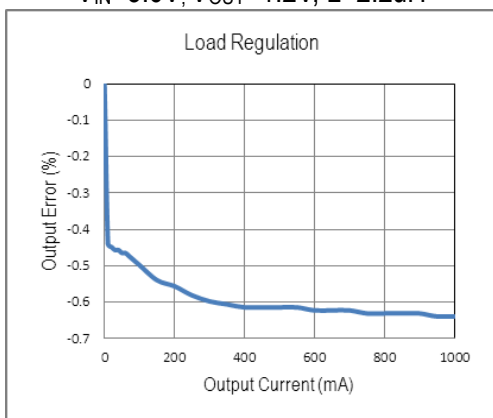

Efficiency vs. Output Current  
 $V_{OUT}=1.2V, L=2.2uH$

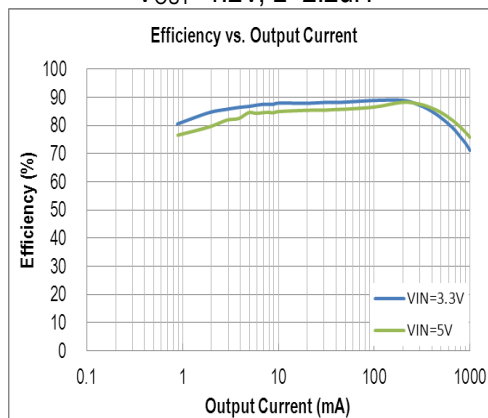

Efficiency vs. Output Current  
 $V_{OUT}=1.8V, L=2.2uH$

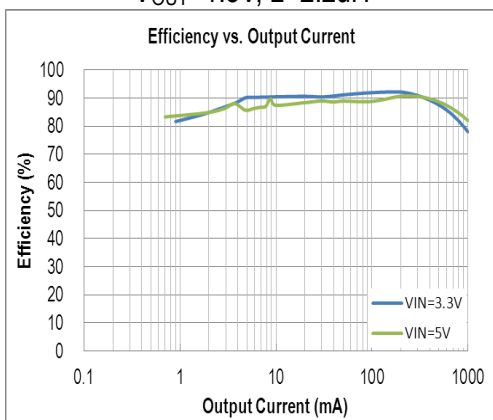

Efficiency vs. Output Current  
 $V_{OUT}=3.3V, L=2.2uH$

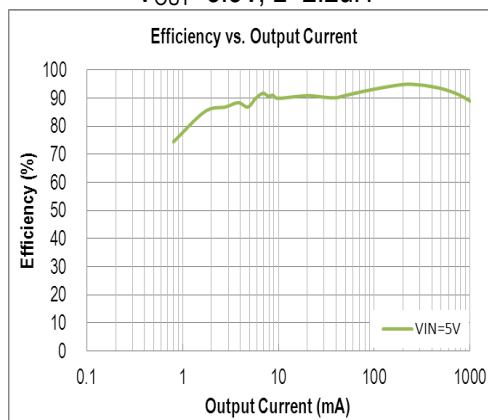

❖ TYPICAL CHARACTERISTICS (CONTINUES)

Frequency vs. Temperature  
 $V_{IN}=3.6V$ ,  $V_{OUT}=1.2V$ ,  $L=2.2\mu H$

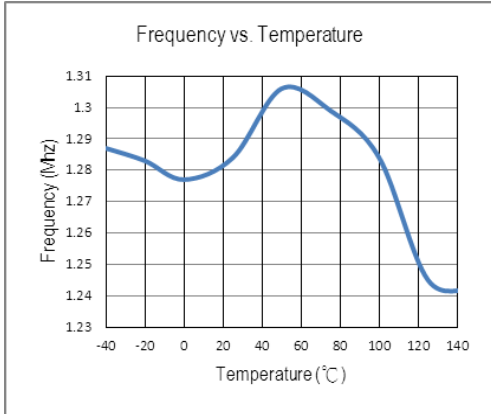

Output Error vs. Temperature  
 $V_{IN}=3.6V$ ,  $V_{OUT}=1.2V$ ,  $L=2.2\mu H$

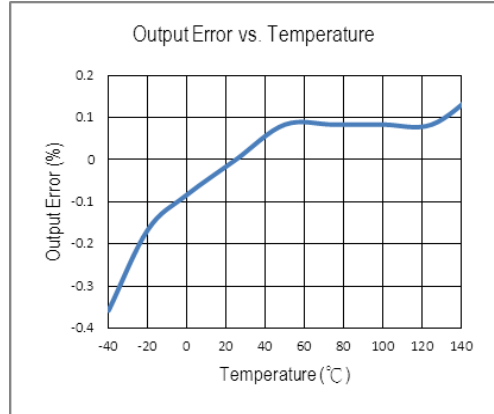

Quiescent Current vs. Temperature  
 $V_{IN}=3.6V$

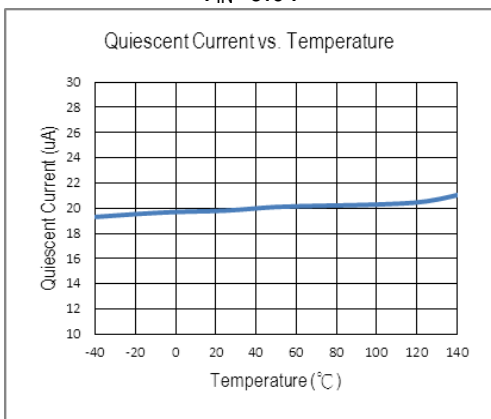

❖ TYPICAL CHARACTERISTICS (CONTINUES)

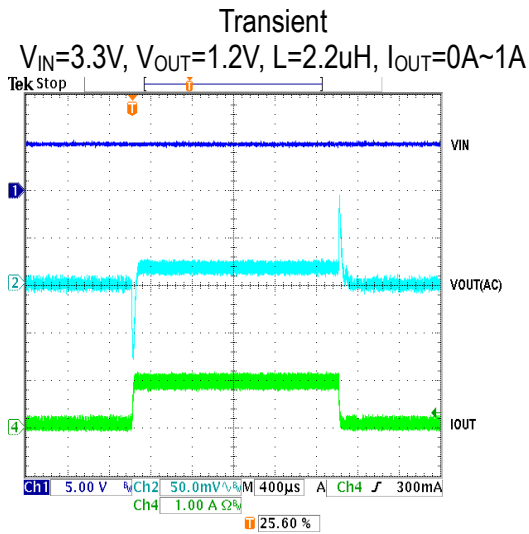
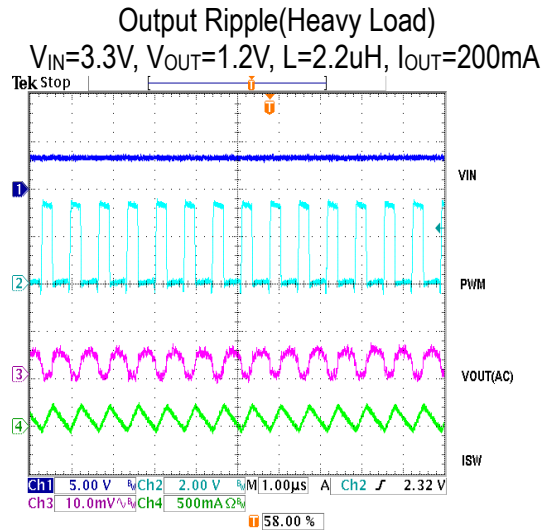
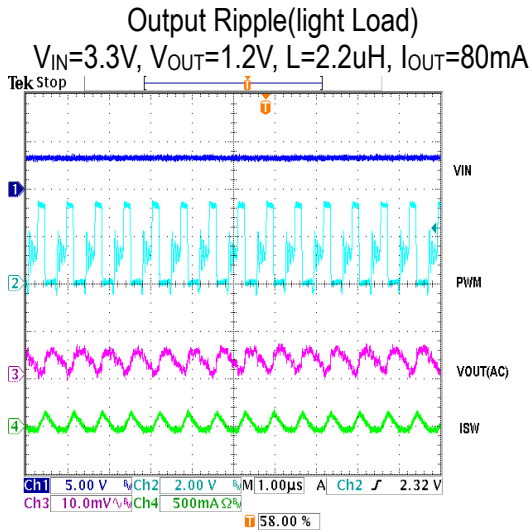

❖ PACKAGE OUTLINES

(1) SOT-23-5L

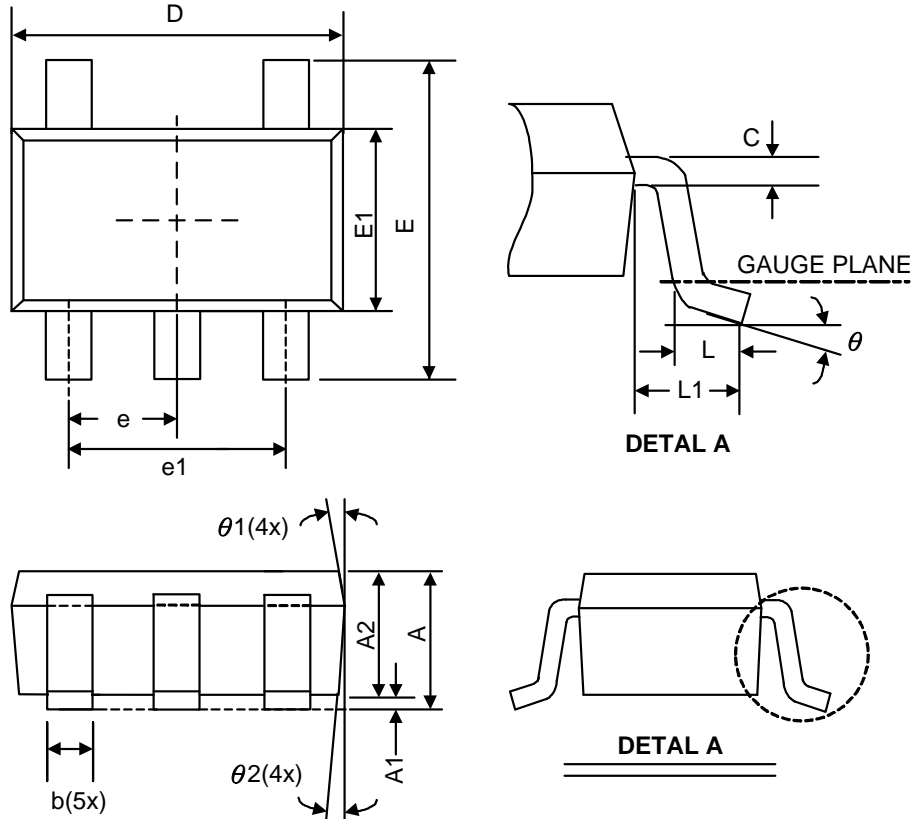

Symbol	Dimensions in Millimeters			Dimensions in Inches		
	Min.	Nom.	Max.	Min.	Nom.	Max.
A	-	-	1.45	-	-	0.057
A1	0	0.08	0.15	0	0.003	0.006
A2	0.9	1.1	1.3	0.035	0.043	0.051
b	0.3	0.4	0.5	0.012	0.016	0.02
C	0.08	0.15	0.22	0.003	0.006	0.009
D	2.7	2.9	3.1	0.106	0.114	0.122
E1	1.4	1.6	1.8	0.055	0.063	0.071
E	2.6	2.8	3	0.102	0.11	0.118
L	0.3	0.45	0.6	0.012	0.018	0.024
L1	0.5	0.6	0.7	0.02	0.024	0.028
e1	1.9 BSC			0.075 BSC		
e	0.95 BSC			0.037 BSC		
$\theta$	0°	4°	8°	0°	4°	8°
$\theta 1$	5°	10°	15°	5°	10°	15°
$\theta 2$	5°	10°	15°	5°	10°	15°

JEDEC outline: MO-178 AA

(2) TDFN-6L (2\*2 0.75mm)

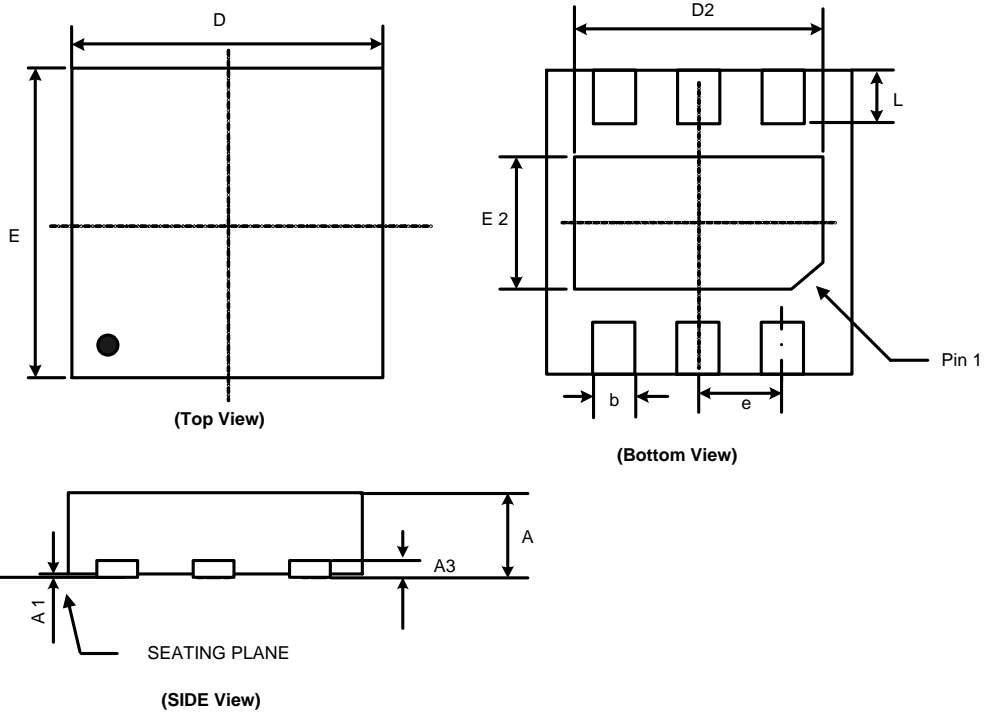

Symbol	Dimensions in Millimeters			Dimensions in Inches		
	Min.	Nom.	Max.	Min.	Nom.	Max.
A	0.7	0.75	0.8	0.028	0.03	0.031
A1	0	0.02	0.05	0	0.001	0.002
A3	0.203 REF.			0.008 REF.		
b	0.2	0.28	0.35	0.009	0.011	0.013
D	1.95	2	2.05	0.077	0.079	0.081
D2	1.0	1.5	1.7	0.039	0.059	0.067
E	1.95	2	2.05	0.077	0.079	0.081
E2	0.5	0.9	1.1	0.02	0.035	0.043
e	0.65 BSC.			0.026 BSC.		
L	0.2	0.3	0.4	0.008	0.012	0.016

❖ Carrier tape dimension

SOT-23-5L

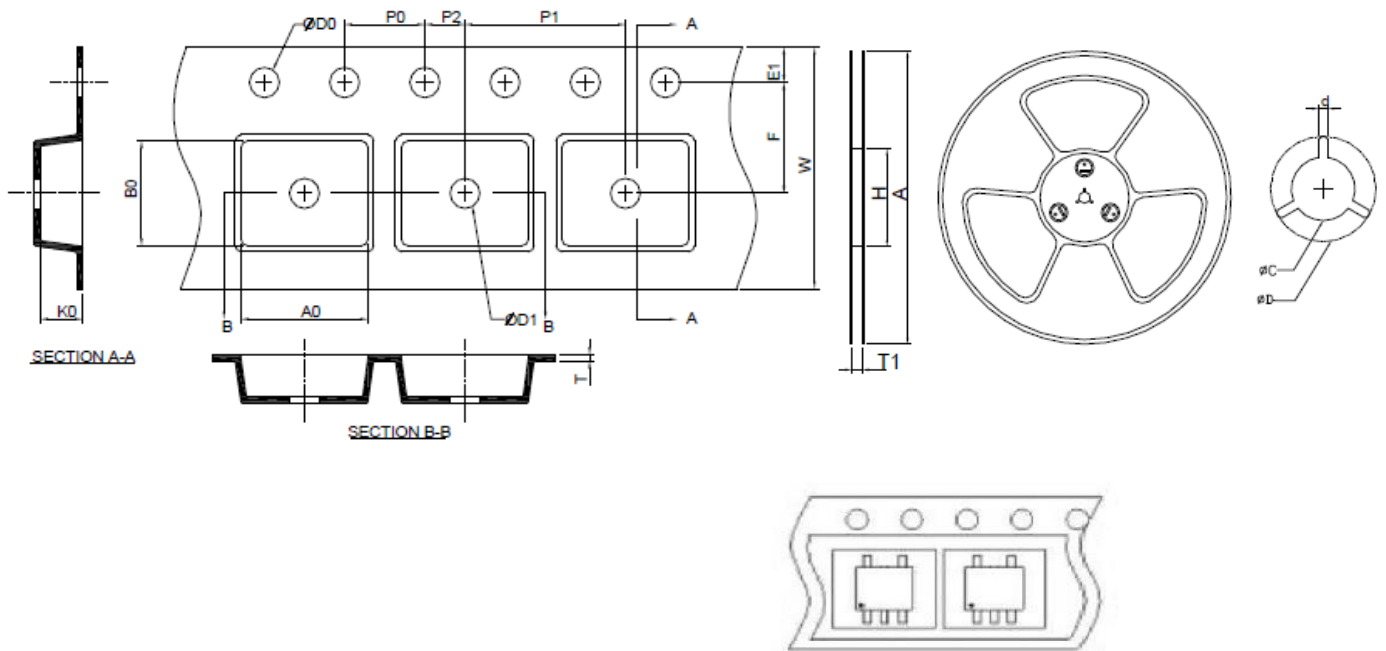

A	H	T1	C	d	D	W	E1	F
178.0±2.00	50 MIN.	8.4+2.00 -0.00	13.0+0.50 -0.20	1.5 MIN.	20.2 MIN.	8.0±0.30	1.75±0.10	3.5±0.05
P0	P1	P2	D0	D1	T	A0	B0	K0
4.0±0.10	4.0±0.10	2.0±0.05	1.5+0.10 -0.00	1.0 MIN.	0.6+0.00 -0.40	3.20±0.20	3.10±0.20	1.50±0.20

(mm)

TDFN 2x2

