

5A Low Dropout Linear Regulator

❖ GENERAL DESCRIPTION

AX1008 is a low dropout positive adjustable or fixed-mode regulator with minimum of 5.0A output current capability. The product is specifically designed to provide well-regulated supply for low voltage IC applications such as high-speed bus termination and low current 3.3V logic supply. AX1008 is also well suited for other applications such as VGA cards. AX1008 is guaranteed to have lower than 1.5V dropout at full load current making it ideal to provide well-regulated outputs of 1.2V to 5V.

❖ FEATURES

- 1.5V maximum dropout at full load current
- Built-in thermal shutdown
- Output current limiting
- Adjustable and 1.2V/1.5V/1.8V/2.5V/3.3V/5.0V fixed output voltages
- 10uF or greater MLCCs are available for stability
- Fast transient response
- Good noise rejection
- Package: TO252-3L, TO263-2L
- RoHS and Halogen free compliance

❖ BLOCK DIAGRAM

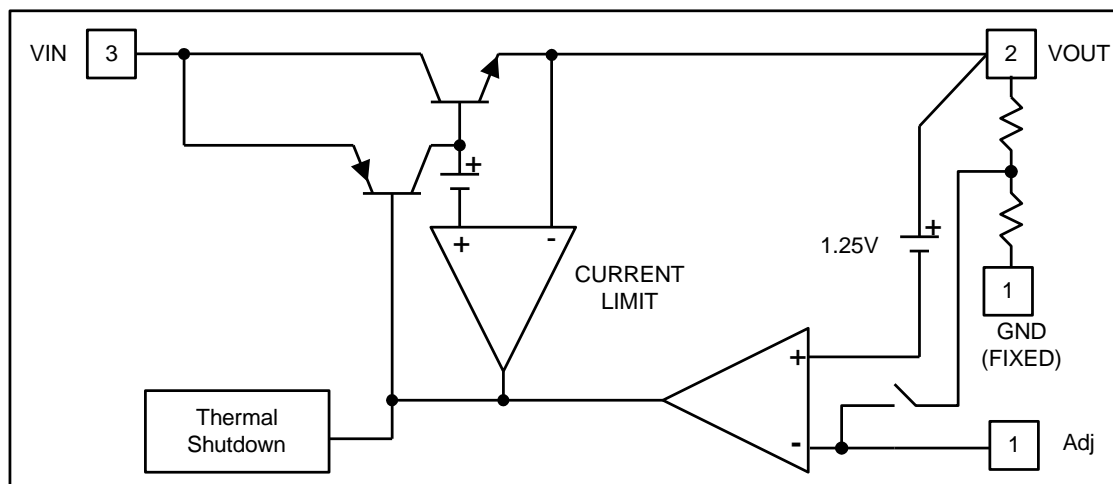

❖ **PIN ASSIGNMENT**

The packages of AX1008 are TO263-2L and TO252-3L; the pin assignment is given by:

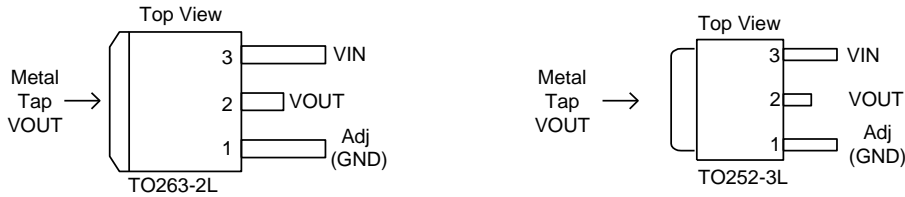

Name	Description
Adj (GND)	Adjustable (Ground only for fixed version) A resistor divider from this pin to the V _{OUT} pin and ground sets the output voltage.
VOUT	The output of the regulator. A minimum of 100uF aluminum electrolytic capacitor (ESR ≤ 5Ω) or 10uF MLCC must be connected from this pin to ground to insure stability.
VIN	The input pin of regulator. Typically a large storage capacitor (ESR ≤ 5Ω) is connected from this pin to ground to insure that the input voltage does not sag below the minimum dropout voltage during the load transient response. This pin must always be 1.4V higher than V _{OUT} in order for the device to regulate properly.

❖ **ORDER/MARKING INFORMATION**

Order Information	
AX1008 X XX X Package Vout Packing D : TO252-3L Blank : Adj Blank : Tube M : TO263-2L 12 = 1.2V A : Taping 15 = 1.5V 18 = 1.8V 25 = 2.5V 33 = 3.3V 50 = 5.0V	
Top Marking	
ADJ Version Logo ← AX1008 → Part number YYWWX → ID code : internal WW : 01~52 Year: 18=2018 19=2019 20=2020 21=2021 22=2022 : 45 = 2045	Fixed Version Logo ← AX1008 → Part number -VV → Output Voltage 12 = 1.2V 15 = 1.5V 18 = 1.8V 25 = 2.5V 33 = 3.3V 50 = 5.0V YYWWX Year: 18=2018 19=2019 20=2020 21=2021 22=2022 : 45 = 2045 → ID code: internal → WW: 01~52

❖ ABSOLUTE MAXIMUM RATINGS (at $T_A=25^{\circ}\text{C}$)

Characteristics	Symbol	Rating	Unit
DC Supply Voltage	V_{IN}	-0.3 to 12	V
Power Dissipation	P_D	Internally Limited	
Storage Temperature	T_{ST}	-65 to +150	$^{\circ}\text{C}$
Operating Junction Temperature Range	T_{OPJ}	-40 to +125	$^{\circ}\text{C}$
Maximum junction Temperature	T_{MJ}	150	$^{\circ}\text{C}$

❖ ELECTRICAL CHARACTERISTICS
 $(V_{IN} = V_{EN}=3.6\text{V}, T_A = 25^{\circ}\text{C}, \text{ unless otherwise specified})$

Characteristics	Symbol	Conditions (Notes)	Min.	Typ.	Max.	Units
Reference Voltage	V_{REF}	$I_{OUT}=10\text{mA}, T_J=25^{\circ}\text{C}, (V_{IN}-V_{OUT})=1.5\text{V}$	1.225	1.250	1.275	V
Output Voltage (Fixed Version)	V_{OUT}	$I_{OUT}=10\text{mA}, T_J = 25^{\circ}\text{C}, 2.7\text{V} \leq V_{IN} \leq 12\text{V}$	1.175	1.200	1.225	V
		$I_{OUT} = 10\text{mA}, T_J = 25^{\circ}\text{C}, 3\text{V} \leq V_{IN} \leq 12\text{V}$	1.470	1.500	1.530	V
		$I_{OUT} = 10\text{mA}, T_J = 25^{\circ}\text{C}, 3.3\text{V} \leq V_{IN} \leq 12\text{V}$	1.764	1.800	1.836	V
		$I_{OUT} = 10\text{mA}, T_J = 25^{\circ}\text{C}, 4\text{V} \leq V_{IN} \leq 12\text{V}$	2.450	2.500	2.550	V
		$I_{OUT} = 10\text{mA}, T_J = 25^{\circ}\text{C}, 4.8\text{V} \leq V_{IN} \leq 12\text{V}$	3.235	3.300	3.365	V
		$I_{OUT} = 10\text{mA}, T_J = 25^{\circ}\text{C}, 6.5\text{V} \leq V_{IN} \leq 12\text{V}$	4.900	5.000	5.100	V
		Line Regulation		$I_{OUT}=10\text{mA}, V_{OUT}+1.5\text{V}<V_{IN}<12\text{V}, T_J=25^{\circ}\text{C}$	-	0.3
Load Regulation		$V_{IN}=V_{OUT}+1.5\text{V}, 10\text{mA} \leq I_{OUT} \leq 5\text{A}, T_J=25^{\circ}\text{C}$ (Note 1,2)	-	0.7	1.5	%
Dropout Voltage	ΔV_o	$I_{OUT}=5.0\text{A}$ ($\Delta V_{OUT}=1\% V_{OUT}$)	-	1.3	1.5	V
Current Limit		$V_{IN}-V_{OUT}=3\text{V}$	5.1	-	-	A
Minimum Load Current			-	5	10	mA
Ripple Rejection		$F=120\text{Hz}, C_{OUT}=10\mu\text{f}$ AX1008-XXX $V_{IN}=V_{OUT}+3\text{V}$	-	60	70	dB
Temperature Stability		$I_{OUT}=10\text{mA}$	-	0.5	-	%
Thermal shutdown Temp (Over temperature protect)	T_{SD}		-	145	-	$^{\circ}\text{C}$
Thermal Shutdown Hysteresis	T_{SH}		-	40	-	$^{\circ}\text{C}$
Thermal Resistance Junction-to-Ambient (Note 3)	θ_{JA}	TO-252	-	55	-	$^{\circ}\text{C}/\text{W}$
		TO-263	-	45	-	$^{\circ}\text{C}/\text{W}$
Thermal Resistance Junction-to-Case	θ_{JC}	TO-252	-	10	-	$^{\circ}\text{C}/\text{W}$
		TO-263	-	2.7	-	$^{\circ}\text{C}/\text{W}$

Note 1: See thermal regulation specifications for changes in output voltage due to heating effects. Line and load regulation are measured at a constant junction temperature by low duty cycle pulse testing. Load regulation is measured at the output lead = 1/18" from the package.

Note 2: Line and load regulation are guaranteed up to the maximum power dissipation of 15W. Power dissipation is determined by the difference between input and output and the output current. Guaranteed maximum power dissipation will not be available over the full input/output range.

Note 3: Output is connected to the multi-layer PCB copper area 10mm*5.5mm separately. If you need large PD or lower Tc and Tj, please connect to the large copper area >>10mm*5.5mm (like 10mm*10mm).

❖ APPLICATION CIRCUIT

(1) EL CAP

5.0V to 3.3V Fixed Mode Regulator

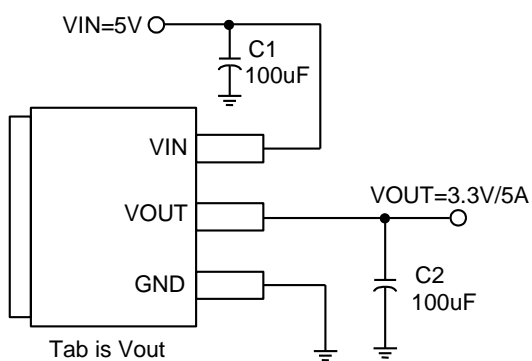

Adjustable Regulator

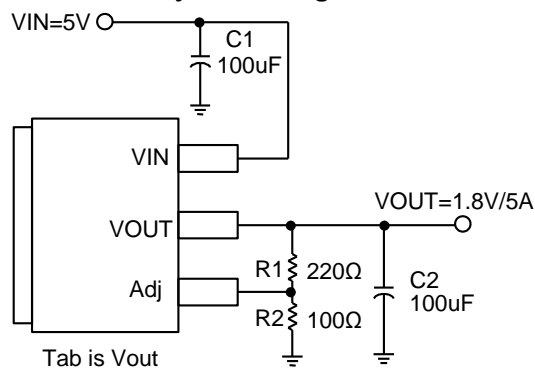

$$V_{OUT} = V_{REF} * \left(1 + \frac{R_2}{R_1}\right)$$

(2) MLCC

5.0V to 3.3V Fixed Mode Regulator

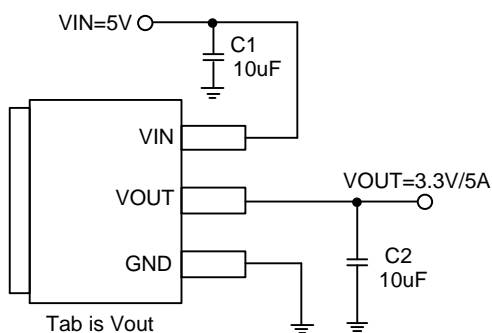

Adjustable Regulator

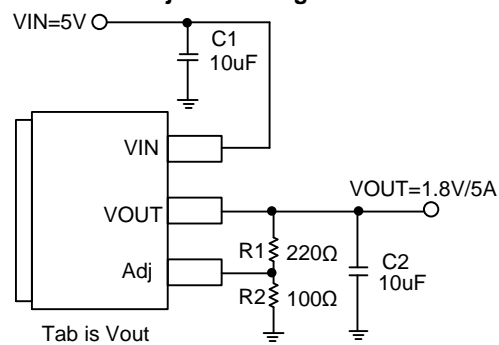

$$V_{OUT} = V_{REF} * \left(1 + \frac{R_2}{R_1}\right)$$

❖ **FUNCTION DESCRIPTIONS**

Introduction

The AX1008 adjustable Low Dropout (LDO) regulator is a 3 terminal device that can easily be programmed with the addition of two external resistors to any voltages within the range of 1.25V to $V_{IN}-1.5V$. The AX1008 only needs 1.5V differential between V_{IN} and V_{OUT} to maintain output regulation. In addition, the output voltage tolerances are also extremely tight and they include the transient response as part of the specification. For example, Intel VRE specification calls for a total of +/- 100mV including initial tolerance, load regulation and 0 to 5.0A load step.

The AX1008 is specifically designed to meet the fast current transient needs as well as providing an accurate initial voltage, reducing the overall system cost with the need for fewer output capacitors.

Output Voltage Setting

The AX1008 can be programmed to any voltages in the range of 1.25V to $V_{IN}-1.5V$ with the addition of R1 and R2 external resistors according to the following formula:

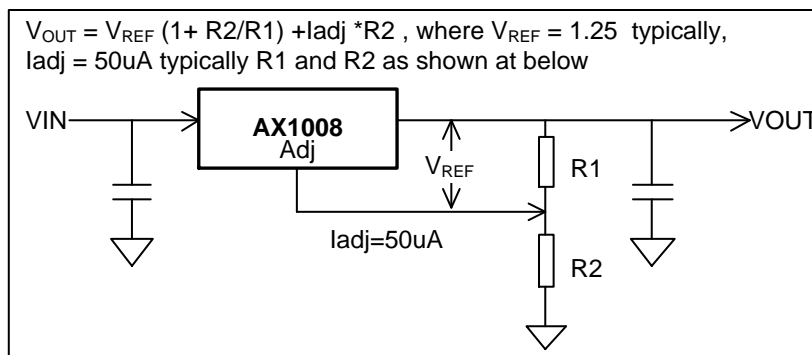

The AX1008 keeps a constant 1.25V between the output pin and the adjust pin. By placing a resistor R1 across these two pins a constant current flows through R1, adding to the I_{adj} current and into the R2 resistor producing a voltage equal to the $(1.25/R1)*R2 + I_{adj}*R2$ which will be added to the 1.25V to set the output voltage. This is summarized in the above equation. Since the minimum load current requirement of the AX1008 is 10mA, R1 is typically selected to be 121Ω resistor so that it automatically satisfies the minimum current requirement. Notice that since I_{adj} is typically in the range of 50uA it only adds a small error to the output voltage and should only be considered when a very precise output voltage setting is required. For example, in a typical 3.3V application where $R1=121\Omega$ and $R2=200\Omega$ the error due to I_{adj} is only 0.3% of the nominal set point.

Load Regulation

Since the AX1008 is only a 3 terminal device, it is not possible to provide true remote sensing of the output voltage at the load. The best load regulation is achieved when the bottom side of R2 is connected to the load and the top-side of R1 resistor is connected directly to the case or the V_{OUT} pin of the regulator and not to the load. It is important to note that for high current applications, this can re-present a significant percentage of the overall load regulation and one must keep the path from the regulator to the load as short as

possible to minimize this effect.

Stability

The AX1008 requires the use of an output capacitor as part of the frequency compensation in order to make the regulator stable. For most applications a minimum of 100uF aluminum electrolytic capacitor or 10uF MLCC insures stability .

Thermal Design

The AX1008 incorporates an internal thermal shutdown that protects the device when the junction temperature exceeds the maximum allowable junction temperature. Although this device can operate with junction temperatures in the range of 150°C, it is recommended that the selected heat sink be chosen such that during maximum continuous load operation the junction temperature is kept below the temperature.

Layout Consideration

The output capacitors must be located as close to the V_{OUT} terminal of the device as possible. It is recommended to use a section of a layer of the PC board as a plane to connect the V_{OUT} pin to the output capacitors to prevent any high frequency oscillation that may result due to excessive trace inductance.

❖ TYPICAL CHARACTERISTICS

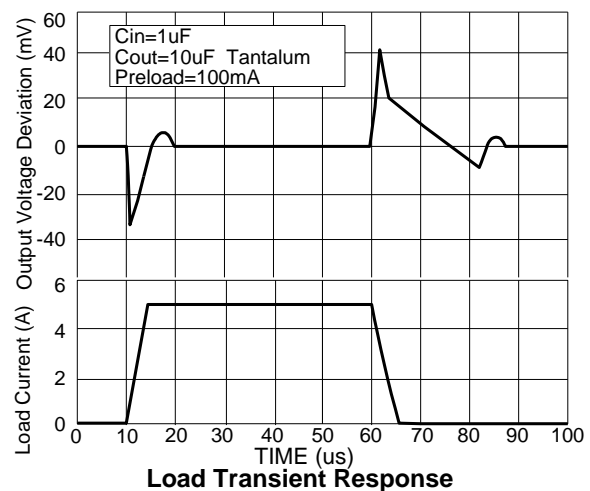
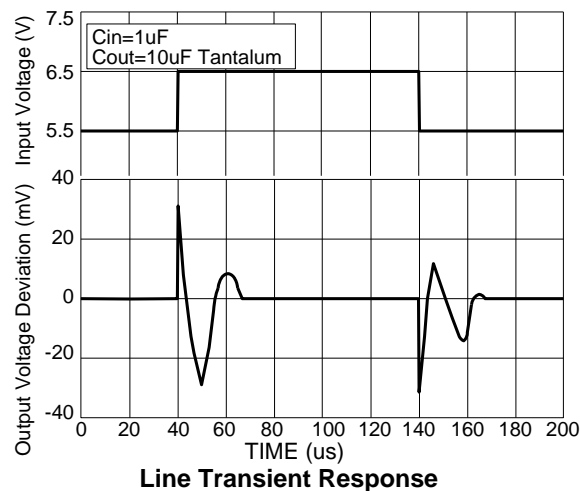
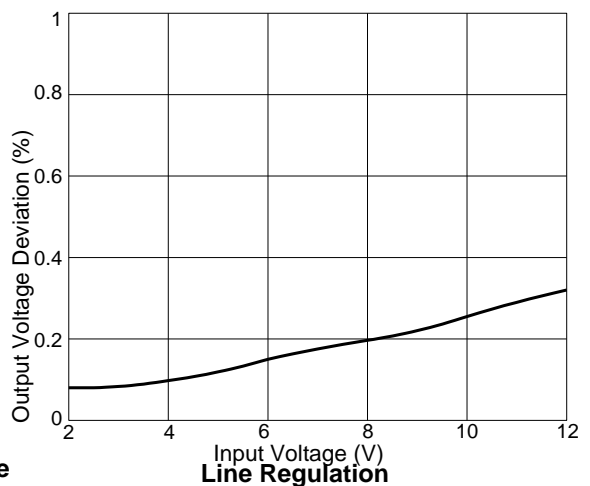
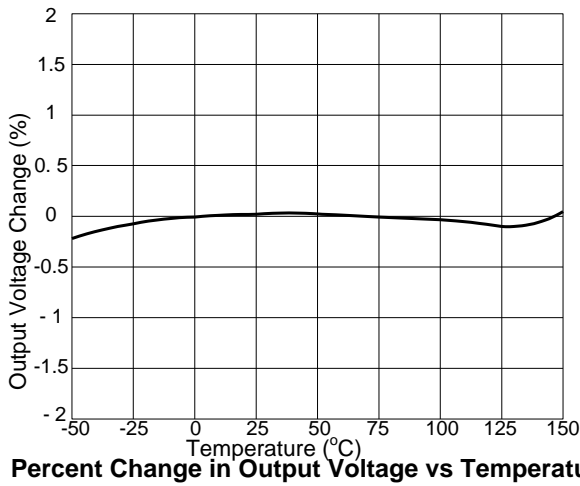
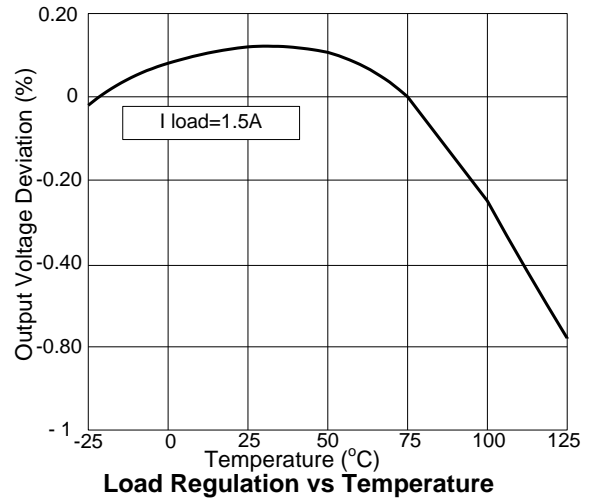
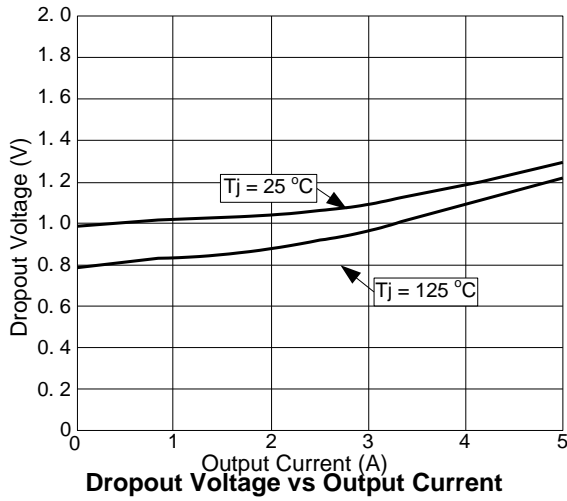

❖ PACKAGE OUTLINES

(1) TO263-2L

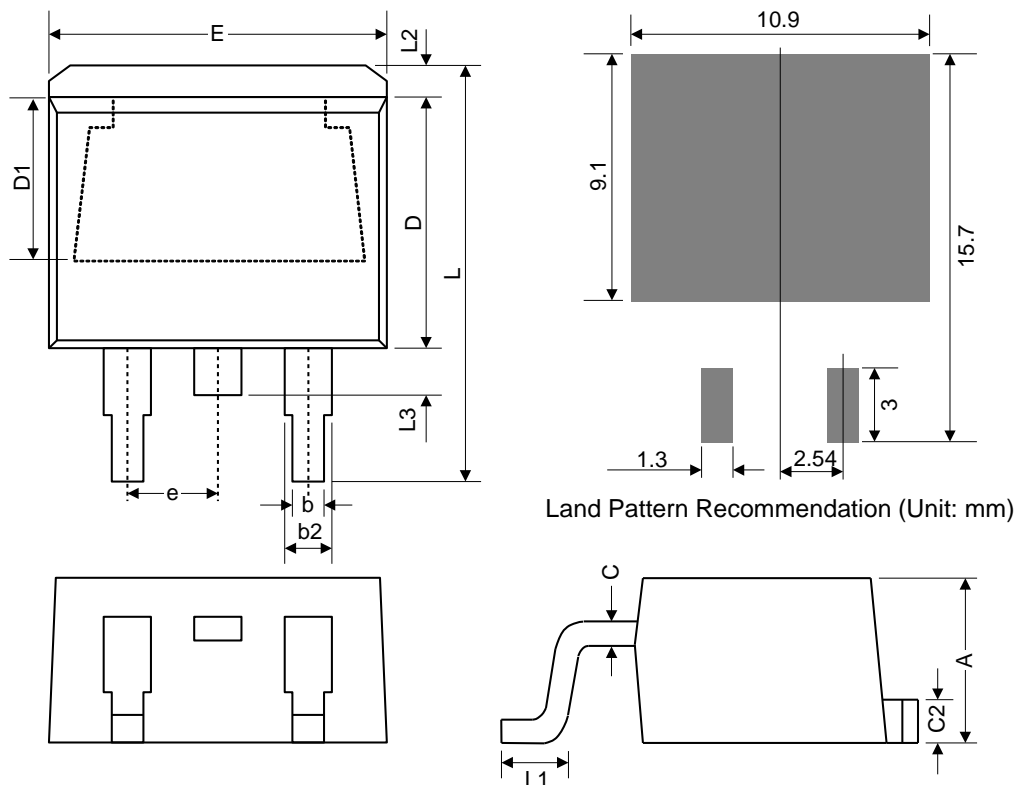

Symbol	Dimensions in Millimeters			Dimensions in Inches		
	Min.	Nom.	Max.	Min.	Nom.	Max.
A	4.06	4.45	4.83	0.16	0.175	0.19
b	0.51	0.76	0.99	0.02	0.03	0.039
b2	1.14	1.47	1.78	0.045	0.058	0.07
C	0.38	0.56	0.74	0.015	0.022	0.029
C2	1.14	1.4	1.65	0.045	0.055	0.065
D	8.38	9.02	9.65	0.33	0.355	0.38
D1	5.08	-	-	0.2	-	-
E	9.65	10.2	10.7	0.38	0.4	0.42
e	2.54 BSC			0.1 BSC		
L	14.6	15.2	15.9	0.575	0.6	0.625
L1	1.78	2.29	2.79	0.07	0.09	0.11
L2	-	-	1.68	-	-	0.066
L3	-	-	1.78	-	-	0.07

Mold flash shall not exceed 0.005inch per side
JEDEC outline: TO-263 AB

(2) TO252-3L

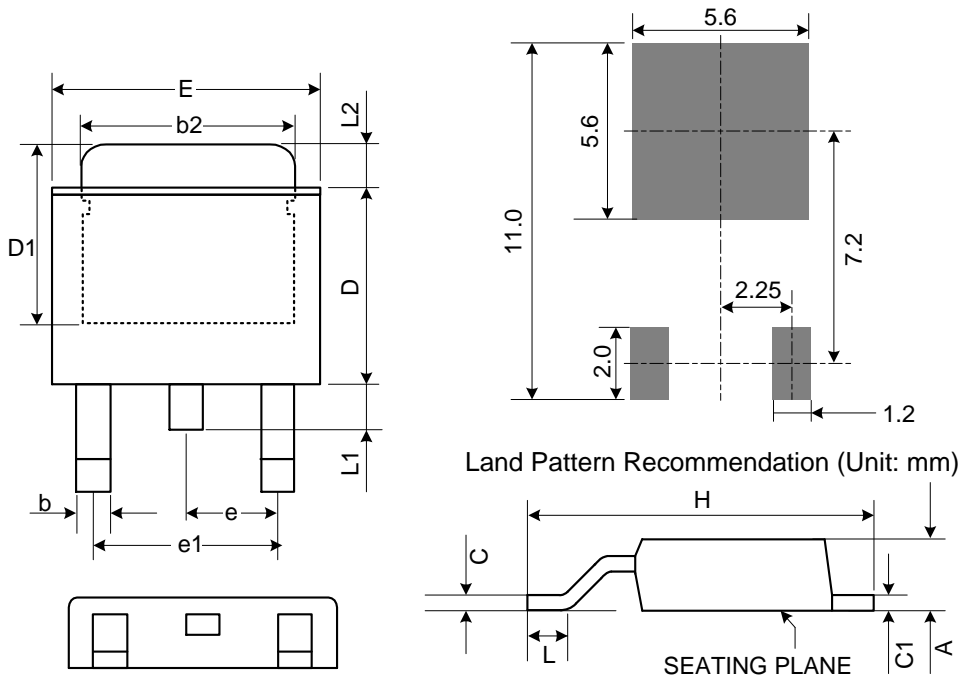

Symbol	Dimensions in Millimeters			Dimensions in Inches		
	Min.	Nom.	Max.	Min.	Nom.	Max.
A	2.18	-	2.39	0.086	-	0.094
b	0.64	-	0.89	0.025	-	0.035
b2	4.95	-	5.46	0.195	-	0.215
C	0.46	-	0.61	0.018	-	0.024
C1	0.46	-	0.89	0.018	-	0.035
D	5.33	-	6.22	0.21	-	0.245
D1	4.57	-	-	0.18	-	-
E	6.35	-	6.73	0.25	-	0.265
e	2.29 BSC			0.090 BSC.		
e1	4.58 BSC			0.180 BSC.		
H	9.4	-	10.4	0.37	-	0.41
L	1.4	1.52	1.78	0.055	0.06	0.07
L1	-	-	1.02	-	-	0.04
L2	0.89	-	2.03	0.035	-	0.08

Mold flash shall not exceed 0.005inch per side

JEDEC outline: TO-252 AA / AB

❖ Carrier tape dimension

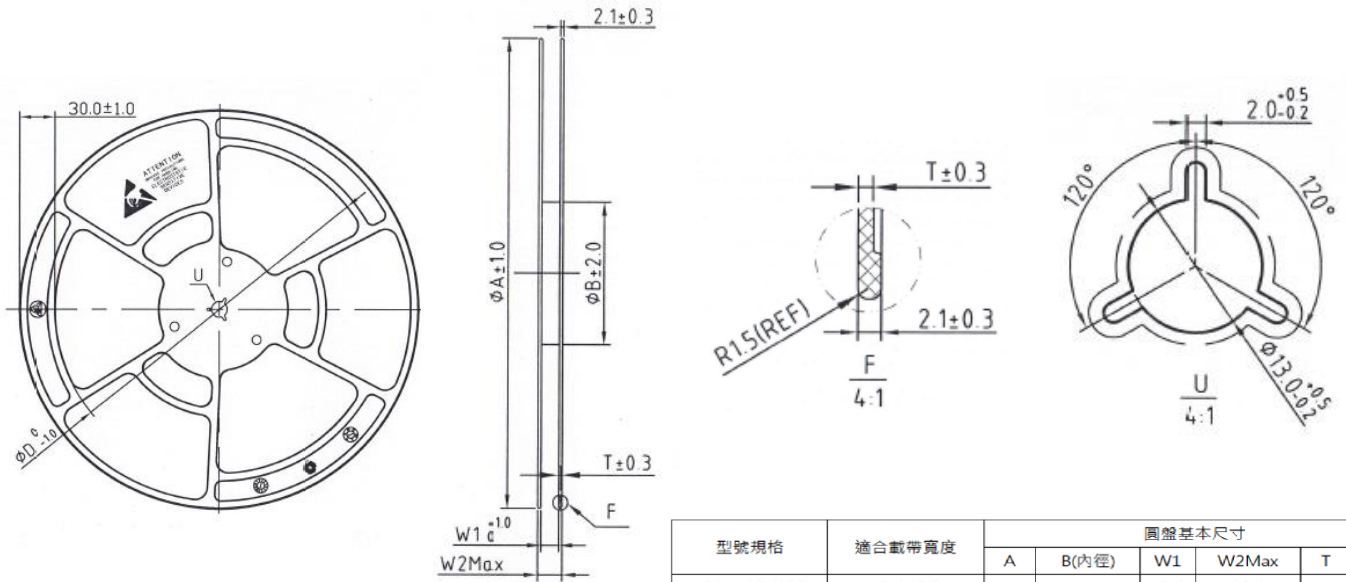
TO-252-3L

型號規格	適合載帶寬度	圓盤基本尺寸					
		A	B(內徑)	W1	W2Max	T	D
13" - 12X100	12 / 12.2	330	100	12.4	18.4	1.5	270
13" - 16X100	16			16.4	22.4		
13" - 24X100	24			24.4	30.4		

(mm)

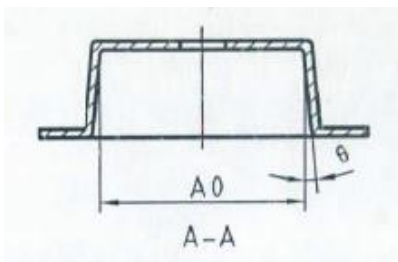
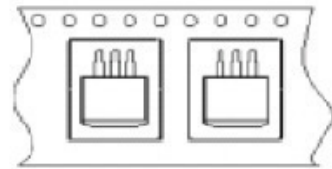
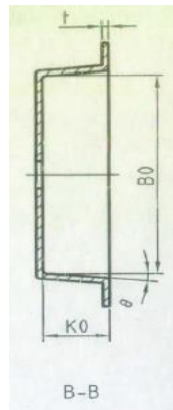
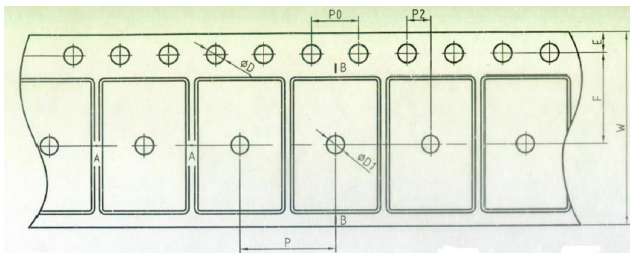

E	F	P ₂	D	D ₁	P ₀	10P ₀
1.75 ± 0.10	7.50 ± 0.10	2.00 ± 0.10	$1.50 \begin{smallmatrix} +0.1 \\ 0 \end{smallmatrix}$	$1.50 \begin{smallmatrix} -0.25 \\ 0 \end{smallmatrix}$	4.00 ± 0.10	40.0 ± 0.20
W	P	A ₀	B ₀	K ₀	t	θ
16.00 ± 0.10	8.00 ± 0.10	6.90 ± 0.10	10.50 ± 0.10	2.65 ± 0.10	0.30 ± 0.02	5°TYP

(mm)

TO263-2L

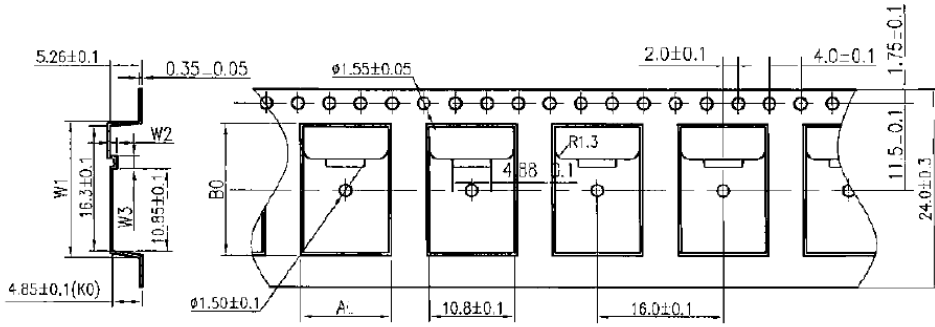

W1	17.2±0.1
W2	1.8±0.1
W3	0.85±0.1

(mm)

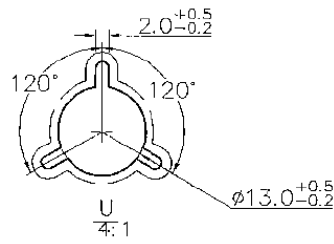
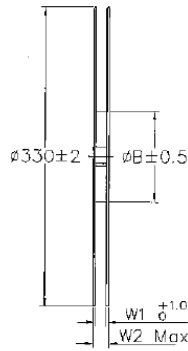
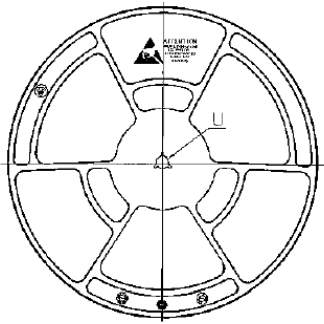

產品類別	載帶寬度	B(內徑)	W1	W2max
TO263	24	100	24.4	30.4

(mm)