

1.2V 350mA Low Dropout Linear Regulator

❖ GENERAL DESCRIPTION

AX1112 is a low dropout positive fixed-mode regulator with minimum of 350mA output current capability. The product is specifically designed to provide well-regulated supply for low voltage IC applications such as high-speed bus termination and low current 3.3V logic supply. AX1112 is also well suited for other applications such as VGA cards. AX1112 is guaranteed to have lower than 1.2V dropout at full load current making it ideal to provide well-regulated outputs.

❖ FEATURES

- Fixed 1.2V \pm 2% output voltage
- Fast transient response
- Output current limiting
- Built-in thermal shutdown
- Good noise rejection
- Packages: SOT23-3L
- RoHS and Halogen free compliance

❖ BLOCK DIAGRAM

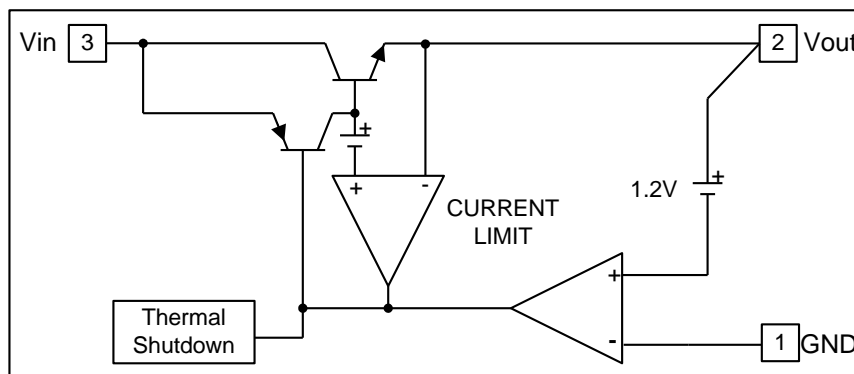

❖ PIN ASSIGNMENT

The package of AX1112 is SOT23-3L; the pin assignment is given by:

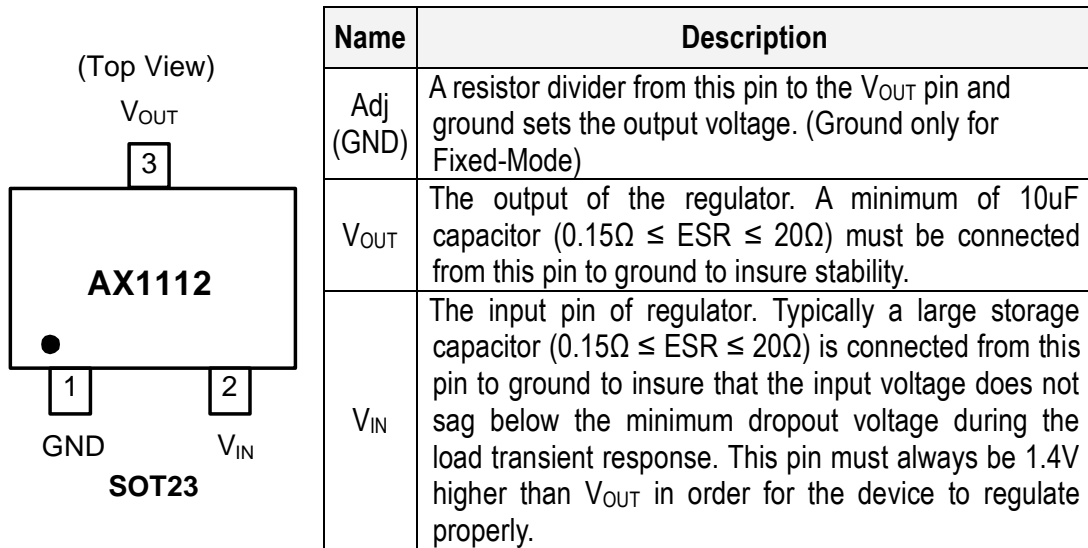

❖ ORDER/MARKING INFORMATION

Order Information	Top Marking
<p>AX 1112 X X</p> <p>Package: R: SOT23-3L</p> <p>Packing: Blank : Bag, A : Taping</p>	<p>Output Type: ← L L Y W X → ID Code: internal DB : 1.2V</p> <p>WW : 01~26(A~Z) 27~52(a~z)</p> <p>Year: 8=2018 9=2019 B=2020 C=2021 D=2022 : Z=2044</p>

❖ ABSOLUTE MAXIMUM RATINGS

Parameter	Symbol	Rating	Unit
DC Supply Voltage	V _{in}	-0.3 to 15	V
Operating Junction Temperature Range	T _{OP}	-40 to +125	°C
Maximum junction Temperature	T _{MJ}	150	°C
Power Dissipation (multi-layer PCB copper area 2mm*2mm) T _A =25°C, T _J =125°C, SOT-23	P _D	450	mW
Storage Temperature	T _{ST}	-65 to +150	°C

❖ **ELECTRICAL CHARACTERISTICS**

(Under Operating Conditions)

Characteristics	Conditions	Min	Typ	Max	Units
Operation Input Voltage	$I_{OUT} = 350\text{mA}$	2.5	-	12	V
Reference Voltage	$I_{OUT} = 10\text{mA}$, $2.5 \leq V_{IN} \leq 12\text{V}$, $T_J = 25^\circ\text{C}$	1.176	1.200	1.224	V
Line Regulation	$I_{OUT} = 10\text{mA}$, $2.5 \leq V_{IN} \leq 12\text{V}$, $T_J = 25^\circ\text{C}$ (Note 1,2)	-	1.2	6	mV
Load Regulation	$V_{IN}=2.5\text{V}$, $10\text{mA} < I_{OUT} < 350\text{mA}$, $T_J=25^\circ\text{C}$ (Note 1,2)	-	-	12	mV
Dropout Voltage ($V_{IN}-V_{OUT}$)	$I_{OUT} = 350\text{mA}$, $\Delta V_{OUT}=1\%V_{OUT}$	-	1.1	1.2	V
Current Limit	$(V_{IN}-V_{OUT}) = 2\text{V}$	0.5	-	-	A
Minimum Load Current	$0^\circ\text{C} \leq T_J \leq 125^\circ\text{C}$	-	5	10	mA
Ripple Rejection	$F=120\text{Hz}$, $C_{OUT}=25\mu\text{F}$ Tantalum, $I_{OUT}=350\text{mA}$	-	60	70	dB
Temperature Stability	$I_{OUT}=10\text{mA}$	-	0.5	-	%
θ_{JA} Thermal Resistance Junction-to-Ambient (Note4)	SOT-23	-	220	-	$^\circ\text{C/W}$
θ_{JC} Thermal Resistance Junction-to-Case	SOT-23	-	120	-	$^\circ\text{C/W}$

Note1: See thermal regulation specifications for changes in output voltage due to heating effects. Line and load regulation are measured at a constant junction temperature by low duty cycle pulse testing. Load regulation is measured at the output lead = 1/18" from the package.

Note2: Line and load regulation are guaranteed up to the maximum power dissipation of 5W. Power dissipation is determined by the difference between input and output differential and the output current. Guaranteed maximum power dissipation will not be available over the full input/output range.

Note3: Quiescent current is defined as the minimum output current required in maintaining regulation. At 12V input/output differential the device is guaranteed to regulate if the output current is greater than 10mA.

Note4: V_{OUT} Pin is connected to the multi-layer PCB copper area 2mm*2mm

❖ **APPLICATION CIRCUIT**

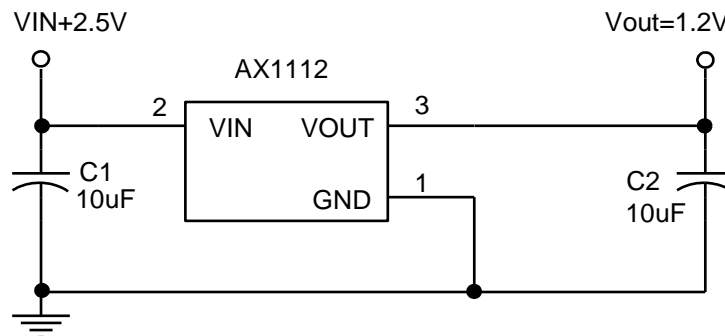

❖ TYPICAL CHARACTERISTICS

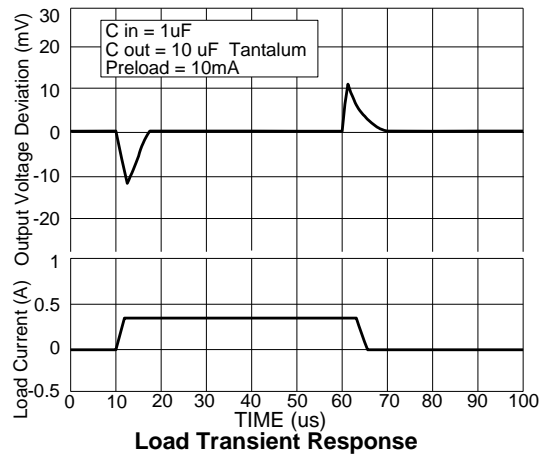
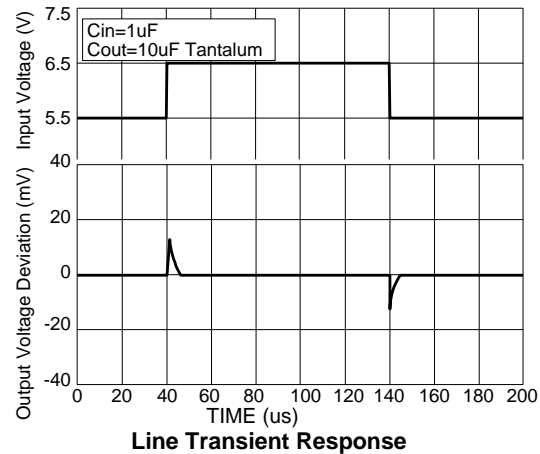
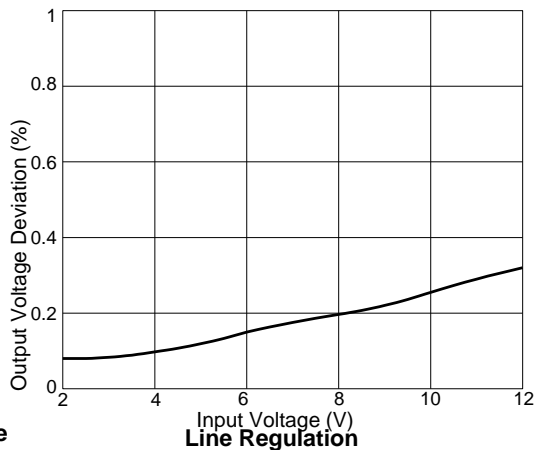
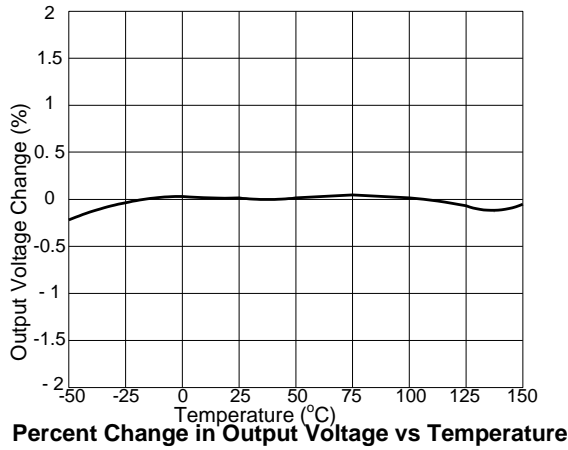
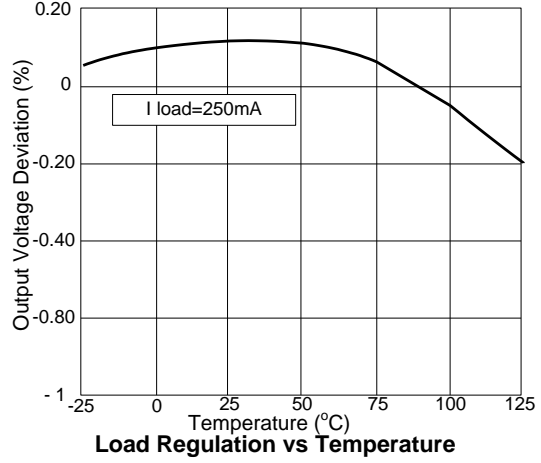
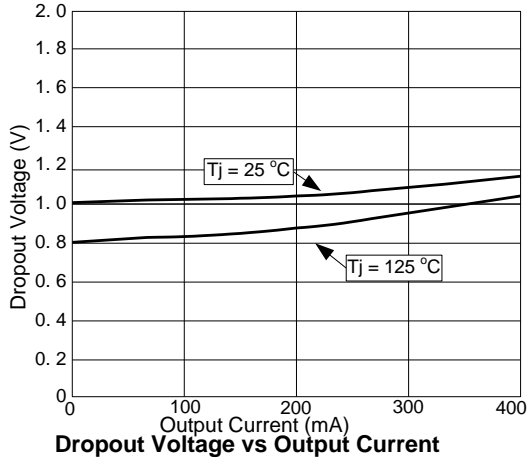

❖ PACKAGE OUTLINES

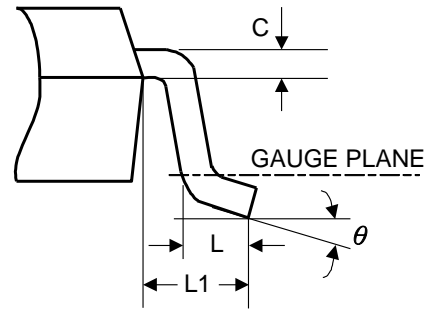
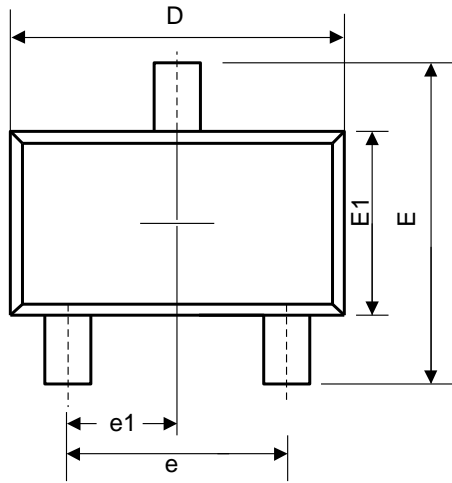

VIEW C

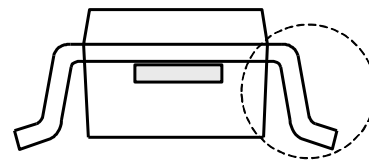
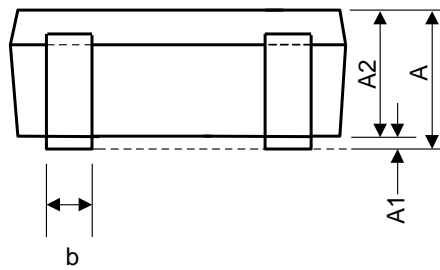

SEE VIEW C

Symbol	Dimensions in Millimeters			Dimensions in Inches		
	Min.	Nom.	Max.	Min.	Nom.	Max.
A	1.05	-	1.45	0.041	-	0.057
A1	0.05	-	0.15	0.002	-	0.006
A2	0.90	1.10	1.30	0.035	0.043	0.051
b	0.30	-	0.50	0.012	-	0.020
C	0.08	-	0.20	0.003	-	0.008
D	2.70	2.90	3.10	0.106	0.114	0.122
E	2.60	2.80	3.00	0.102	0.110	0.118
E1	1.40	1.60	1.80	0.055	0.063	0.071
L	0.30	-	0.60	0.012	-	0.024
L1	0.50	0.60	0.70	0.020	0.024	0.028
e	1.80	1.90	2.00	0.071	0.075	0.079
e1	0.85	1.00	1.15	0.033	0.039	0.045
θ	0°	5°	10°	0°	5°	10°

❖ Carrier tape dimension

SOT23-3L

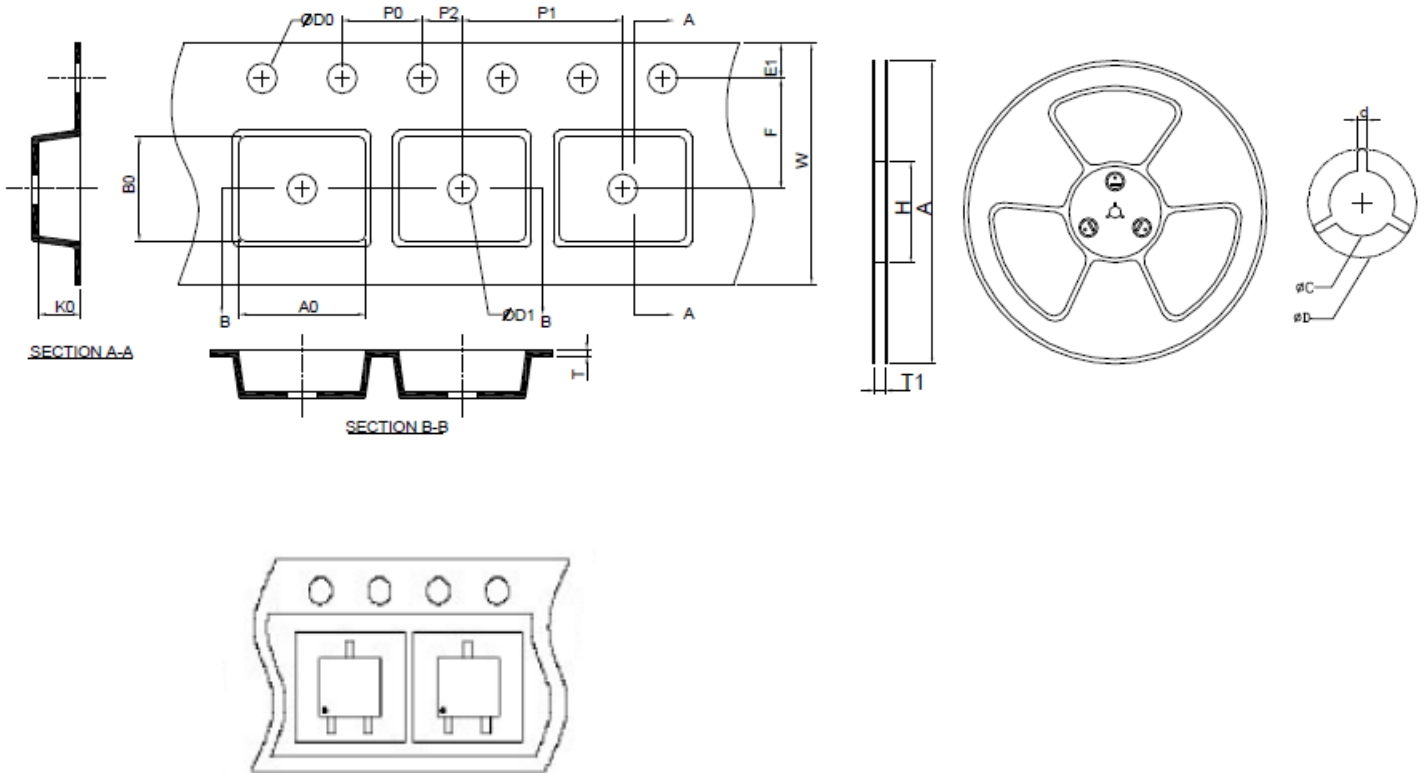

A	H	T1	C	d	D	W	E1	F
178.0±2.00	50 MIN.	8.4+2.00 -0.00	13.0+0.50 -0.20	1.5 MIN.	20.2 MIN.	8.0±0.30	1.75±0.10	3.5±0.05
P0	P1	P2	D0	D1	T	A0	B0	K0
4.0±0.10	4.0±0.10	2.0±0.05	1.5+0.10 -0.00	1.0 MIN.	0.6+0.00 -0.40	3.20±0.20	3.10±0.20	1.50±0.20

(mm)