

1.2A High Output Current LDO Regulator

❖ GENERAL DESCRIPTION

The AX6630/A is a low noise, high output current, low quiescent current and low dropout linear regulator. The Device includes pass element, error amplifier, band-gap, current-limit and thermal shutdown circuitry. The output current is up to 1.2A. The characteristics of low dropout voltage and less quiescent current make it good for some critical current application, for example, some battery powered devices. The typical quiescent current is approximately 50 μ A. Due to internal flexible design, result in extensively fixed output voltage versions form 1.0V to 5V per 0.1V steps. Built-in current-limit, Short current protection and thermal-shutdown functions prevent any fault condition from IC damage.

❖ FEATURES

- Input voltage range : 2.6V~5.5V
- Dropout voltage is 380mV at 1A output current
- Guaranteed 1.2A output current
- Low quiescent current is 50 μ A (typ.)
- Fixed Output voltage is form 1.0 V to 5V by 0.1V steps.
- Fast transient response
- Current limit and thermal shutdown protection
- Short circuit current fold-back
- Available in the 3-Pin Pb-Free SOT89, SOT-223, TO263 and TO252 packages
- RoHS and Halogen free compliance.

❖ BLOCK DIAGRAM

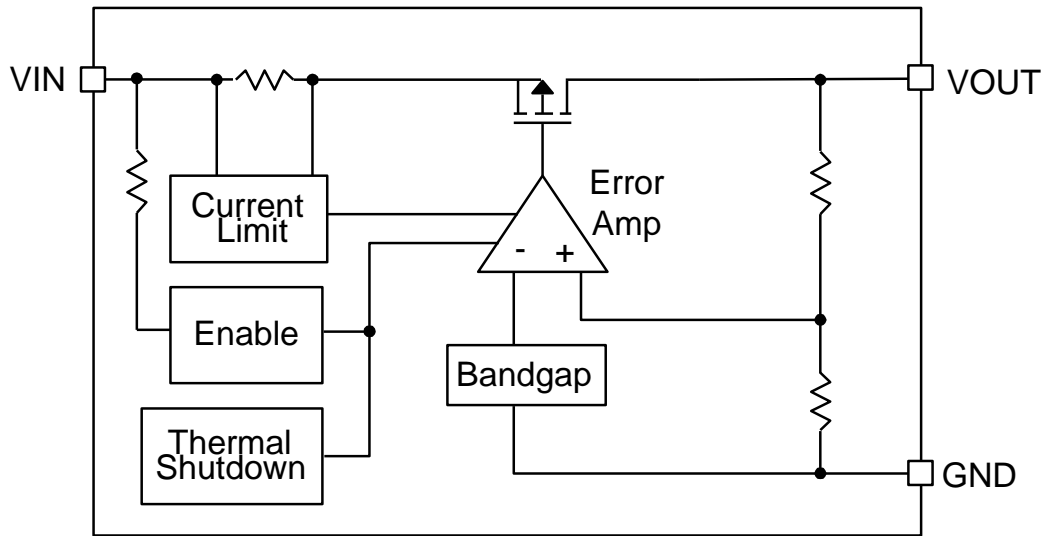

❖ PIN ASSIGNMENT

The packages of AX6630/A are SOT89-3L, SOT223-3L, TO252-3L and TO263-2L; the pin assignment is given by:

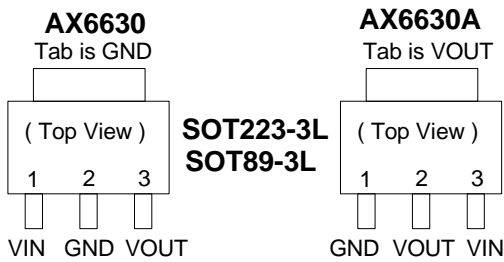

Name	Description
VIN	Voltage input
GND	Ground
VOUT	Output Voltage

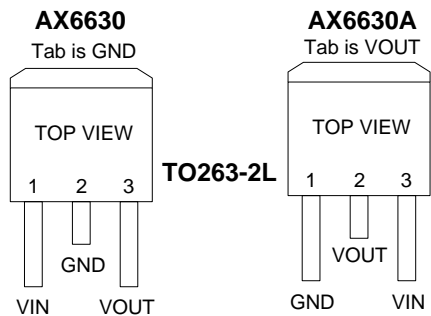
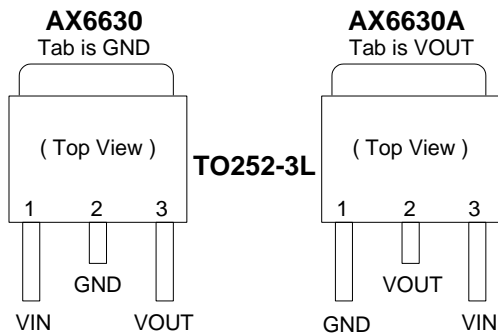

❖ ORDER/MARKING INFORMATION

Order Information	Top Marking (SOT89-3L)								
<p style="text-align: center;">AX6630X-XXX XX</p> <table border="1"> <tr> <th>Pin Define</th> <th>Output voltage</th> <th>Package</th> <th>Packing</th> </tr> <tr> <td>Refer Pin Assignment</td> <td>100 : 1.0V 110 : 1.1V ⋮ 500 : 5.0V</td> <td>E : SOT223-3L D:TO252-3L M:TO263-2L F:SOT89-3L</td> <td>Blank:Tube A : Taping</td> </tr> </table>	Pin Define	Output voltage	Package	Packing	Refer Pin Assignment	100 : 1.0V 110 : 1.1V ⋮ 500 : 5.0V	E : SOT223-3L D:TO252-3L M:TO263-2L F:SOT89-3L	Blank:Tube A : Taping	<p style="text-align: center;">6 6 3 0 X L Y W X</p> <p>Output Type</p> <ul style="list-style-type: none"> Functional code Blank: AX6630 A: AX6630A ID code: internal WW: 01~26(A~Z) 27~52(a~z) Year: 8=2018 9=2019 B=2020 C=2021 D=2022 ⋮ Z=2044 <p>Output Type:</p> <p>A:1.2V H:1.9V Q:2.6V X:3.3V f:4.0V r:4.7V B:1.3V J:2.0V R:2.7V Y:3.4V g:4.1V t:4.8V C:1.4V K:2.1V S:2.8V Z:3.5V h:4.2V u:4.9V D:1.5V L:2.2V T:2.9V a:3.6V m:4.3V y:5.0V E:1.6V M:2.3V U:3.0V b:3.7V n:4.4V z:1.0V F:1.7V N:2.4V V:3.1V d:3.8V o:4.5V i:1.1V G:1.8V P:2.5V W:3.2V e:3.9V q:4.6V</p>
Pin Define	Output voltage	Package	Packing						
Refer Pin Assignment	100 : 1.0V 110 : 1.1V ⋮ 500 : 5.0V	E : SOT223-3L D:TO252-3L M:TO263-2L F:SOT89-3L	Blank:Tube A : Taping						
Top Marking (SOT223-3L)	Top Marking (TO252-3L/TO263-2L)								
<p style="text-align: center;">AX 6 6 3 0 A - V V</p> <p>Blank: AX6630 A: AX6630A</p> <p>Y W W X → ID code: internal</p> <p>WW: 01~52</p> <p>Year: 8=2018 9=2019 B=2020 C=2021 D=2022 Z=2044</p> <p>Output Voltage AX6630-10: 1.0V AX6630-11: 1.1V ⋮ AX6630-50: 5.0V</p>	<p style="text-align: center;">AX 6 6 3 0 A - V V</p> <p>Blank: AX6630 A: AX6630A</p> <p>Y Y W W X → ID code: internal</p> <p>WW: 01~52</p> <p>Year: 18=2018 19=2019 20=2020 21=2021 22=2022 ⋮ 45=2045</p> <p>Output Voltage AX6630-10: 1.0V AX6630-11: 1.1V ⋮ AX6630-50: 5.0V</p>								

❖ ABSOLUTE MAXIMUM RATINGS (at T_A=25°C)

Characteristics		Symbol	Rating	Unit
V _{IN} Pin Voltage		V _{IN}	GND - 0.3 to GND + 6	V
Output Voltage		V _{OUT}	GND - 0.3 to V _{IN} + 0.3	V
Power Dissipation		PD	SOT89=0.6,SOT223=1.3 TO263=4,TO252=2.2	W
Storage Temperature Range		T _{ST}	-40 to +150	°C
Operating Temperature Range		T _{OP}	-40 to +85	°C
Junction Temperature		T _J	-40 to +125	°C
Thermal Resistance from Junction to case	SOT223	θ _{JC}	15	°C/W
	TO263		3.5	
	TO252		10	
	SOT89		100	
Thermal Resistance from Junction to ambient	SOT223	θ _{JA}	75	°C/W
	TO263		25	
	TO252		45	
	SOT89		160	

Note : θ_{JA} is measured with the PCB copper area of approximately 1 in²(Multi-layer). That need connect to tap pin.

❖ **ELECTRICAL CHARACTERISTICS** $T_A=25^{\circ}\text{C}$ (unless otherwise noted)

Characteristics	Symbol	Conditions	Min	Typ	Max	Units	
Input Voltage	V_{IN}	(Note1)	2.6	-	5.5	V	
Output Voltage Accuracy (Note1)	ΔV_{OUT}	$V_{IN}=V_{OUT}+0.1\text{V}$ to 6V $V_{OUT}\geq 2.5\text{V}$, $I_{OUT}=1\text{mA}$	-2	-	+2	%	
		$V_{IN}=2.6\text{V}$ to 6V $2.5\text{V} > V_{OUT}\geq 1.0\text{V}$, $I_{OUT}=1\text{mA}$	-3	-	+3		
Quiescent Current	I_Q	$I_{OUT}=0\text{mA}$, $V_{IN}=5\text{V}$	-	50	-	μA	
Dropout Voltage	V_{DROP}	$I_{OUT}=1.0\text{A}$	$V_{OUT}=1.20\text{V}$	-	1.40	1.7	V
			$V_{OUT}=1.50\text{V}$	-	1.10	1.4	
			$V_{OUT}=1.80\text{V}$	-	0.8	1.1	
			$V_{OUT}=2.50\text{V}$	-	0.57	0.7	
			$V_{OUT}=3.30\text{V}$	-	0.38	0.6	
Current Limit (Note 2)	I_{LIMIT}		1.3	1.5	-	A	
Short Circuit Current	I_{short}	Output Voltage $< 0.375 \cdot V_{OUT}$	-	600	-	mA	
Load Regulation (Note 3)	ΔV_{LOAD}	$I_{OUT}=10\text{m}\sim 1.2\text{A}$	$2.0\text{V} > V_{OUT}$	-	10	20	mV
			$2.0\text{V} \leq V_{OUT}$	-	0.5	1	%
Ripple Rejection	PSRR	$C_{IN}=2.2\mu\text{F}$, $C_{OUT}=2.2\mu\text{F}$, $I_{OUT}=10\text{mA}$	$F=120\text{Hz}$	-	65	-	dB
			$F=1\text{KHz}$	-	55	-	
Temperature Shutdown	T_S		-	140	-	$^{\circ}\text{C}$	
Temperature Shutdown Hysterisis	T_{SH}		-	30	-	$^{\circ}\text{C}$	

Note1. Minimum V_{IN} voltage is defined by output adds a dropout voltage.

Note2. Current limit is measured at constant junction temperature by using pulsed testing with a low ON time.

Note3. Regulation is measured at constant junction temperature by using pulsed testing with a low ON time.

❖ **APPLICATION CIRCUIT**

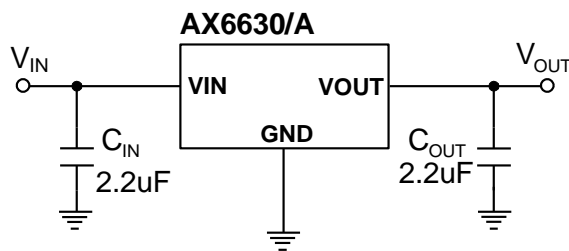

❖ **FUNCTION DESCRIPTIONS**

A minimum of $2.2\mu\text{F}$ capacitor must be connected from V_{OUT} to ground to insure stability. Typically a large storage capacitor is connected from V_{IN} to ground to ensure that the input voltage does not sag below the minimum dropout voltage during the load transient response. This pin must always be dropout voltage higher than V_{OUT} in order for the device to regulate properly.

❖ APPLICATION INFORMATION

Like any low-dropout regulator, the AX6630/A requires input and output decoupling capacitors. The device is specifically designed for portable applications requiring minimum board space and smallest components. These capacitors must be correctly selected for good performance (see Capacitor Characteristics Section). Please note that linear regulators with a low dropout voltage have high internal loop gains which require care in guarding against oscillation caused by insufficient decoupling capacitance.

Capacitor Selection

Normally, use a 2.2µF capacitor on the input and a 2.2µF capacitor on the output of the AX6630/A. Larger input capacitor values and lower ESR (X5R, X7R) provide better supply-noise rejection and transient response. A higher-value output capacitor (4.7µF) may be necessary if large, fast transients are anticipated and the device is located several inches from the power source.

Input-Output (Dropout) Voltage

A regulator's minimum input-to-output voltage differential (dropout voltage) determines the lowest usable supply voltage. In battery-powered systems, this determines the useful end-of-life battery voltage. Because the device uses a PMOS, its dropout voltage is a function of drain-to source on-resistance, $R_{DS(ON)}$, multiplied by the load current:

$$V_{DROPOUT} = V_{IN} - V_{OUT} = R_{DS(ON)} \times I_{OUT}$$

Current Limit and Short-Circuit Protection

The AX6630/A used a current sense-resistor to monitor the output current. A portion of the PMOS output transistor's current is mirrored to a resistor such that the voltage across this resistor is proportional to the output current. Once the output current exceeds limit threshold, AX6630/A would be protected with a limited output current. Further more, when the output is short to ground, the output current would be folded-back to a less limit.

Thermal Considerations

The AX6630/A series can deliver a current of up to 1.2A over the full operating junction temperature range. However, the maximum output current must be dated at higher ambient temperature to ensure the junction temperature does not exceed 125°C. With all possible conditions, the junction temperature must be within the range specified under operating conditions. Power dissipation can be calculated based on the output current and the voltage drop across regulator.

$$PD = (V_{IN} - V_{OUT}) I_{OUT}$$

The final operating junction temperature for any set of conditions can be estimated by the following thermal equation:

$$PD (MAX) = (T_{J(MAX)} - T_A) / \theta_{JA}$$

Where $T_{J(MAX)}$ is the maximum junction temperature of the die (125°C) and T_A is the maximum ambient temperature. The junction to ambient thermal resistance (θ_{JA}) for SOT223-3L package at recommended minimum footprint is 75°C/W (please refer Maximum rating table).

PCB Layout

An input capacitance of $\cong 2.2\mu\text{F}$ is required between the AX6630/A input pin and ground (the amount of the capacitance may be increased without limit), this capacitor must be located a distance of not more than 1cm from the input and return to a clean analog ground. Input capacitor can filter out the input voltage spike caused by the surge current due to the inductive effect of the package pin and the printed circuit board's routing wire. Otherwise, the actual voltage at the VIN pin may exceed the absolute maximum rating. The output capacitor also must be located a distance of not more than 1cm from output to a clean analog ground. Because it can filter out the output spike caused by the surge current due to the inductive effect of the package pin and the printed circuit board's routing wire.

❖ TYPICAL CHARACTERISTICS

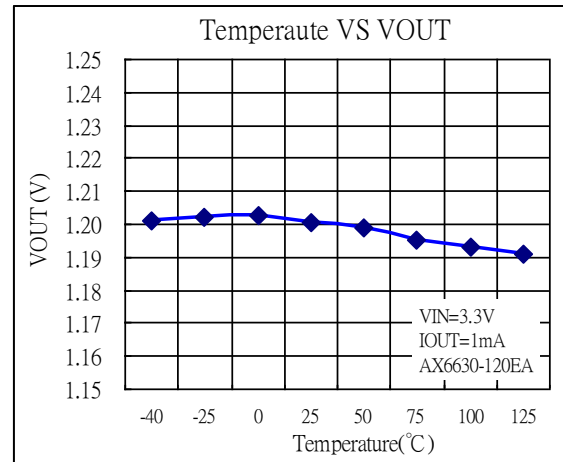
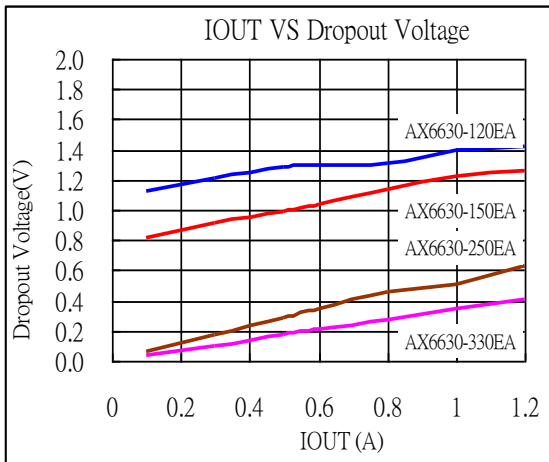
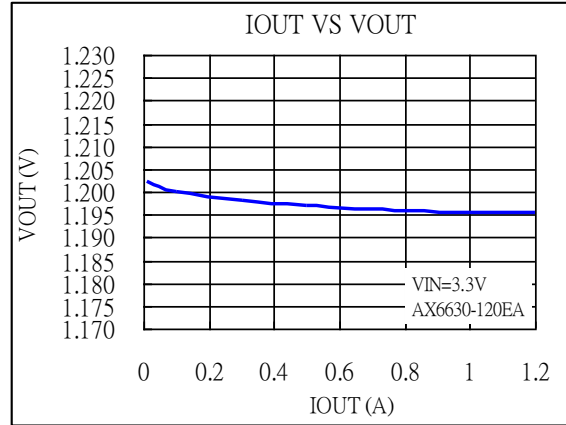
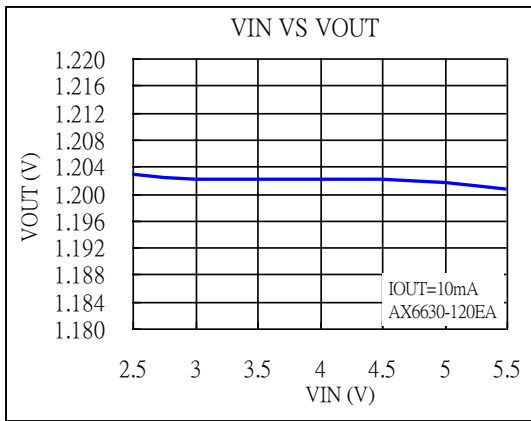

Power ON

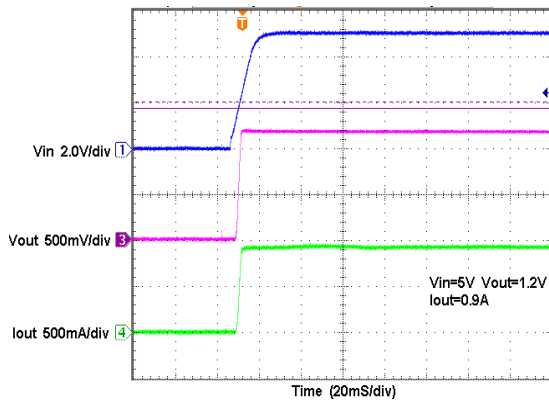

Load Transient

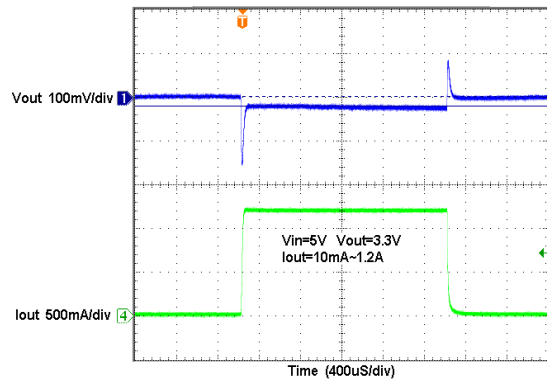

❖ **PACKAGE OUTLINES**

(1) SOT223-3L

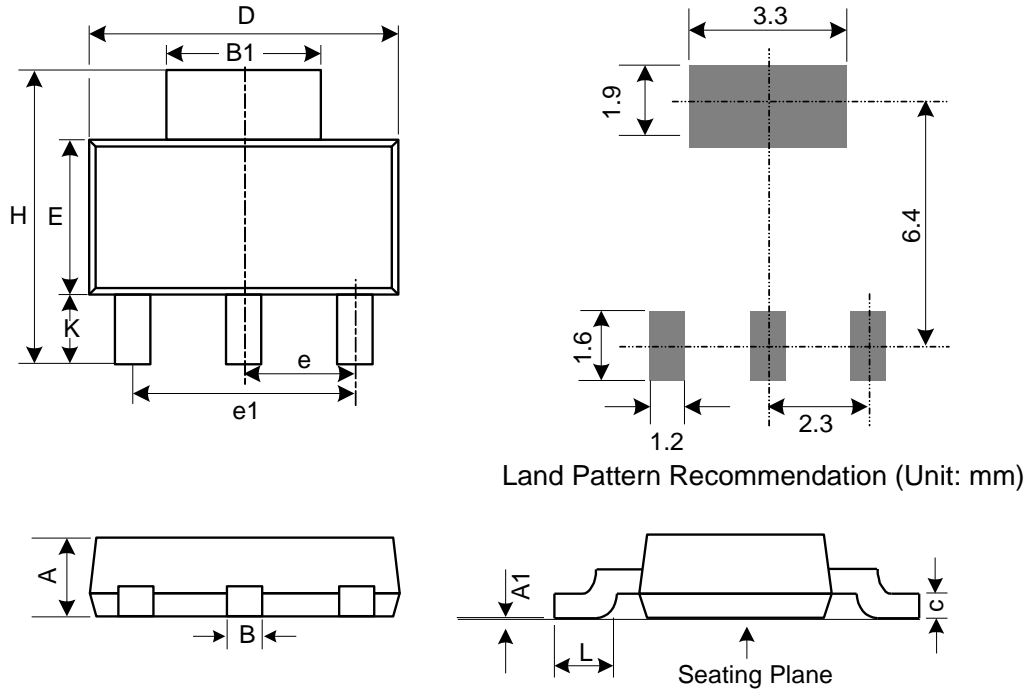

Symbol	Dimensions in Millimeters			Dimensions in Inches		
	Min.	Nom.	Max.	Min.	Nom.	Max.
A	-	-	1.8	-	-	0.071
A1	0.02	0.06	0.1	0.001	0.002	0.004
B	0.66	0.75	0.84	0.026	0.03	0.033
B1	2.9	3	3.1	0.114	0.118	0.122
C	0.23	0.315	0.35	0.009	0.012	0.014
D	6.3	6.5	6.7	0.248	0.256	0.264
E	3.3	3.5	3.7	0.13	0.138	0.146
H	6.7	7	7.3	0.264	0.278	0.287
L	0.75	-	-	0.03	-	-
K	1.5	1.75	2	0.059	0.069	0.079
e	2.3 Basic			0.091 Basic		
e1	4.6 Basic			0.181 Basic		

JEDEC outline: TO-261 AB

(2) TO252-3L

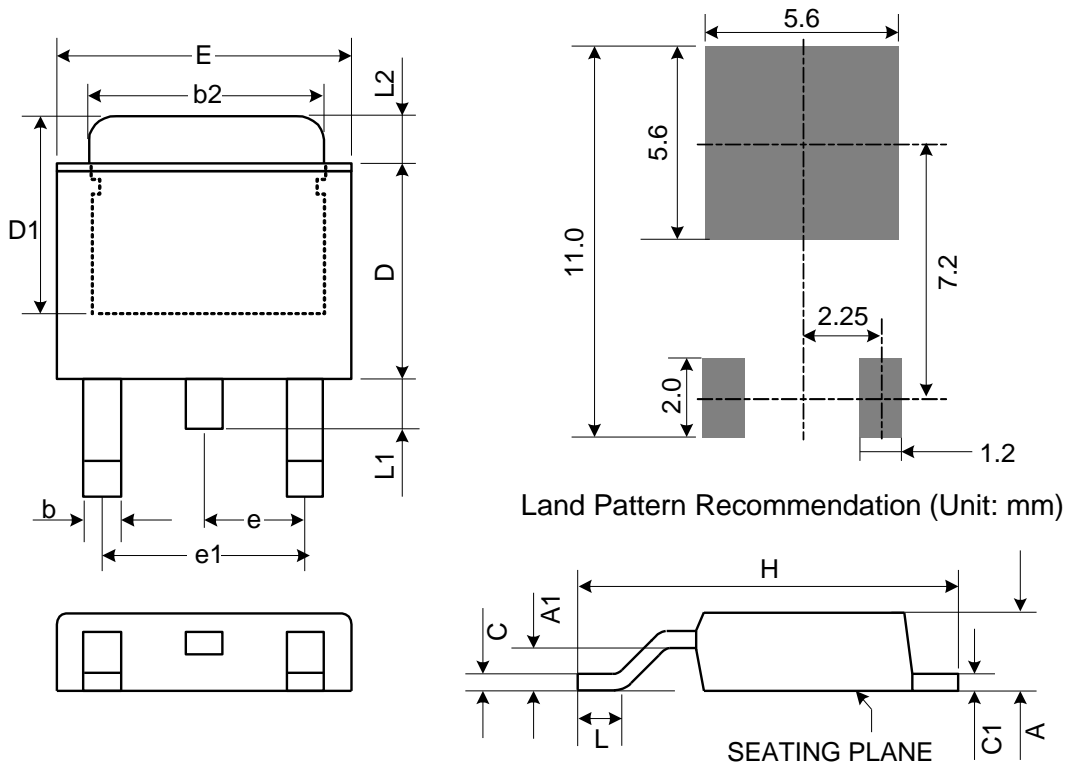

Symbol	Dimensions in Millimeters			Dimensions in Inches		
	Min.	Nom.	Max.	Min.	Nom.	Max.
A	2.18	2.29	2.39	0.086	0.09	0.094
A1	-	-	0.13	-	-	0.005
b	0.51	0.71	0.89	0.02	0.028	0.035
b2	4.95	5.21	5.46	0.195	0.205	0.215
C	0.46	0.53	0.61	0.018	0.021	0.024
C1	0.46	0.53	0.58	0.018	0.021	0.023
D	5.33	5.46	5.59	0.21	0.215	0.22
D1	4.57	-	-	0.18	-	-
E	6.35	6.55	6.73	0.25	0.258	0.265
e	2.29 BSC			0.090 BSC.		
e1	4.58 BSC			0.180 BSC.		
H	9.4	9.7	10.4	0.37	0.382	0.41
L	1.4	1.6	1.78	0.055	0.063	0.07
L1	-	-	1.02	-	-	0.04
L2	1.52	1.78	2.03	0.06	0.07	0.08

Mold flash shall not exceed 0.005inch per side
JEDEC outline: TO-252 AB

(3) TO263-2L

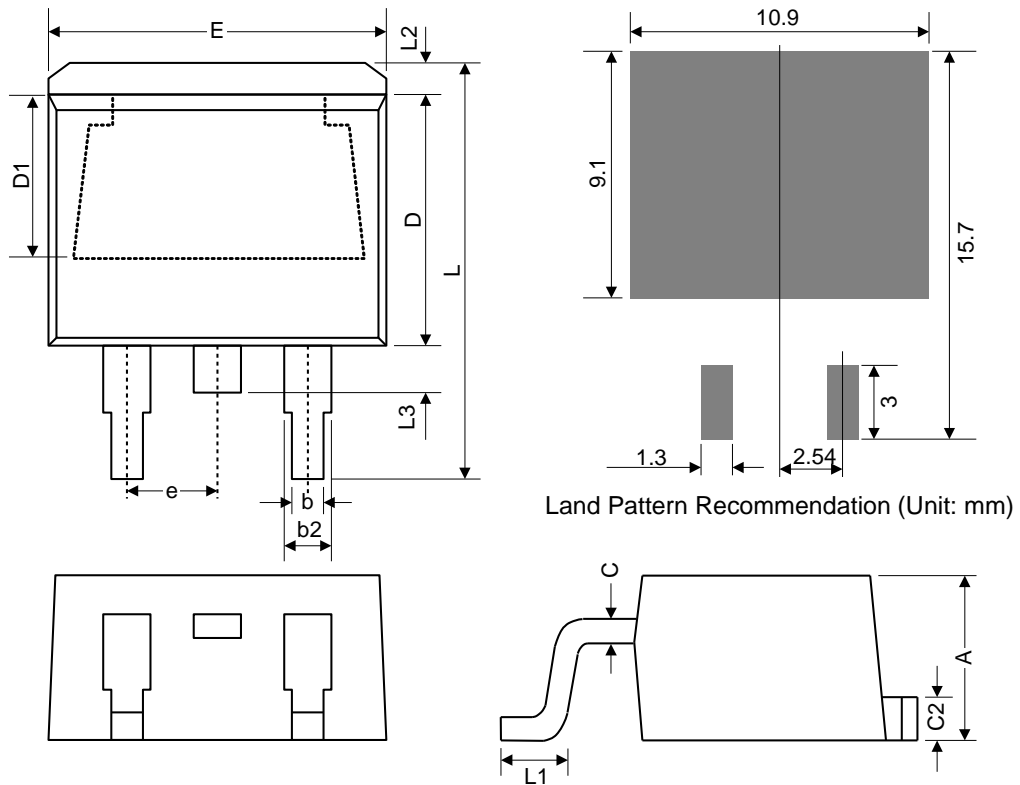

Symbol	Dimensions in Millimeters			Dimensions in Inches		
	Min.	Nom.	Max.	Min.	Nom.	Max.
A	4.06	4.45	4.83	0.16	0.175	0.19
b	0.51	0.76	0.99	0.02	0.03	0.039
b2	1.14	1.47	1.78	0.045	0.058	0.07
C	0.38	0.56	0.74	0.015	0.022	0.029
C2	1.14	1.4	1.65	0.045	0.055	0.065
D	8.38	9.02	9.65	0.33	0.355	0.38
D1	5.08	-	-	0.2	-	-
E	9.65	10.2	10.7	0.38	0.4	0.42
e	2.54 BSC			0.1 BSC		
L	14.6	15.2	15.9	0.575	0.6	0.625
L1	1.78	2.29	2.79	0.07	0.09	0.11
L2	-	-	1.68	-	-	0.066
L3	-	-	1.78	-	-	0.07

Mold flash shall not exceed 0.005inch per side
JEDEC outline: TO-263 AB

(4) SOT89-3L

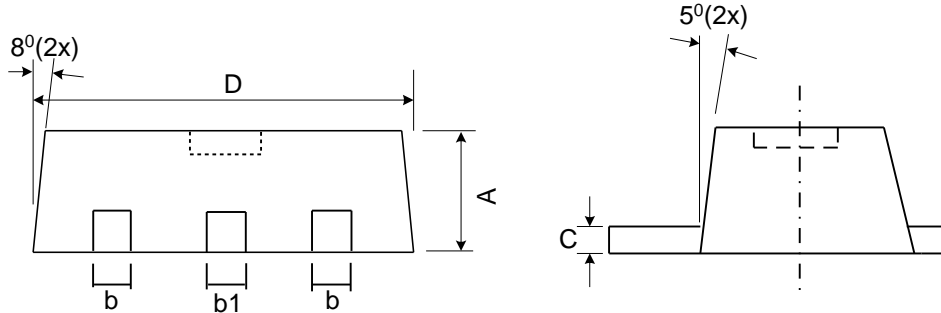
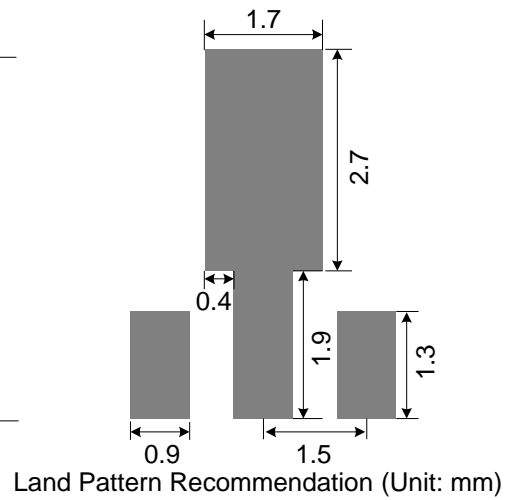
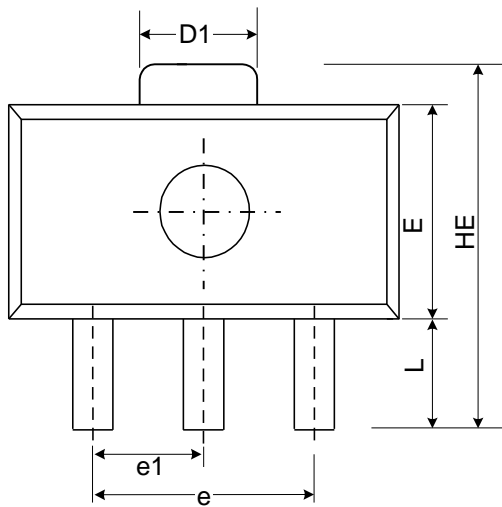

Symbol	Dimensions in Millimeters			Dimensions in Inches		
	Min.	Nom.	Max.	Min.	Nom.	Max.
A	1.40	1.50	1.60	0.055	0.059	0.063
b	0.36	0.42	0.48	0.014	0.017	0.019
b1	0.44	0.50	0.56	0.017	0.02	0.022
C	0.35	0.40	0.44	0.014	0.016	0.017
D	4.40	4.50	4.60	0.173	0.177	0.181
D1	1.35	1.59	1.83	0.053	0.063	0.072
e	3.0 BSC			0.118 BSC		
e1	1.5 BSC			0.059 BSC		
E	2.29	2.45	2.60	0.09	0.097	0.102
HE	3.94	4.10	4.25	0.155	0.161	0.167
L	0.80	1.00	1.20	0.031	0.04	0.047

JEDEC outline: TO-243 AB

❖ Carrier tape dimension

SOT-223-3L

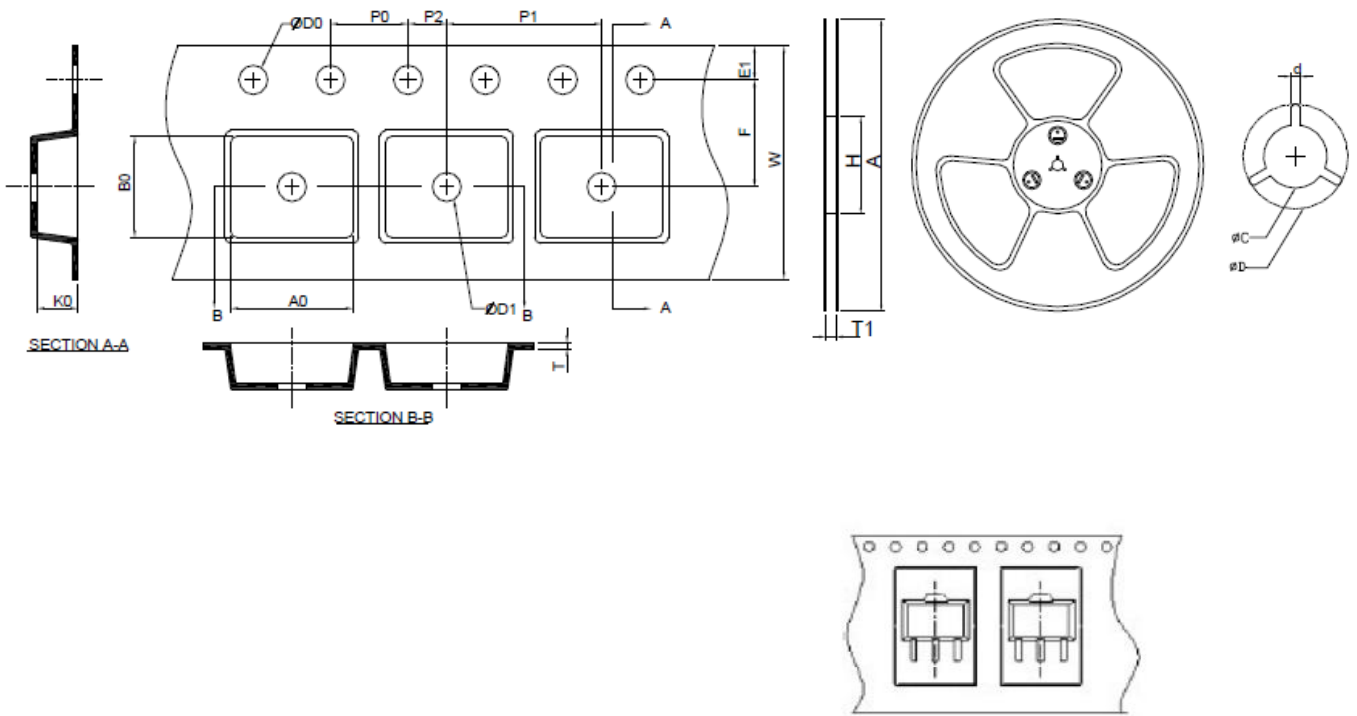

Application	A	H	T1	C	d	D	W	E1	F
SOT-223	320.0±2.00	50 MIN.	12.4+2.00 -0.00	13.0+0.50 -0.20	1.5 MIN.	20.2 MIN.	12.00±0.30	1.75±0.10	5.50±0.05
	P0	P1	P2	D0	D1	T	A0	B0	K0
	4.00±0.10	8.00±0.10	2.00±0.50	1.5+0.10 -0.00	1.5 MIN.	0.6+0.00 -0.40	6.90±0.20	7.50±0.20	2.10±0.20

TO-252-3L

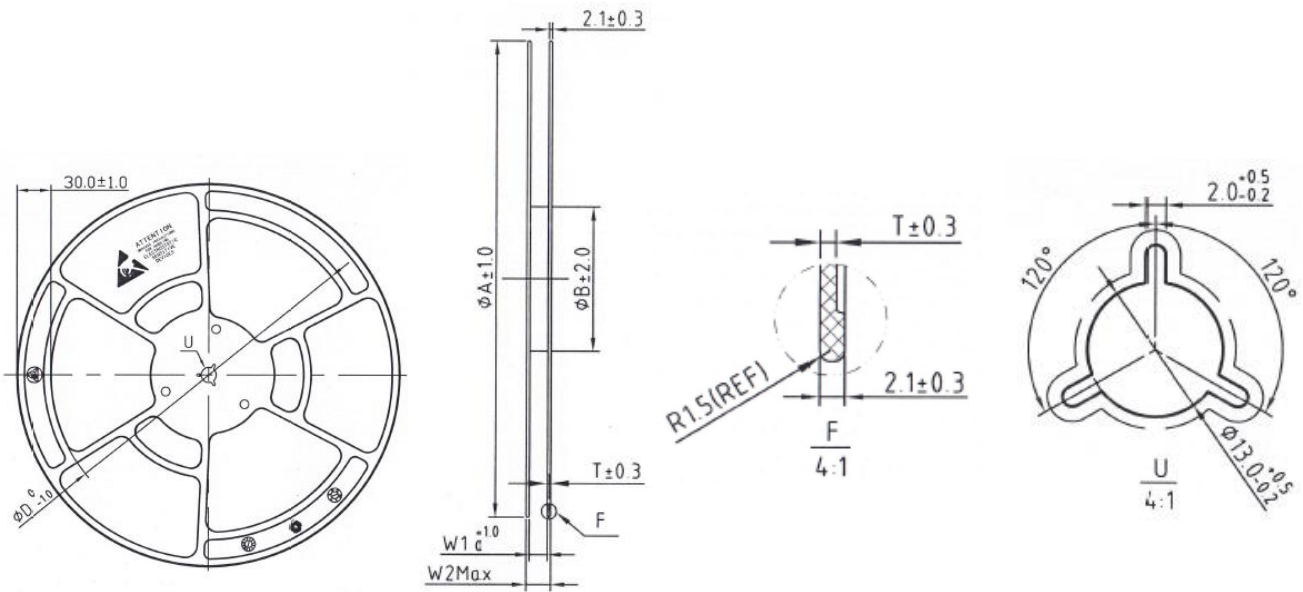

型號規格	適合載帶寬度	圓盤基本尺寸					
		A	B(內徑)	W1	W2Max	T	D
13" - 12X100	12 / 12.2	330	100	12.4	18.4	1.5	270
13" - 16X100	16			16.4	22.4		
13" - 24X100	24			24.4	30.4		

(mm)

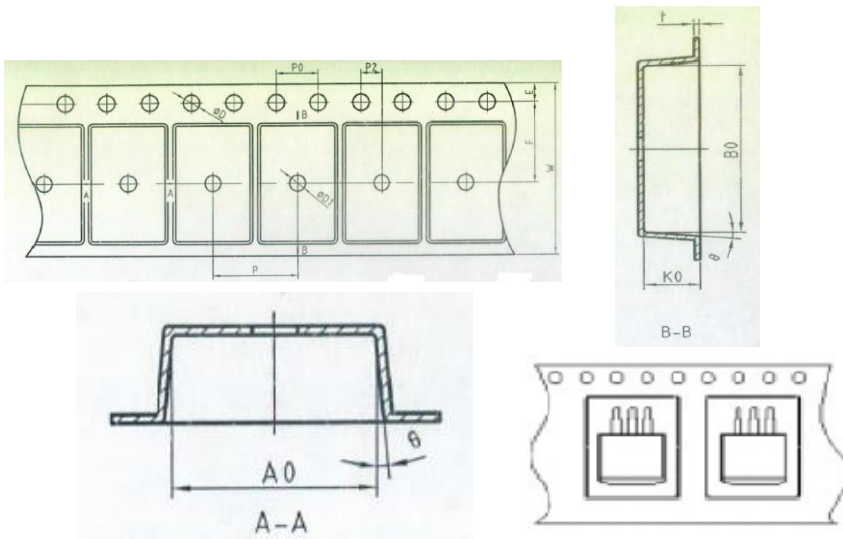

E	F	P ₂	D	D ₁	P ₀	10P ₀
1.75±0.10	7.50±0.10	2.00±0.10	1.50 ^{+0.1} ₀	1.50 ^{-0.25} ₀	4.00±0.10	40.0±0.20
W	P	A ₀	B ₀	K ₀	t	θ
16.00±0.10	8.00±0.10	6.90±0.10	10.50±0.10	2.65±0.10	0.30±0.02	5°TYP

(mm)

TO263-2L

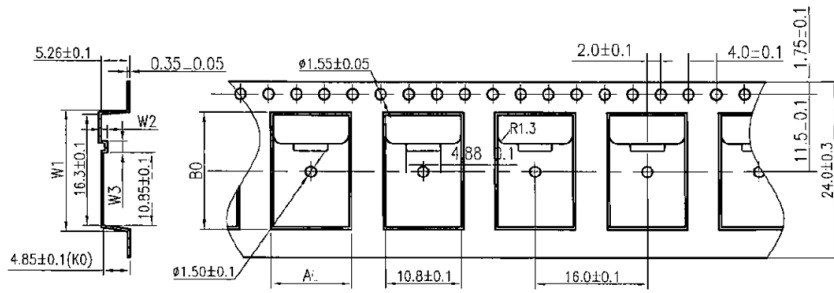

W1	17.2±0.1
W2	1.8±0.1
W3	0.85±0.1

(mm)

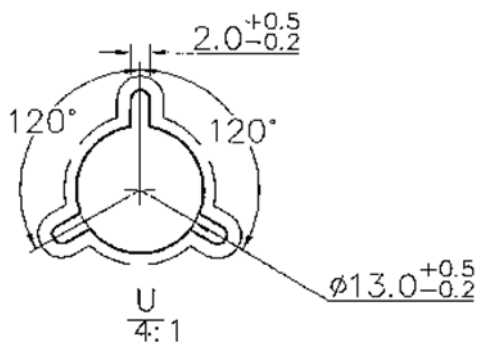
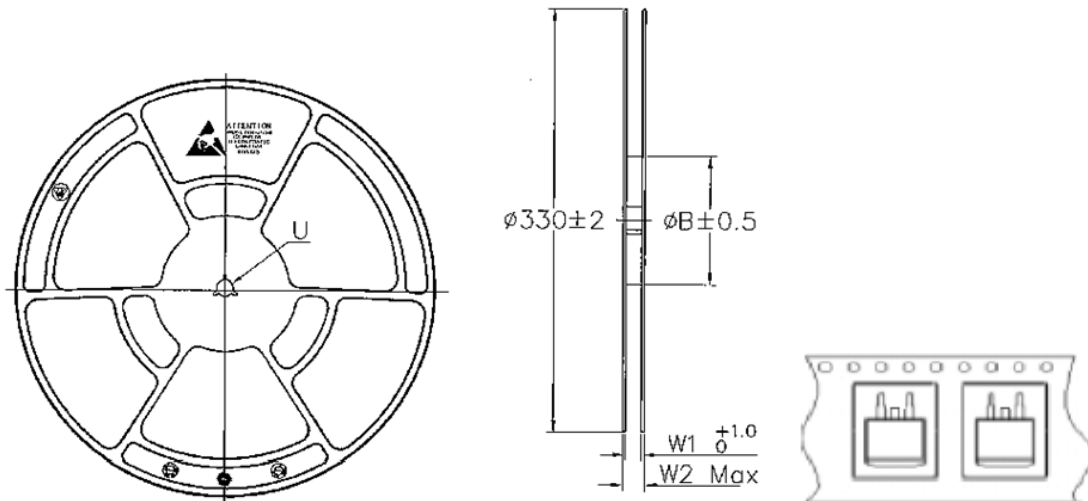

產品類別	載帶寬度	B(內徑)	W1	W2max
TO263	24	100	24.4	30.4

(mm)

SOT89-3L

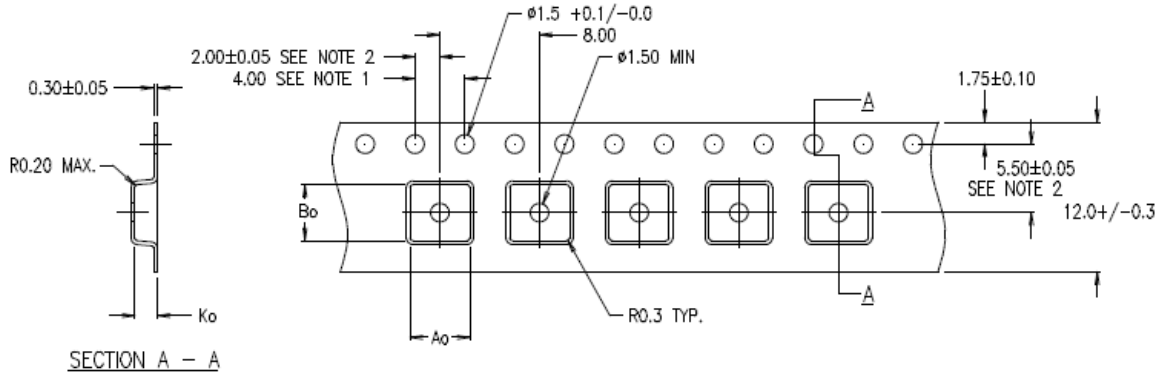

Ao = 4.80
Bo = 4.50
Ko = 1.80

