

2.0A Low Loss Power Switch With Flag

❖ GENERAL DESCRIPTION

AX8713/AX8723 is a low voltage, single NMOSFET high-side power switch, optimized for self-powered and bus-powered Universal serial bus (USB) application. AX8713/AX8723 equipped with a charge pump circuitry to drive the internal NMOSFET switch, the switch's low $R_{ds(on)}$ 70m Ω , meets USB voltage droop requirement and a flag output is available to indicate fault conditions to the local USB controller.

Additional features include soft-start to limit the inrush current during plug-in, thermal shutdown to prevent catastrophic switch failure from high-current loads, under voltage lockout (UVLO) to ensure that the device remains off unless there is a valid input voltage present. The maximum current is limited to typically 3.0A in dual ports in accordance with the USB power requirement. The low quiescent current as 35uA makes this device ideal for portable battery operated equipment.

AX8713/AX8723 is available in SOT-23-5L, SOP-8L and MSOP-8L packages requiring minimum board space and few peripheral components.

❖ FEATURES

- Wide Input Voltage Range: 2.5V to 5.5V
- Compliant to USB Specifications
- AX8713/AX8723 Enable Active Low/High
- Typical R_{dson}
70m Ω (SOT-23-5L)
- Typical 2.1V under voltage lockout
Output can be forced higher than input (Off-state)
- Low supply current
Less than 1uA at the off state
35uA at switch on state
- Guaranteed 2A continuous load current
- Open Drain Fault Flag Output
- Hot Plug-In Application(Soft start)
- Current Limiting Protection
- Thermal Shutdown Protection
- Reverse Current Flow Blocking (no body diode)
- RoHS and Halogen free compliance
- UL Approved-E353665
- TuV EN60950-1 Certification
- CB IEC60950-1 Certification

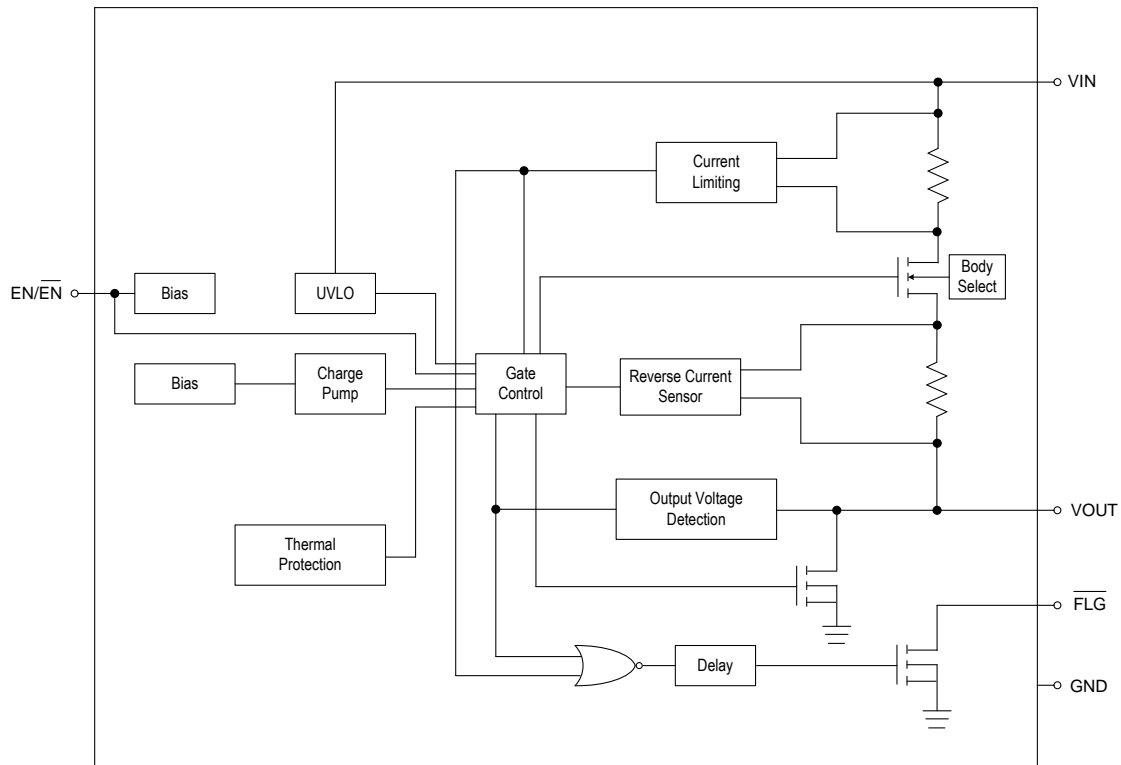
❖ BLOCK DIAGRAM

❖ PIN ASSIGNMENT

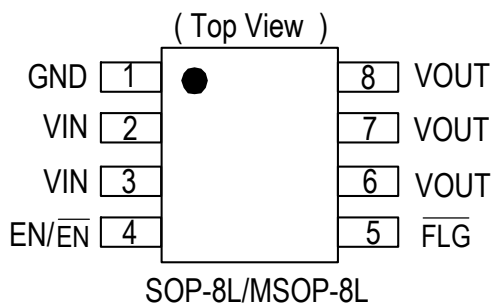
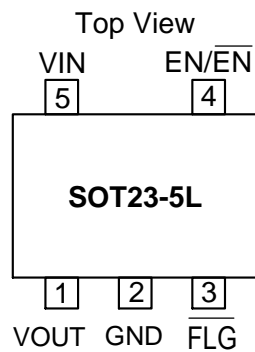
The pin assignment is given by:



Name	Pin No. SOT-23-5L	Pin No. SOP-8 /MSOP-8	Description
VOUT	1	6,7,8	Output Voltage.
GND	2	1	Ground.
FLG	3	5	Fault FLAG Output.
EN/EN	4	4	Chip Enable (Active High/Low).
VIN	5	2,3	Power Input Voltage.

❖ ELECTRICAL CHARACTERISTICS

 (V_{IN}=5V, C_{IN}=1uF, C_{OUT}=10uF per channel, T_A = 25°C, unless otherwise specified)

Characteristics		Symbol	Conditions	Min	Typ	Max	Units	
Input Voltage Range		V _{IN}		2.5	-	5.5	V	
Under Voltage Lockout		V _{UVLO}	V _{IN} Increase	1.7	2.1	2.4	V	
Under Voltage Hysteresis			V _{IN} Decrease	-	100	-	mV	
Input Leakage Current		I _{LEAK}	Disabled, OUT grounded		0.1	1	μA	
Output Leakage Current			Disabled, R _{LOAD} =0Ω	-	0.5	1	μA	
Reverse Leakage Current		I _{REV}	Disabled, V _{IN} = 0V, V _{OUT} = 5V, I _{REV} at V _{IN}		0.1	1	μA	
Switch On Resistance		R _{DSON}	V _{IN} =3.3V, I _{OUT} =0.5A	-	60	75	mΩ	
			V _{IN} =5.0V, I _{OUT} =0.5A	-	60	75		
Supply Current		I _Q	Switch On, V _{OUT} = OPEN	-	35	55	μA	
		I _{SHDN}	Switch Off, V _{OUT} = OPEN	-	0.1	1		
EN Threshold	AX8723	V _{IL}	Low Voltage	-	-	0.7	V	
		V _{IH}	High Voltage	1.3	-	-	V	
$\overline{\text{EN}}$ Threshold	AX8713	V _{IH}	High Voltage	-	-	0.7	V	
		V _{IL}	Low Voltage	1.3	-	-	V	
EN/ $\overline{\text{EN}}$ Input Current		I _{SINK}	V _{EN} / $\overline{\text{EN}}$ From 0V to 5V	-	0.01		μA	
Current Limit		I _{LIMIT}	V _{IN} = 5V, V _{OUT} = 4.5V	-40°C ≤ T _A ≤ 85°C	2.2	3.0	3.8	A
Short Circuit Fold back Current Hysteresis		I _{SHORT}	V _{OUT} =0V, Measured prior to the thermal shutdown	-	1.2	-	A	
Output Turn-on Rise Time		T _R	V _{IN} =3.3V, C _L =1μF, R _{load} =3Ω, V _{OUT} Rise From 10% to 90%	-	1.6	-	ms	
			V _{IN} =5.0V, C _L =1μF, R _{load} =5Ω, V _{OUT} Rise From 10% to 90%	-	3.0	-	ms	
Output Turn-on Delay Time		T _{D(ON)}	C _L =1μF, R _{load} =10Ω, EN 10% ($\overline{\text{EN}}$ 90%) to V _{OUT} 10%	-	50	-	us	
Output Turn-off Fall Time		T _F	C _L =1μF, R _{load} =10Ω, V _{OUT} Fall From 90% to 10%	-	20	-	us	
Output Turn-off Delay Time		T _{D(OFF)}	C _L =1μF, R _{load} =10Ω, EN 90% ($\overline{\text{EN}}$ 10%) to V _{OUT} 90%	-	10	-	us	
Reverse Current Limit		I _{RLIMIT}	V _{IN} = 5V, V _{OUT} = 5.5V -40°C ≤ T _A ≤ 85°C		500		mA	
Reverse Over Voltage Protect		V _{ROVP}	V _{OUT} - V _{IN}		150		mV	
Reverse Protect Delay Time		T _{PD}			5		mS	

❖ ELECTRICAL CHARACTERISTICS (CONTINUOUS)

($V_{IN}=5V$, $C_{IN}=1\mu F$, $C_{OUT}=10\mu F$, $T_A = 25^\circ C$, unless otherwise specified)

Characteristics	Symbol	Conditions	Min	Typ	Max	Units
FLG Output Resistance	R_{FLG}	$I_{SINK}=1mA$	-	20	40	Ω
FLG Off Current		$V_{\overline{FLG}} = 5V$	-	0.01	1	μA
FLG DELAY TIME	T_{Blank}	From Fault Condition to \overline{FLG} assertion	5	15	20	ms
Output Shutdown Discharge Resistance		Disabled	-	100	150	Ω
Thermal Shutdown Threshold	T_{SD}	Enabled	-	150	-	$^\circ C$
Thermal Shutdown Hysteresis	T_{HYS}	$V_{OUT} = 0V$	-	20	-	$^\circ C$

Note 1: Thermal Resistance is specified with approximately 1 square of 1 oz copper.

Note 2: 100% production test at $+25^\circ C$. Specifications over the temperature range are guaranteed by design and characterization. The device is not guaranteed to function outside its operating conditions.

❖ APPLICATION INFORMATION

The AX8713/8723 is a single N-MOSFET high-side power switch with enable input, optimized for self-powered and bus-powered Universal Serial Bus (USB) applications. The AX8713/AX8723 series are equipped with a charge pump circuitry to drive the internal N-MOSFET switch; The switch's low $R_{ds(on)}$, 70m Ω meets USB voltage drop requirements and a flag output is available to indicate fault conditions to the local USB controller.

Input and Output

V_{IN} (Input) is the power source connection to the internal circuitry and the drain of the N-MOSFET. V_{OUT} (Output) is the source of the N-MOSFET. In a typical application, current flows through the switch from V_{IN} to V_{OUT} toward the load. If V_{OUT} is greater than V_{IN} , current will flow from V_{OUT} to V_{IN} since the MOSFET is bidirectional when on. Unlike a normal MOSFET, there is no a parasitic body diode between drain and source of the MOSFET, the AX8713/8723 prevents reverse current flow if V_{OUT} being externally forced to a higher voltage than V_{IN} when the output disabled ($V_{EN} < 0.8V$ or $V_{\overline{EN}} > 2V$).

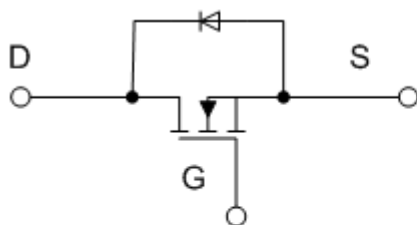

Normal MOSFET

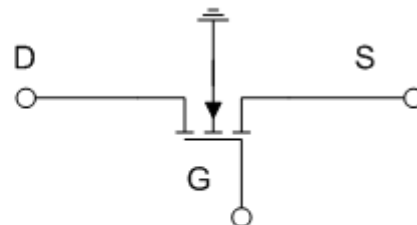

AX8713

Enable

The switch will be disabled when the EN pin is low or $\overline{\text{EN}}$ is high. During this condition, the internal circuitry and MOSFET are all turned off and the supply current reduces to 0.1uA typically. Floating the $\text{EN}/\overline{\text{EN}}$ may cause unpredictable operation. EN should not be allowed to be negative to GND. The $\text{EN}/\overline{\text{EN}}$ pin may be directly tied to VIN (GND) to keep the part on.

UVLO

Under-Voltage Lockout (UVLO) prevents the power MOSFET from turning on until the input voltage is up to approximately 2.1V. If the input voltage drops below about 2.0V, UVLO turns off the power MOSFET switch and $\overline{\text{FLG}}$ will be asserted accordingly. Under voltage protection is function when the part is enabled.

Soft Start for Hot Plug Application

In order to eliminate the upstream voltage droop caused by the large inrush current during the hot plug events, the soft start feature effectively isolates the power source from extremely large load capacitor, satisfying the USB voltage droop requirement.

Fault Flag

The AX8713/AX8723 series provides a $\overline{\text{FLG}}$ signal pin which is an N-Channel open drain MOSFET output. This open drain output goes low when $V_{\text{OUT}} < V_{\text{IN}} - 1\text{V}$, current limit or the die temperature exceeds 150°C approximately. The $\overline{\text{FLG}}$ output is typically about 200mV when sinking a 10mA load. A 100K pull up resistor is required at the $\overline{\text{FLG}}$ pin. $\overline{\text{FLG}}$ Pin will be asserted at the over-current condition after the flag response delay time T_{D} . This ensures that $\overline{\text{FLG}}$ is asserted only at the valid over-current conditions and error reporting is eliminated.

Current Limiting and Short-Circuit Protection

The current limit circuitry prevents damage to the MOSFET switch and the hub downstream port but can deliver load current up to the current limit threshold of typically 3.0A through the switch of AX8713/AX8723. When a heavy load or short circuit is applied to an enabled switch, a large transient current may flow until the current limit circuitry responds. Once this current limit threshold is exceeded the device enters constant current mode until the thermal shutdown occurs or the fault is removed.

Thermal Shutdown

Thermal shutdown is employed to protect the device from damage if the die temperature exceeds approximately 150°C. If enabled, the switch automatically restarts when the die temperature falls 20°C. The output and $\overline{\text{FLG}}$ signal will continue to cycle on and off until the device is disabled or the fault is removed.

Reverse Current Limit & Reverse over Voltage Protect

The AX8713/23 series provides the reverse current limit(Rlimit) function to clamp the current through MOSFET switch from output side to the input side when output(V_{out}) is higher than input(V_{IN}) which is caused by external wrong connects. If $0V < (V_{out} - V_{in}) < 150mV$ (typically), the reverse current through the MOSFET switch could be limited to 500mA(typically) until the wrong connects be removed or $(V_{out} - V_{in}) > 150mV$.

In addition to Rlimit, the reverse over voltage protect(Rovp) function also be added in the AX8713/23 series, this function cut off any path from output side to input side and automatic recovery when fault issue be removed.

Input capacitor

A 1 μ F low ESR ceramic capacitor from V_{IN} to GND, located at the device is strongly recommended to prevent the input voltage drooping during hot-plug events. However, higher capacitor values will further reduce the voltage droop at the input. Furthermore, without the bypass capacitor, an output short may cause sufficient ringing on the input (from source lead inductance) to destroy the internal control circuitry. The input transient must not exceed 6.5V of the absolute maximum supply voltage even for a short duration.

Output capacitor

A low ESR 150 μ F aluminum electrolytic or tantalum between V_{OUT} and GND is strongly recommended to meet the 330mV maximum droop requirement in the hub VBUS (Per USB 2.0, output ports must have a minimum 120 μ F of low ESR bulk capacitor per hub). Standard bypass methods should be used to minimize inductance and resistance between the bypass capacitor and the downstream connector to reduce EMI and decouple voltage droop caused when downstream cables are hot insertion transients. Ferrite beads in series with VBUS, the ground line and the 0.1 μ F bypass capacitors at the power connector pins are recommended for EMI and ESD protection. The bypass capacitor itself should have a low dissipation factor to allow decoupling at higher frequencies.

PCB Layout Guide

For best performance of the AX8713/AX8723 series, the following guidelines must be strictly followed:

1. Input and output capacitors should be placed close to the IC and connected to ground plane to reduce noise coupling.
2. The GND should be connected to a strong ground plane for heat sink.
3. Keep the main current traces as possible as short and wide.

❖ APPLICATION CIRCUIT

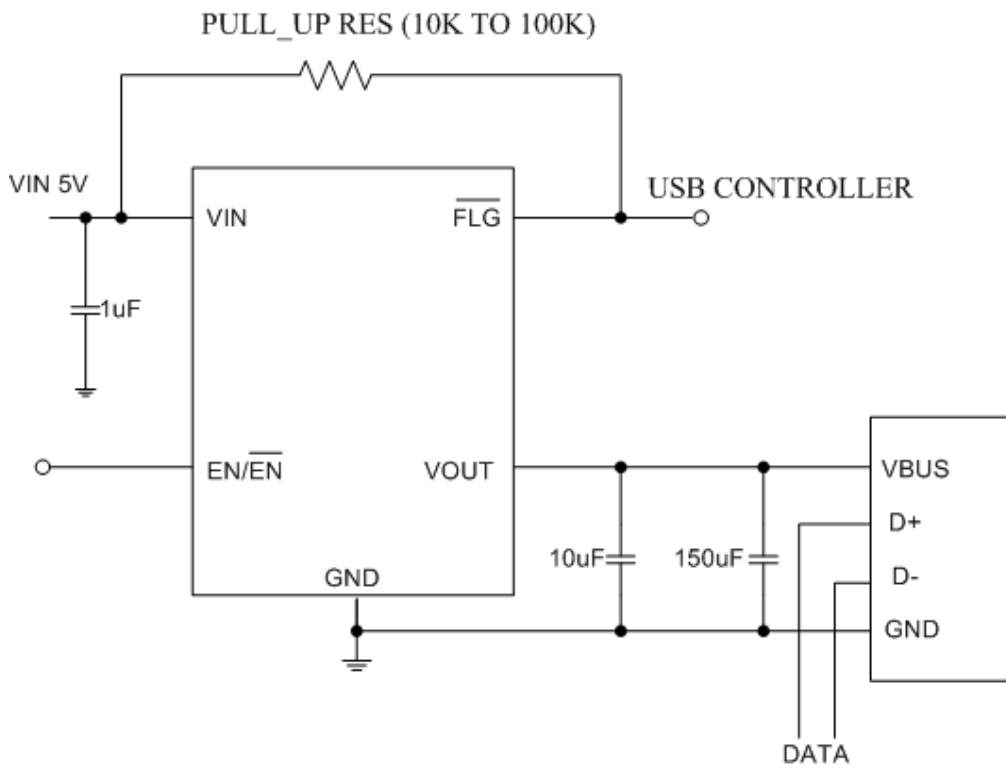

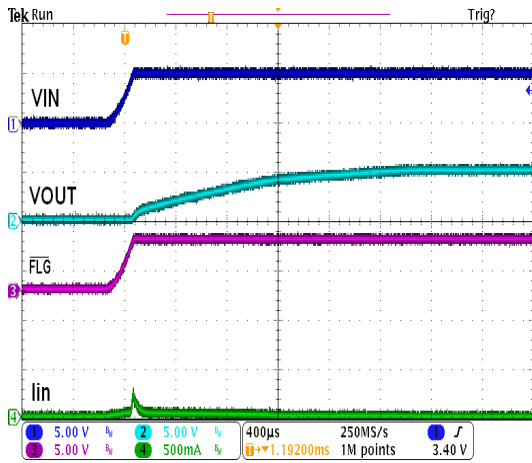
❖ TYPICAL CHARACTERISTICS

No load power on

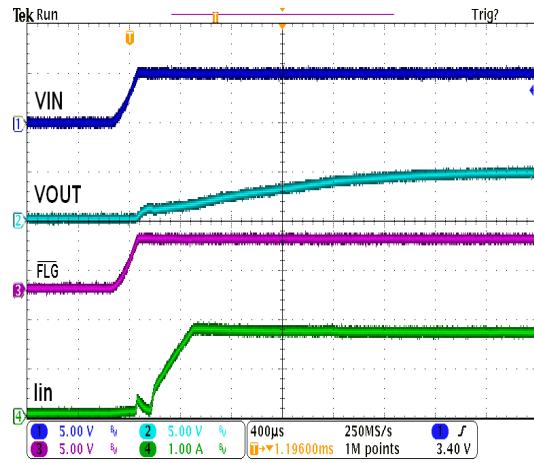

1.7A load power on

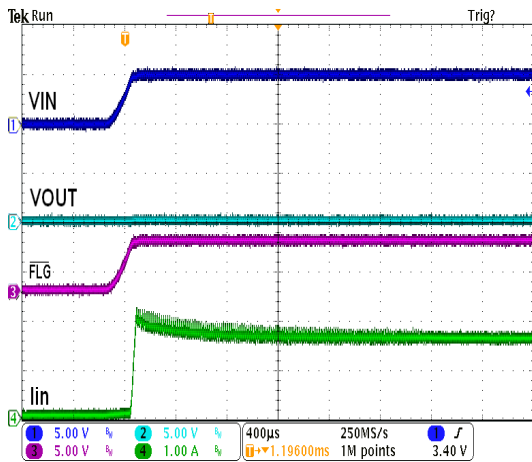

Output short circuit power on

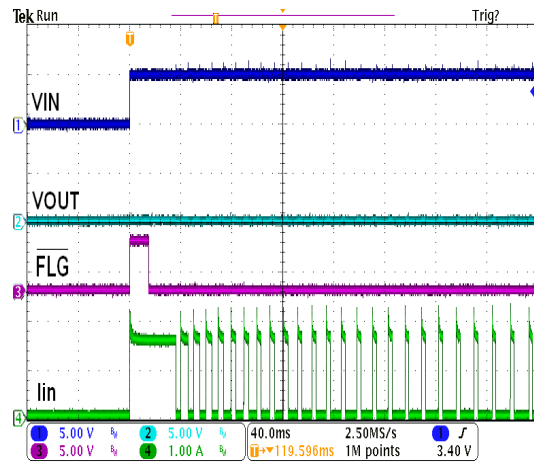

output short circuit & over temperature protection

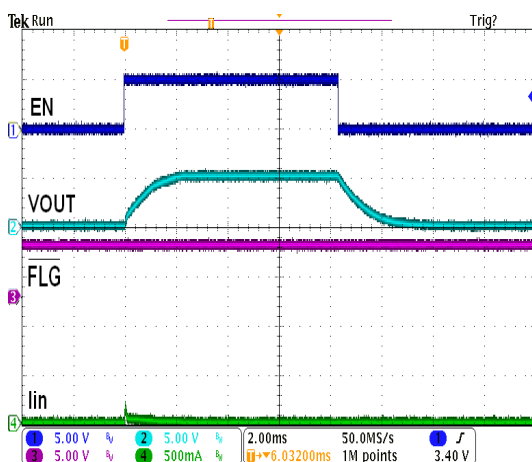

No load enable on/off

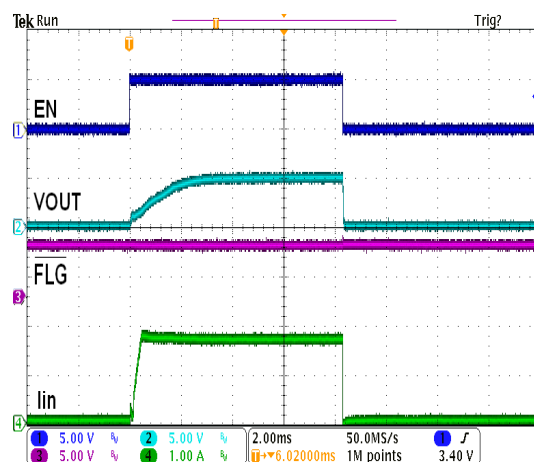

1.7A load enable on/off

❖ TYPICAL CHARACTERISTICS (CONTINUOUS)

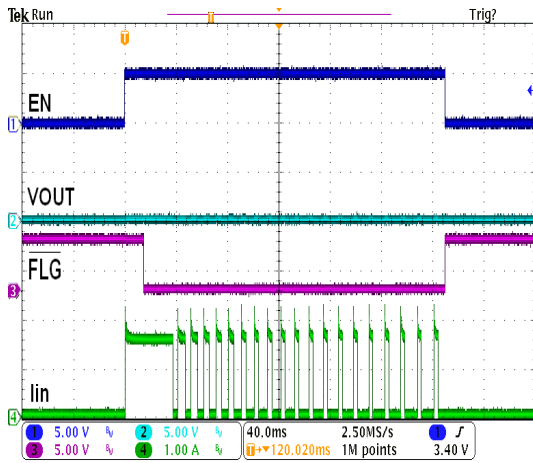

Output short circuit enable on/off

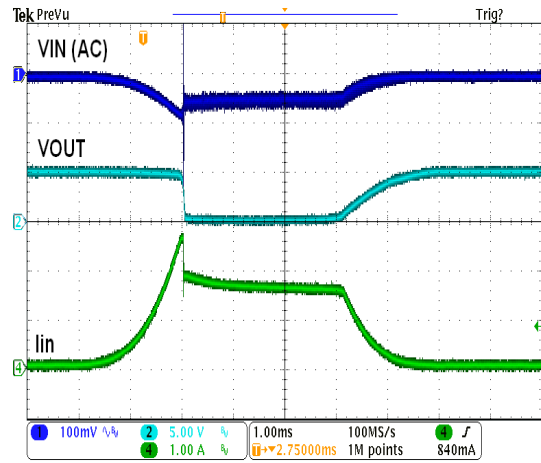

over current & short circuit protection

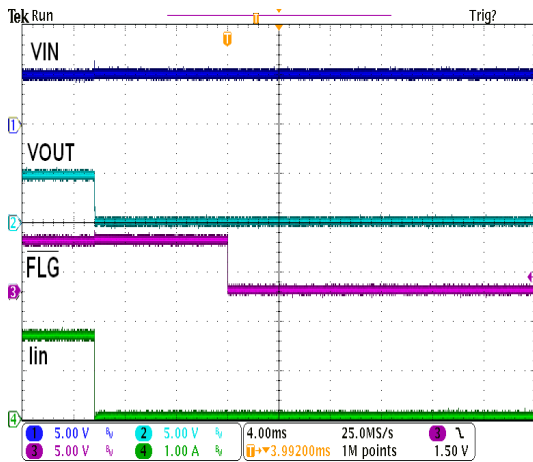

1.7A load thermal shutdown

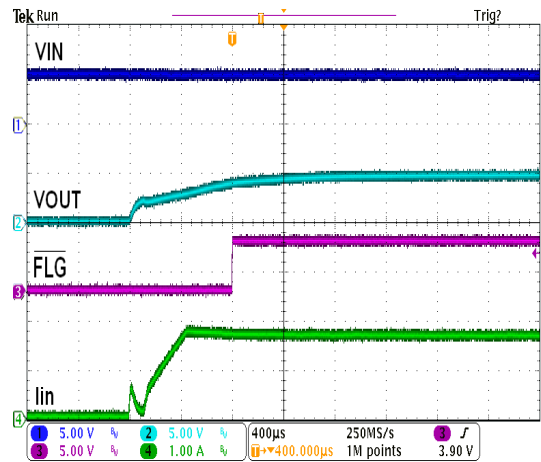

1.7A load thermal shutdown release

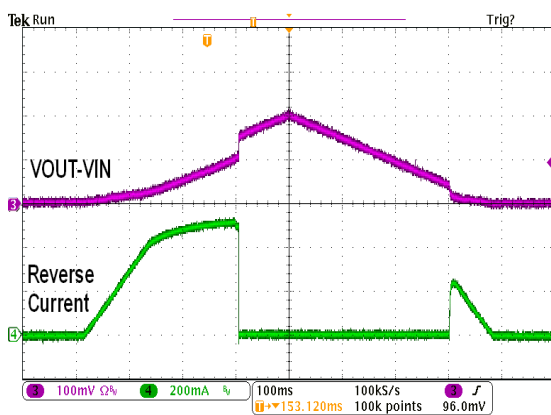

Reverse current protection

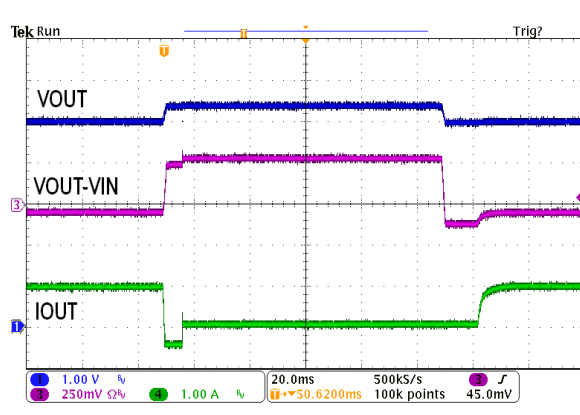

Reverse current protection

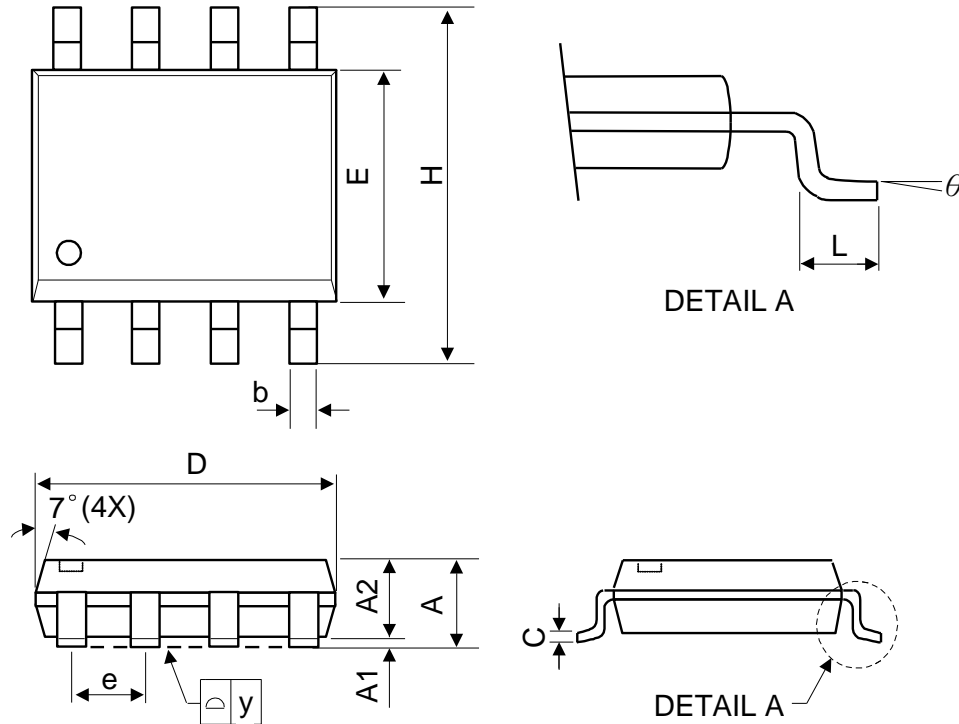
❖ PACKAGE OUTLINES
(1) SOP-8L

Symbol	Dimensions in Millimeters			Dimensions in Inches		
	Min.	Nom.	Max.	Min.	Nom.	Max.
A	-	-	1.75	-	-	0.069
A1	0.1	-	0.25	0.04	-	0.1
A2	1.25	-	-	0.049	-	-
C	0.1	0.2	0.25	0.0075	0.008	0.01
D	4.7	4.9	5.1	0.185	0.193	0.2
E	3.7	3.9	4.1	0.146	0.154	0.161
H	5.8	6	6.2	0.228	0.236	0.244
L	0.4	-	1.27	0.015	-	0.05
b	0.31	0.41	0.51	0.012	0.016	0.02
e	1.27 BSC			0.050 BSC		
y	-	-	0.1	-	-	0.004
θ	0°	-	8°	0°	-	8°

Mold flash shall not exceed 0.25mm per side

JEDEC outline: MS-012 AA

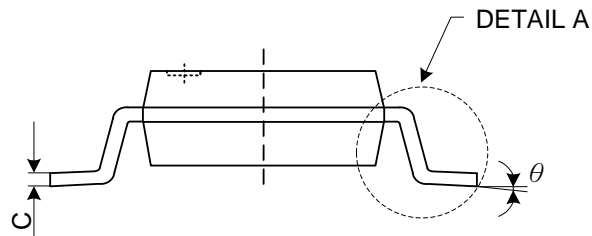
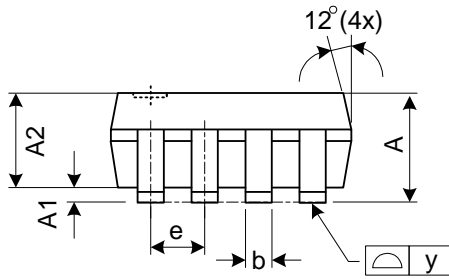
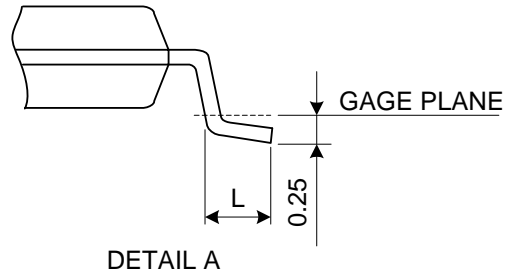
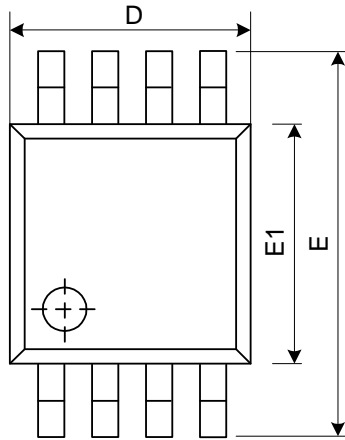
(2) MSOP-8L

Symbol	Dimensions in Millimeters			Dimensions in Inches		
	Min.	Nom.	Max.	Min.	Nom.	Max.
A	-	-	1.10	-	-	0.043
A1	0.00	0.08	0.15	0.000	0.003	0.006
A2	0.75	0.85	0.95	0.030	0.033	0.037
b	0.22	0.30	0.38	0.009	0.012	0.015
C	0.08	0.15	0.23	0.003	0.006	0.009
D	2.90	3.00	3.10	0.114	0.118	0.122
E	4.80	4.90	5.00	0.189	0.193	0.197
E1	2.90	3.00	3.10	0.114	0.118	0.122
e	0.65 BSC			0.026 BSC		
L	0.40	0.60	0.80	0.016	0.024	0.031
y	-	-	0.1	-	-	0.004
θ	0°	4°	8°	0°	4°	8°

JEDEC outline: MO-187 AA

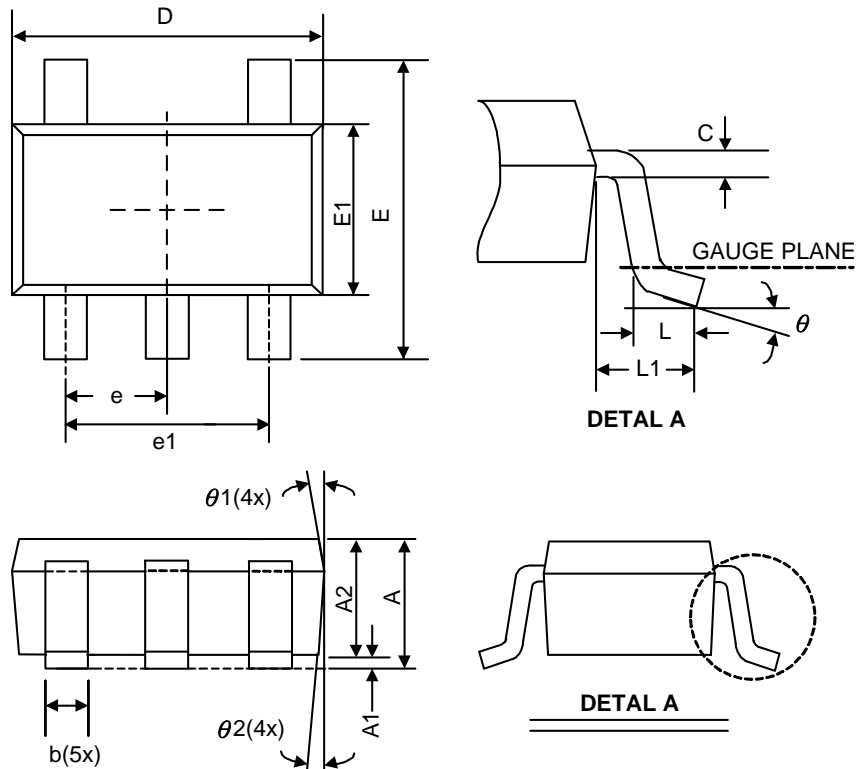
(3) SOT-23-5L

Symbol	Dimensions in Millimeters			Dimensions in Inches		
	Min.	Nom.	Max.	Min.	Nom.	Max.
A	-	-	1.45	-	-	0.057
A1	0	0.08	0.15	0	0.003	0.006
A2	0.9	1.1	1.3	0.035	0.043	0.051
b	0.3	0.4	0.5	0.012	0.016	0.02
C	0.08	0.15	0.22	0.003	0.006	0.009
D	2.7	2.9	3.1	0.106	0.114	0.122
E1	1.4	1.6	1.8	0.055	0.063	0.071
E	2.6	2.8	3	0.102	0.11	0.118
L	0.3	0.45	0.6	0.012	0.018	0.024
L1	0.5	0.6	0.7	0.02	0.024	0.028
e1	1.9 BSC			0.075 BSC		
e	0.95 BSC			0.037 BSC		
theta	0°	4°	8°	0°	4°	8°
theta 1	5°	10°	15°	5°	10°	15°
theta 2	5°	10°	15°	5°	10°	15°

JEDEC outline: MO-178 AA

❖ Carrier tape dimension

Carrier tape dimension(SOP-8L)

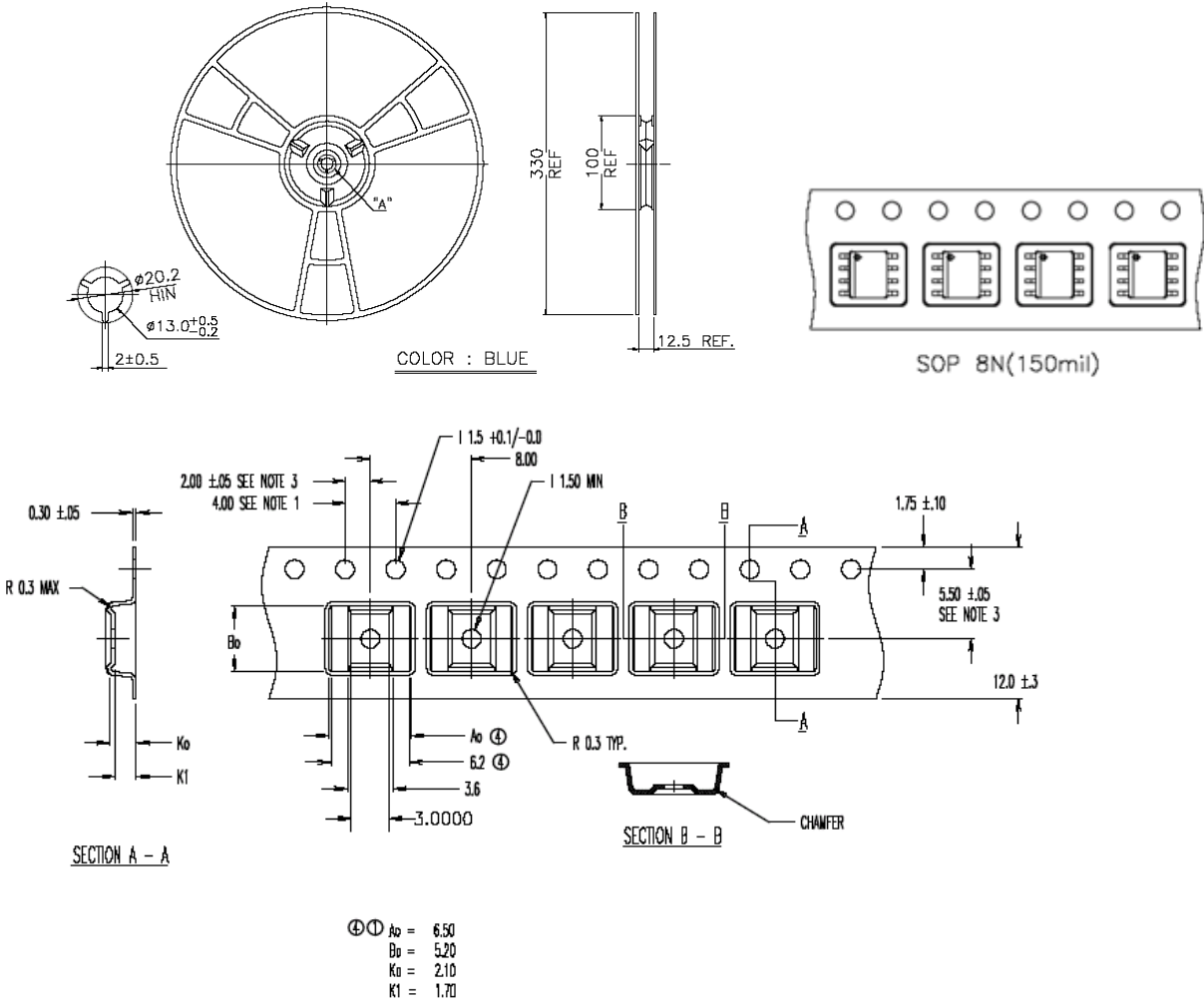

Carrier tape dimension(MSOP-8L)

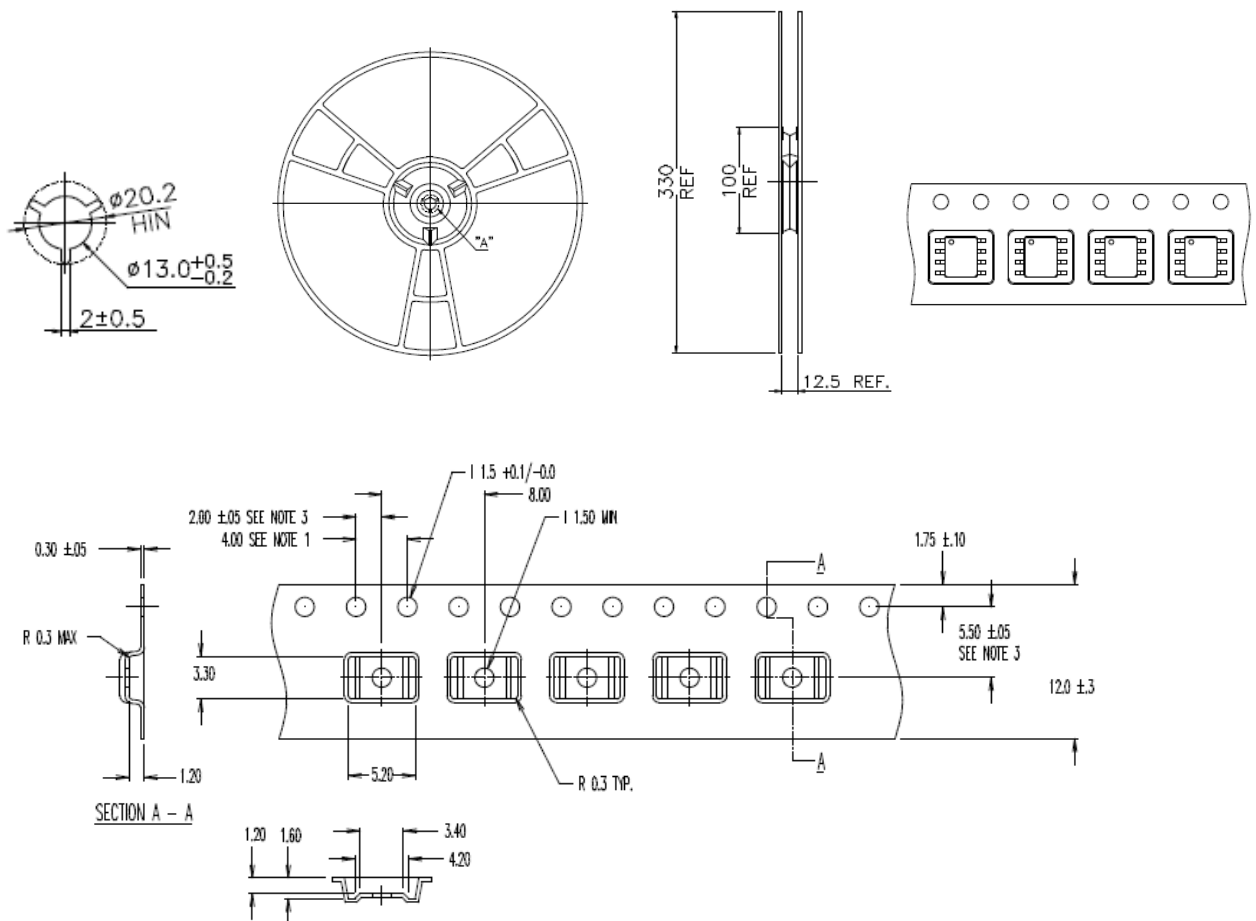

Carrier tape dimension(SOT-23-5L)

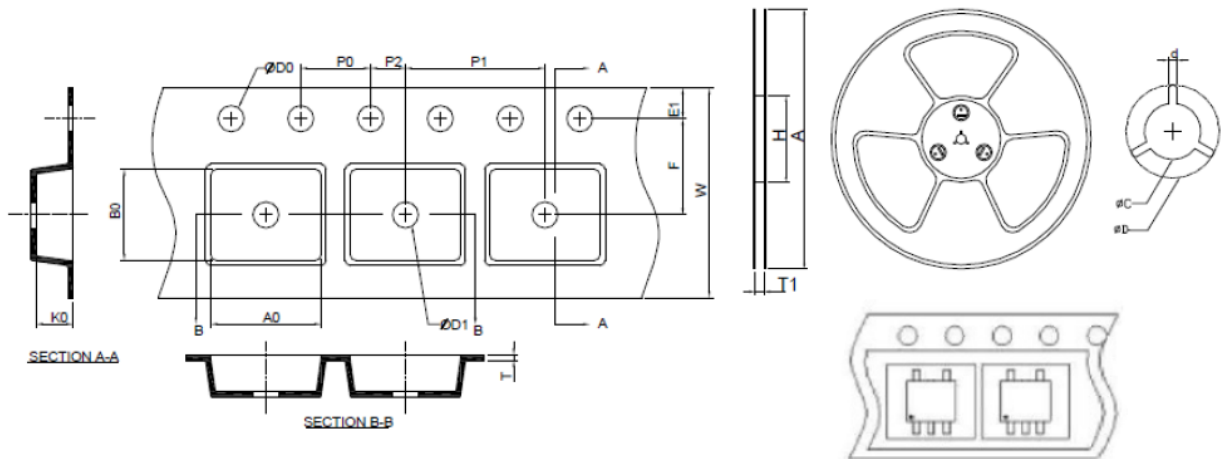

A	H	T1	C	d	D	W	E1	F
178.0±2.00	50 MIN.	8.4+2.00 -0.00	13.0+0.50 -0.20	1.5 MIN.	20.2 MIN.	8.0±0.30	1.75±0.10	3.5±0.05
P0	P1	P2	D0	D1	T	A0	B0	K0
4.0±0.10	4.0±0.10	2.0±0.05	1.5+0.10 -0.00	1.0 MIN.	0.6+0.00 -0.40	3.20±0.20	3.10±0.20	1.50±0.20

(mm)