

## 1.2V Output 1A LOW Dropout

### Linear Regulator

#### ❖ GENERAL DESCRIPTION

AX1212A is a low dropout positive 1.2V output regulator with minimum of 1A output current capability. The product is specifically designed to provide well-regulated supply for low voltage IC applications. AX1212A is also well suited for other applications such as VGA cards. AX1212A is guaranteed to have lower than 1.5V dropout at full load current making it ideal to provide well-regulated outputs of 1.2V with 2.6V to 12V input supply.

#### ❖ FEATURES

- Fixed 1.2V  $\pm$  2% output voltage
- 1.5V maximum dropout at full load current
- Low-ESR Ceramic Capacitor (MLCC) Required for Stability
- Fast transient response
- Output current limiting
- Built-in thermal shutdown
- Good noise rejection
- Pb-Free Packages: SOT223, TO252
- RoHS and Halogen free compliance.

#### ❖ BLOCK DIAGRAM

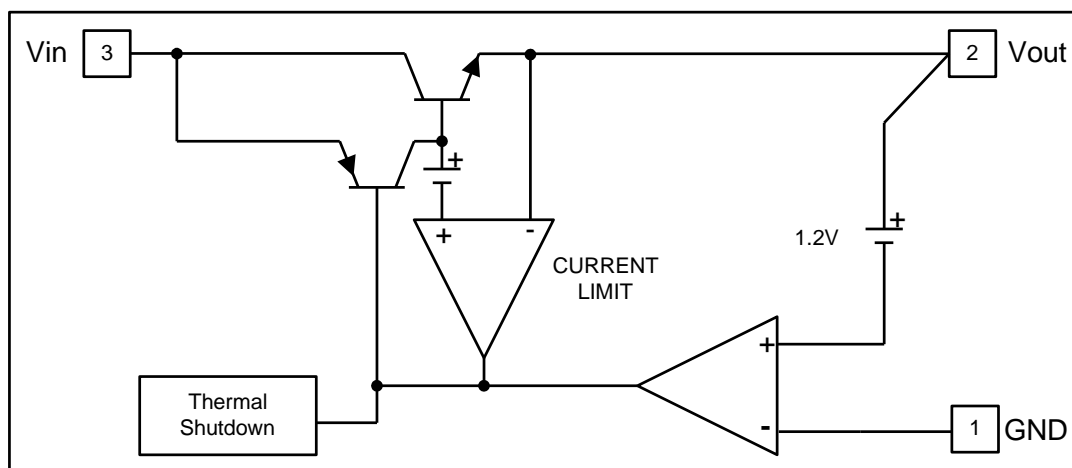

❖ **PIN ASSIGNMENT**

The packages of AX1212A are SOT223-3L and TO252-3L; the pin assignment is given by:

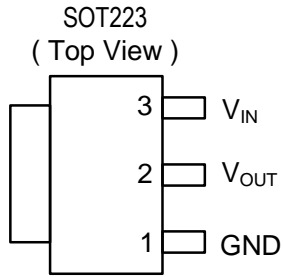

Tab is Vout

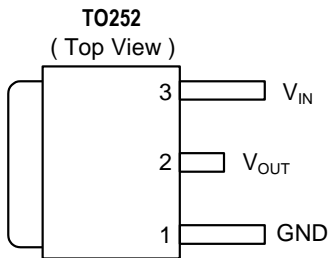

Tab is Vout

Name	Description
GND	A resistor divider from this pin to the $V_{OUT}$ pin and ground sets the output voltage. (Ground only for Fixed-Mode)
$V_{OUT}$	The output of the regulator. A minimum of 4.7uF MLCC capacitor must be connected from this pin to ground to insure stability.
$V_{IN}$	The input pin of regulator. Typically a 4.7uF MLCC capacitor is connected from this pin to ground to insure that the input voltage does not sag below the minimum dropout voltage during the load transient response. This pin must always be 1.5V higher than $V_{OUT}$ in order for the device to regulate properly.

❖ **ORDER/MARKING INFORMATION**

Order Information	
<p><b>AX1212A X X</b></p> <pre> graph TD     Root[AX1212A X X] --- LDR[Low Dropout Regulator]     Root --- Package[Package]     Root --- Packing[Packing]                     </pre> <p>E : SOT223-3L    Blank : Tube D : TO252-3L    A : Taping</p>	
Top Marking (SOT223-3L)	Top Marking (TO252-3L)
<p>Logo ← <b>AX</b> 1 2 1 2 → Part number                      A → Functional code                      Y W W X → ID code: internal                      WW: 01~52                      Year: 8=2018                      9=2019                      B=2020                      C=2021                      D=2022                      :                      Z=2044</p>	<p>Logo ← <b>AX</b> 1 2 1 2 → Part number                      A → Functional code                      Y Y W W X → ID code: internal                      WW: 01~52                      Year: 18=2018                      19=2019                      20=2020                      21=2021                      22=2022                      :                      45=2045</p>

**❖ ABSOLUTE MAXIMUM RATINGS** ( $T_A = 25^\circ\text{C}$ )

Characteristics		Symbol	Rating	Unit
DC Supply Voltage		$V_{IN}$	-0.3 to 12	V
Operating Junction Temperature Range		$T_{OP}$	-40 to +125	$^\circ\text{C}$
Maximum junction Temperature		$T_{MJ}$	150	$^\circ\text{C}$
Power Dissipation (multi-layer PCB copper area 10mm*10mm) $T_A=25^\circ\text{C}, T_J=125^\circ\text{C}$	SOT-223	$P_D$	1330	mW
	TO-252		1810	
Storage Temperature		$T_{ST}$	-65 to +150	$^\circ\text{C}$

**❖ ELECTRICAL CHARACTERISTICS**

(Under Operating Conditions)

Characteristics	Conditions	Min	Typ	Max	Units
Operation Input Voltage		2.6	-	12	V
Output Voltage	$I_{OUT}=10\text{mA}, 2.6\text{V} \leq V_{IN} \leq 12\text{V}, T_J = 25^\circ\text{C}$	1.175	1.20	1.225	V
Line Regulation	$I_{OUT}=10\text{mA}, 2.6\text{V} \leq V_{IN} \leq 7\text{V}, T_J=25^\circ\text{C}$ (Note 1,2)	-	1.2	3.6	mV
	$I_{OUT}=10\text{mA}, 2.6\text{V} \leq V_{IN} \leq 12\text{V}, T_J=25^\circ\text{C}$ (Note 1,2)	-	1.8	6	mV
Load Regulation	$V_{IN}=2.7\text{V}, 10\text{mA} < I_{OUT} < 1\text{A}, T_J=25^\circ\text{C}$ (Note 1,2)	-	-	12	mV
Dropout Voltage ( $V_{IN}-V_{OUT}$ )	$I_{OUT}=1\text{A}, \Delta V_{OUT}=1\%V_{OUT}$	-	1.3	1.5	V
Current Limit	$(V_{IN}-V_{OUT}) = 3\text{V}$	1.1	-	-	A
Minimum Load Current	$0^\circ\text{C} \leq T_J \leq 125^\circ\text{C}$	-	5	10	mA
Ripple Rejection	$F=120\text{Hz}, C_{OUT}=4.7\mu\text{F}, I_{OUT}=1\text{A}, V_{IN}=5\text{V}$	-	60	70	dB
Temperature Stability	$I_{OUT} = 10\text{mA}$	-	0.5	-	%
$\theta_{JA}$ Thermal Resistance Junction-to-Ambient (Note 4)	SOT-223 TO-252	-	75 55	-	$^\circ\text{C}/\text{W}$
$\theta_{JC}$ Thermal Resistance Junction-to-Case	SOT-223 TO-252	-	15 10	-	$^\circ\text{C}/\text{W}$

Note1: See thermal regulation specifications for changes in output voltage due to heating effects. Line and load regulation are measured at a constant junction temperature by low duty cycle pulse testing. Load regulation is measured at the output lead = 1/18" from the package.

Note2: Line and load regulation are guaranteed up to the maximum power dissipation of 15W. Power dissipation is determined by the difference between input and output differential and the output current. Guaranteed maximum power dissipation will not be available over the full input/output range.

Note3: Quiescent current is defined as the minimum output current required in maintaining regulation. At 12V input/output differential the device is guaranteed to regulate if the output current is greater than 10mA.

Note4: Tap is connected to the multi-layer PCB copper area 10mm\*10mm.

❖ APPLICATION CIRCUIT

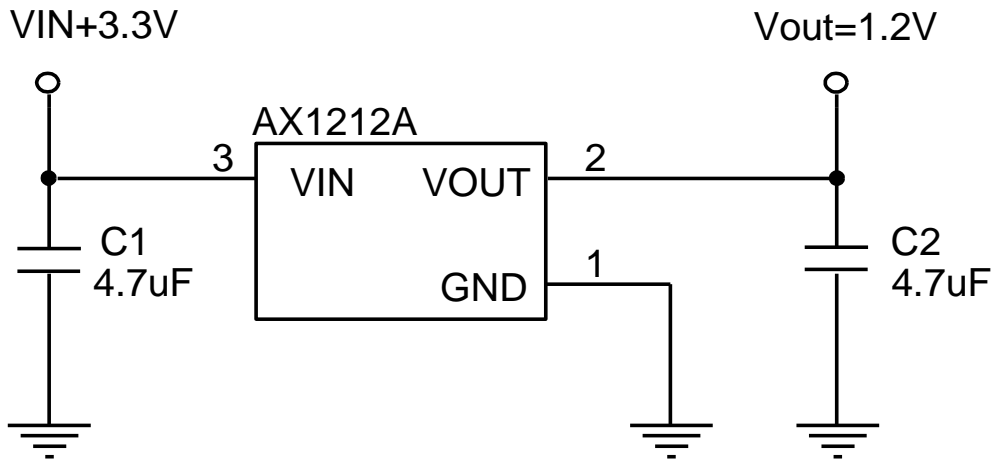

❖ TYPICAL CHARACTERISTICS

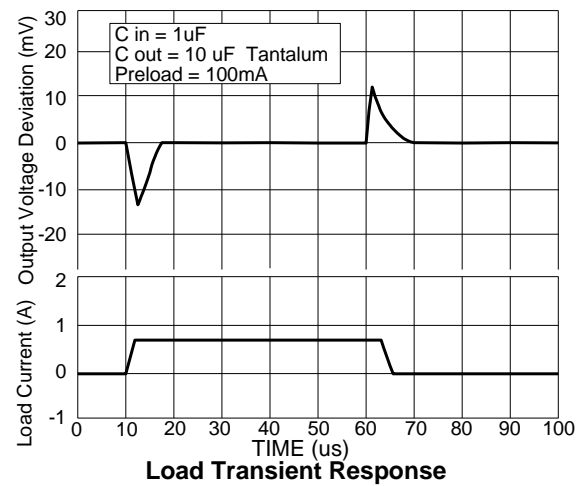
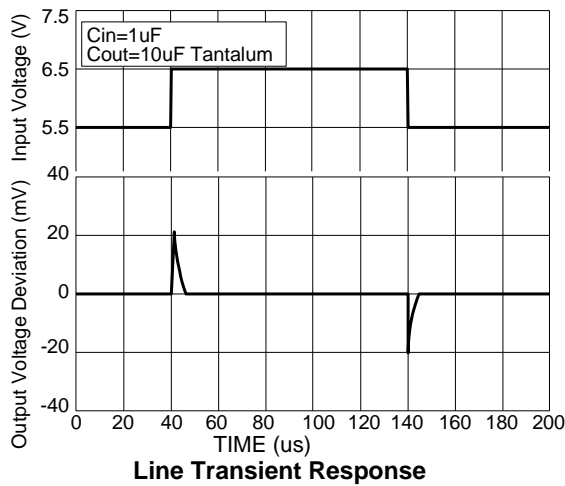
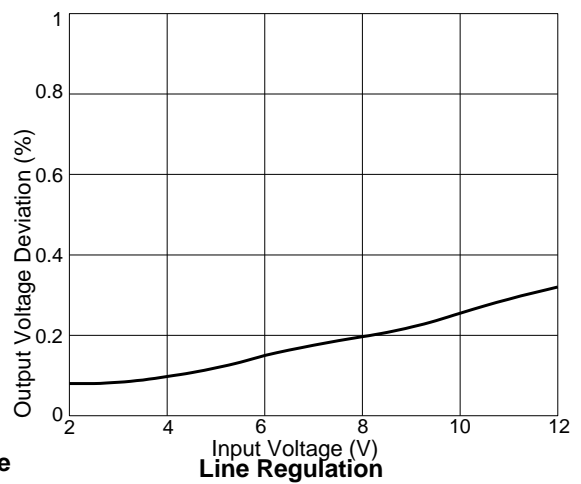
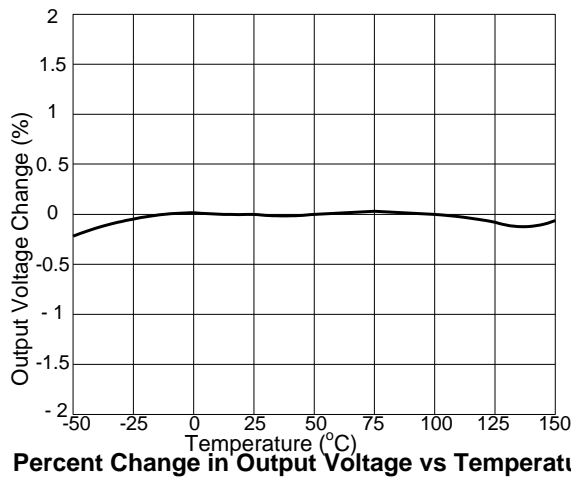
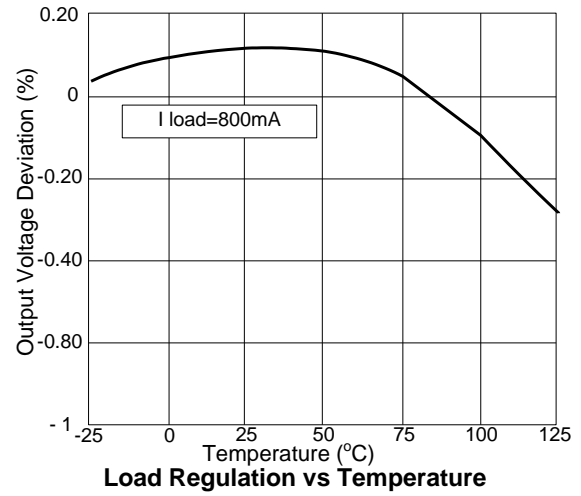
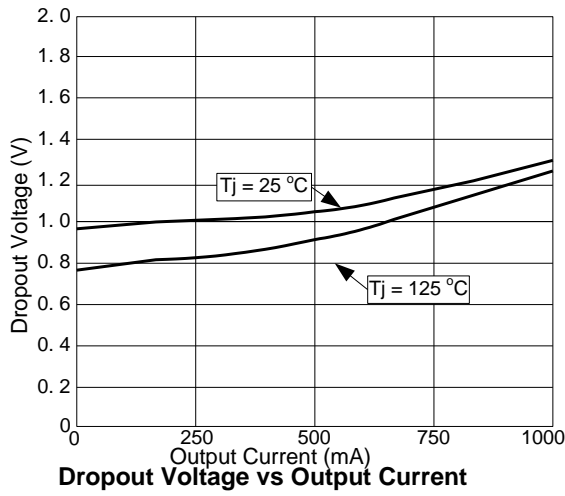

❖ PACKAGE OUTLINES

(1) SOT223-3L

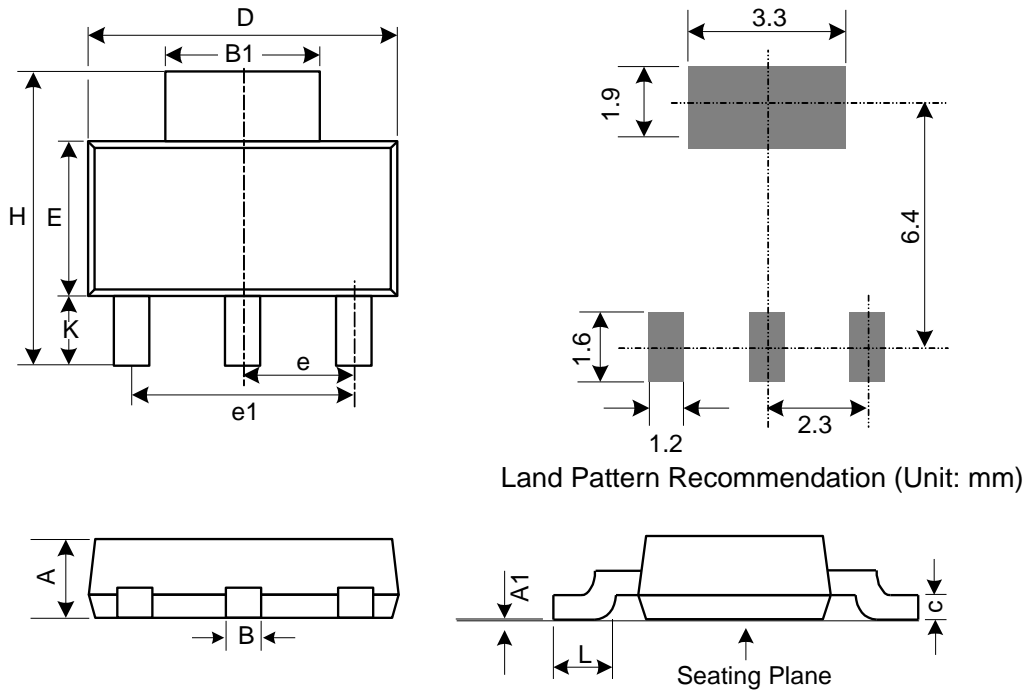

Symbol	Dimensions in Millimeters			Dimensions in Inches		
	Min.	Nom.	Max.	Min.	Nom.	Max.
A	1.4	1.60	1.80	0.055	0.063	0.071
A1	0.02	0.06	0.10	0.001	0.002	0.004
B	0.60	0.72	0.84	0.024	0.028	0.033
B1	2.90	-	3.15	0.114	-	0.124
C	0.28	0.315	0.35	0.011	0.012	0.014
D	6.30	6.50	6.70	0.248	0.256	0.264
E	3.30	3.50	3.70	0.130	0.138	0.146
H	6.70	7.00	7.30	0.264	0.276	0.287
L	0.90	1.00	1.10	0.035	0.039	0.043
K	1.50	1.75	2.00	0.059	0.069	0.079
e	2.3 Basic			0.091 Basic		
e1	4.6 Basic			0.181 Basic		

(2) T0252-3L

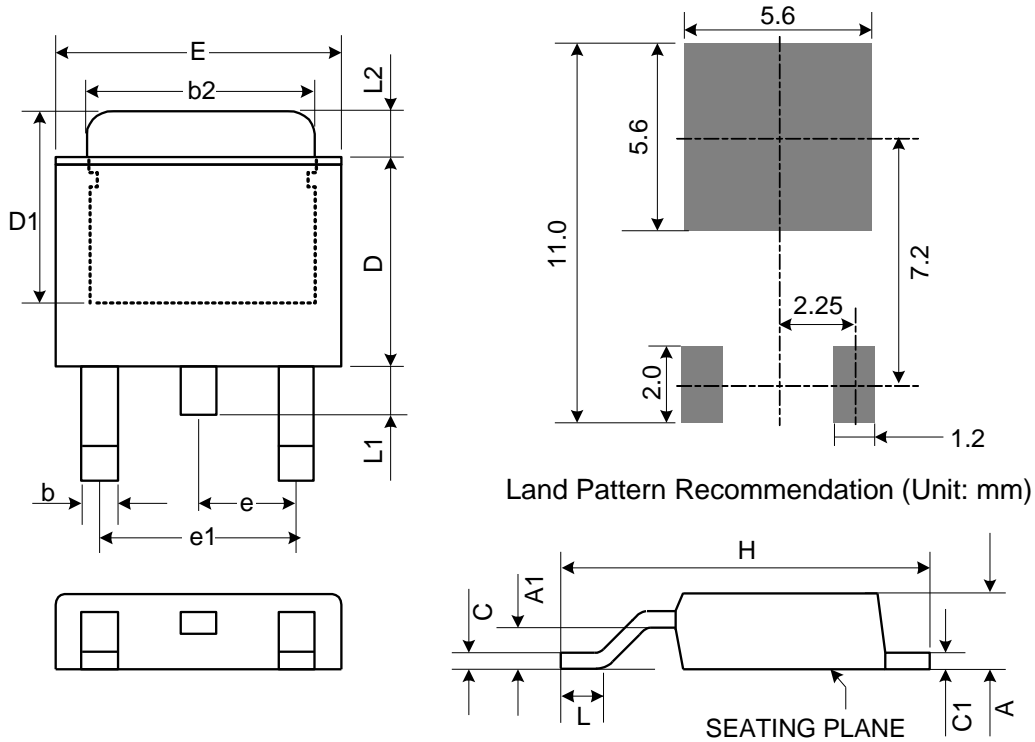

Symbol	Dimensions in Millimeters			Dimensions in Inches		
	Min.	Nom.	Max.	Min.	Nom.	Max.
A	2.18	2.29	2.40	0.086	0.090	0.094
A1	0.89	-	1.14	0.035	-	0.045
b	0.61 TYP.			0.024 TYP.		
b2	5.20	5.35	5.50	0.205	0.211	0.217
C	0.45	0.52	0.58	0.018	0.020	0.023
C1	0.45	0.52	0.58	0.018	0.020	0.023
D	5.40	5.57	6.20	0.213	0.219	0.244
D1	4.57	4.77	4.97	0.180	0.188	0.196
E	6.35	6.58	6.80	0.250	0.259	0.268
e	2.28 BSC.			0.090 BSC.		
e1	4.57 BSC.			0.180 BSC.		
H	9.00	9.70	10.40	0.354	0.382	0.409
L	0.51	-	-	0.020	-	-
L1	0.64	0.83	1.02	0.025	0.033	0.040
L2	0.88	-	1.27	0.035	-	0.050

❖ Carrier tape dimension

SOT223-3L

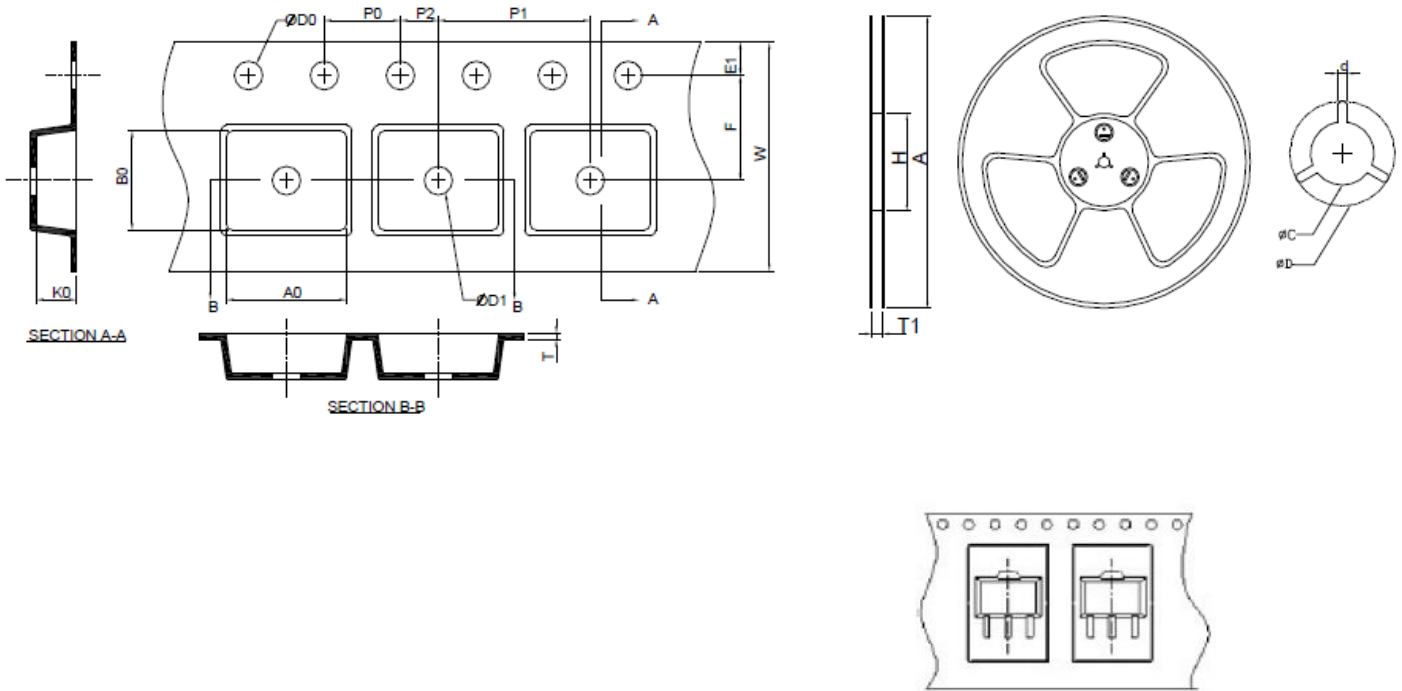

Application	A	H	T1	C	d	D	W	E1	F
SOT-223	320.0±2.00	50 MIN.	12.4+2.00 -0.00	13.0+0.50 -0.20	1.5 MIN.	20.2 MIN.	12.00±0.30	1.75±0.10	5.50±0.05
	P0	P1	P2	D0	D1	T	A0	B0	K0
	4.00±0.10	8.00±0.10	2.00±0.50	1.5+0.10 -0.00	1.5 MIN.	0.6+0.00 -0.40	6.90±0.20	7.50±0.20	2.10±0.20



TO-252-3L

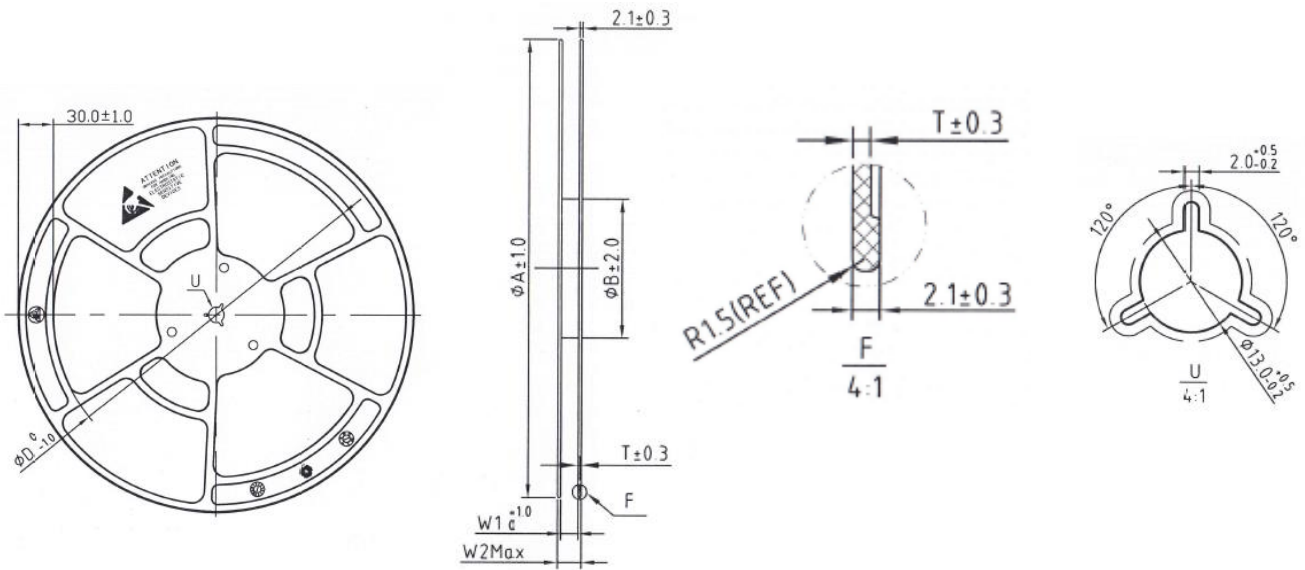

型號規格	適合載帶寬度	圓盤基本尺寸					
		A	B(內徑)	W1	W2Max	T	D
13" - 12X100	12 / 12.2	330	100	12.4	18.4	1.5	270
13" - 16X100	16			16.4	22.4		
13" - 24X100	24			24.4	30.4		

(mm)

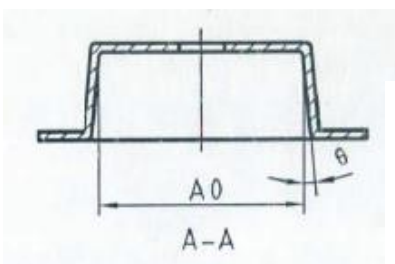
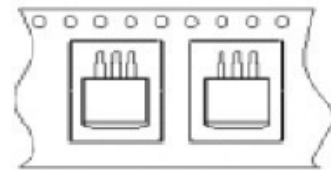
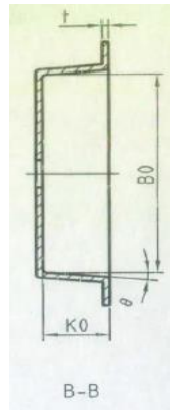
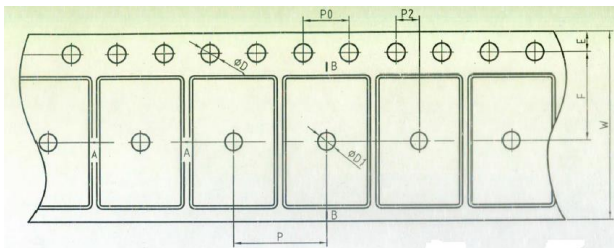

E	F	P <sub>2</sub>	D	D <sub>1</sub>	P <sub>0</sub>	10P <sub>0</sub>
1.75±0.10	7.50±0.10	2.00±0.10	1.50 <sup>-0.1</sup> <sub>0</sub>	1.50 <sup>+0.25</sup> <sub>0</sub>	4.00±0.10	40.0±0.20
W	P	A <sub>0</sub>	B <sub>0</sub>	K <sub>0</sub>	t	θ
16.00±0.10	8.00±0.10	6.90±0.10	10.50±0.10	2.65±0.10	0.30±0.02	5°TYP

(mm)