

Dual High-Efficiency PWM Step-Down **DC-DC Converter**

❖ GENERAL DESCRIPTION

The AX3515A is a dual high-efficiency Pulse-Width-Modulated (PWM) step-down DC-DC converter. It is capable of delivering 1A output current over a wide input voltage range from 2.5V to 5.5V, the AX3515A is ideally suited for portable electronic devices that are powered from 1-cell Li-ion battery or from other power sources within the range such as cellular phones, PDAs and other handheld devices.

Two operational modes are available: PWM/Low-Dropout auto-switch and shutdown modes. Internal synchronous rectifier with low RDS(ON) dramatically reduces conduction loss at PWM mode. No external Schottky diode is required in practical application.

The AX3515A enters Low-Dropout mode when normal PWM cannot provide regulated output voltage by continuously turning on the upper PMOS. The AX3515A enter shutdown mode and consumes less than 0.1 μ A when EN pin is pulled low.

The switching ripple is easily smoothed-out by small package filtering elements due to a fixed operation frequency of 1.4MHz. This along with small TDFN-10L (3x3) package provides small PCB area application. Other features include soft start, lower internal reference voltage with 2% accuracy, over temperature protection, and over current protection.

❖ FEATURES

- 2.5V to 5.5V Input Voltage Range
- Adjustable Output Voltage from 0.6V to V_{IN}
- 1A Output Current/per channel
- High Efficiency : up to 95%
- No Schottky Diode Required
- 1.4MHz Fixed-Frequency PWM Operation
- Small 10-Lead TDFN Package
- RoHS and Halogen free compliance.

❖ BLOCK DIAGRAM

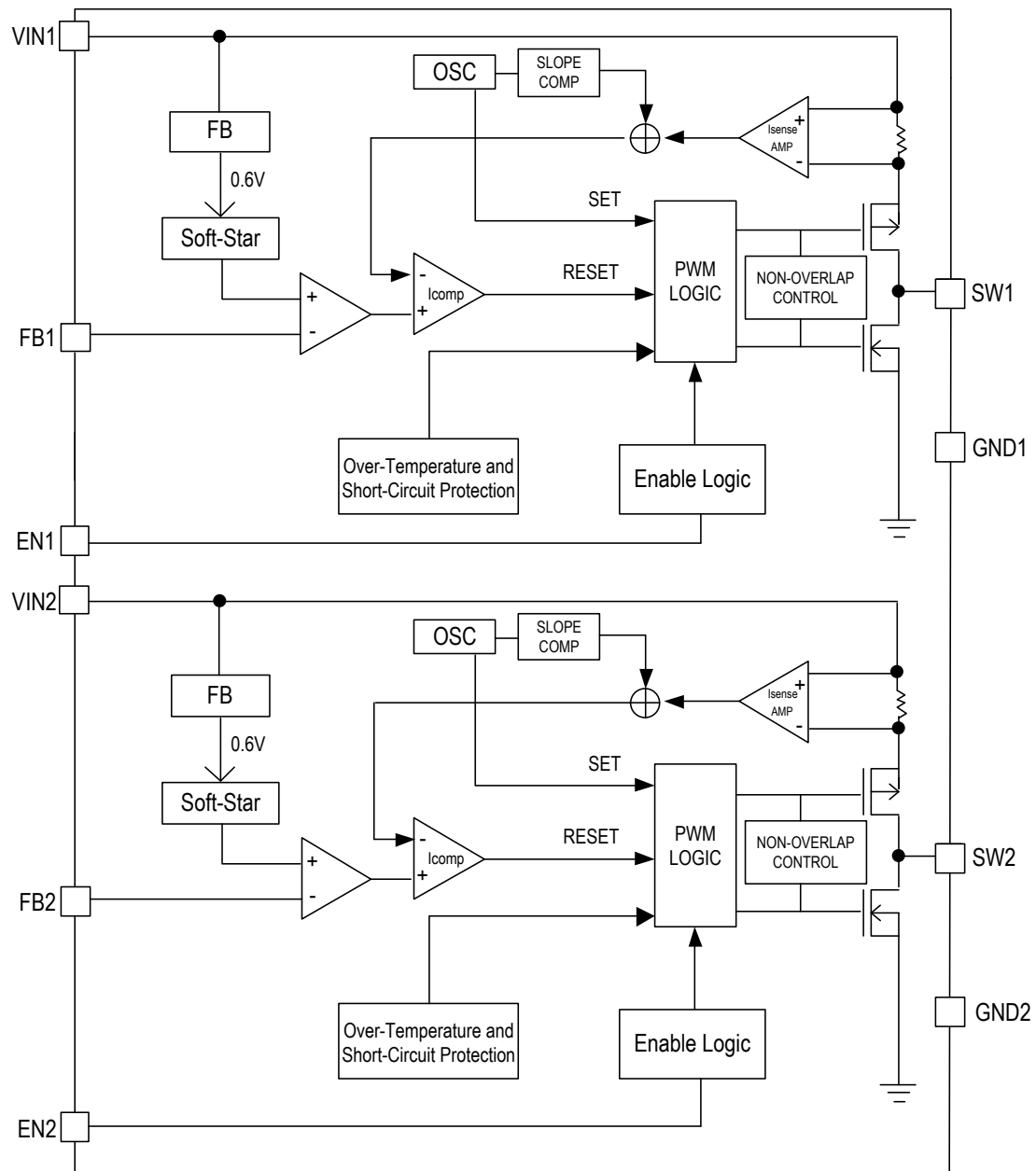

❖ **PIN ASSIGNMENT**

The package of AX3515A is TDFN-10L; the pin assignment is given by:

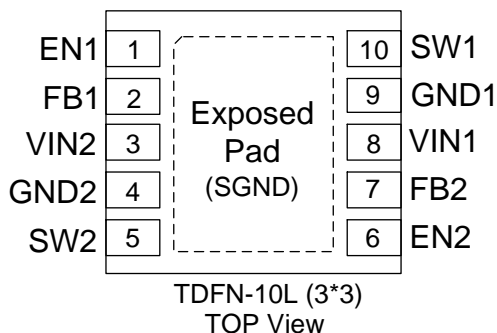

Name	Description
EN1	Chip Enable of Channel 1 (Active High). VEN1 ≤ VIN1.
FB1	Feedback of Channel 1.
VIN2	Power Input of Channel 2.
GND2,1	Ground. The exposed pad must be soldered to a large PCB and connected to GND for maximum power dissipation.
SW2	Pin for Switching of Channel 2.
EN2	Chip Enable of Channel 2 (Active High). VEN2 ≤ VIN2.
FB2	Feedback of Channel 2.
VIN1	Power Input of Channel 1.
SW1	Pin for Switching of Channel 1.

❖ **ORDER/MARKING INFORMATION**

Order Information	Top Marking
<p>AX3515A xxx x</p>	<p>3 5 1 5 A → Part number Y Y W W X → ID code: internal</p> <p> └─┬──┘ WW: 01~52 Year: 18=2018 19=2019 20=2020 21=2021 22=2022 45=2045</p>

❖ **ABSOLUTE MAXIMUM RATINGS** (at TA=25°C)

Characteristics	Symbol	Rating	Unit
Supply Input Voltage	VIN1/ VIN2	-0.3 to 6.5	V
EN1, FB1, LX1, EN2, FB2 and LX2 Pin Voltage		-0.3 to VIN + 0.3	V
Power Dissipation, PD @ TA = 25°C	PD	2.2	W
Lead Temperature (Soldering, 10 sec.)		260	°C
Storage Temperature Range	TST	-65 to 150	°C
Junction Temperature	TJ	150	°C
Thermal Resistance from Junction to case	θJC	15	°C/W
Thermal Resistance from Junction to ambient	θJA	45	°C/W

Note: θJA is measured with the PCB copper area of approximately 1 in²(Multi-layer). That need connect to exposed pad.

❖ RECOMMENDED OPERATING CONDITIONS

Characteristics	Symbol	Rating	Unit
Supply Input Voltage	V_{IN}	2.5 to 5.5	V
Junction Temperature Range	T_J	-40 to 125	°C
Ambient Temperature Range	T_A	-40 to 85	°C

Note: The device is not guaranteed to function outside its operating conditions.

❖ ELECTRICAL CHARACTERISTICS

($V_{IN}=3.6V$, $V_{OUT}=2.5V$, $L=2.2\mu H$, $C_{IN}=4.7\mu F$, $C_{OUT}=10\mu F$, $T_A=25^\circ C$, $I_{MAX}=1A$ unless otherwise specified)

Characteristics	Symbol	Conditions	Min	Typ	Max	Units
Channel 1 and Channel 2						
Input Voltage Range	V_{IN}		2.5	-	5.5	V
Under Voltage Lock Out threshold	UVLO		-	1.8	-	V
Hysteresis			-	0.1	-	V
Quiescent Current (per channel)	I_Q	$I_{OUT}=0mA$, $V_{FB}=1V$	-	250	350	μA
Shutdown Current	I_{SD}	$V_{EN1}=V_{EN2}=0V$	-	0.1	1	μA
Feedback Voltage	V_{FB}	For Adjustable Output Voltage	0.588	0.6	0.612	V
Output Voltage Accuracy	ΔV_{OUT}	$V_{IN}=2.5V$ to $5.5V$, $0A < I_{OUT} < 1A$	-3	-	+3	%
FB Input Current	I_{FB}	$V_{FB} = V_{IN}$	-50	-	50	nA
RDS(ON) of P-MOSFET	$R_{DS(ON)_P}$	$V_{FB}=0V$, $I_{OUT}= 500mA$	-	0.35	-	Ω
RDS(ON) of N-MOSFET	$R_{DS(ON)_N}$	$I_{OUT}= 500mA$ (Note 1)	-	0.3	-	Ω
P-Channel Current Limit	I_{LIM_P}		1.2	1.4	-	A
EN High-Level Input Voltage	V_{EN_H}		1.5	-	-	V
EN Low-Level Input Voltage	V_{EN_L}		-	-	0.4	V
Oscillator Frequency	f_{OSC}	SW Pin	1.1	1.4	1.7	MHz
Maximum Duty Cycle		$V_{FB}=0.5V$	100	-	-	%
SW Leakage Current	I_{SW}	$V_{IN}=3.6V$, $V_{SW}=0V$ or $V_{SW}=3.6V$	-1	-	1	μA
Thermal Shutdown Temperature	T_{SD}		-	140	-	°C
Thermal Shutdown Hysteresis	T_{SH}		-	30	-	°C

Note1: Guarantee by design.

❖ APPLICATION CIRCUIT

Adjustable Voltage Regulator

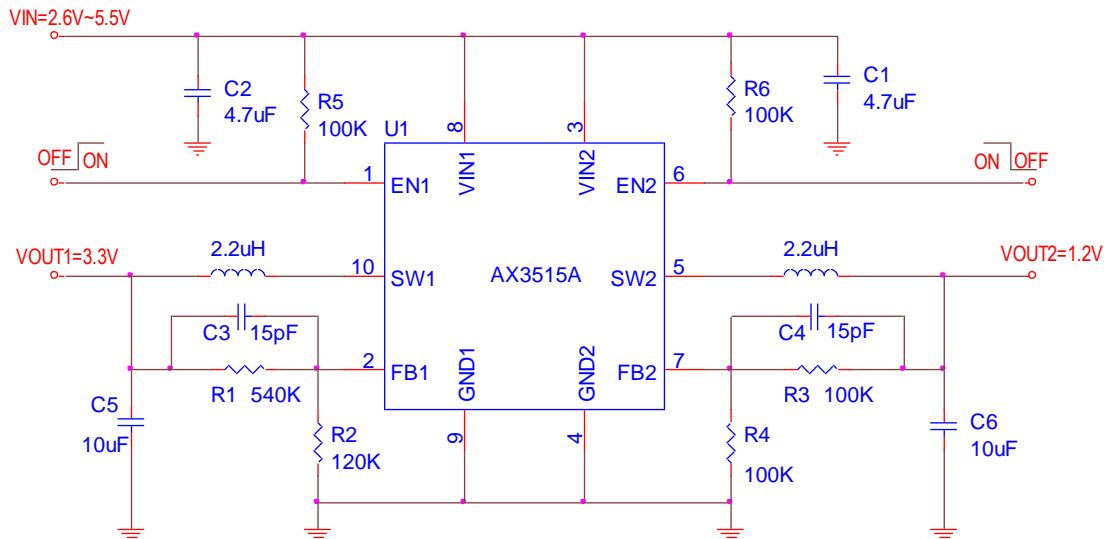

$$V_{OUT1} = V_{FB1} \times \left(1 + \frac{R1}{R2}\right), V_{OUT2} = V_{FB2} \times \left(1 + \frac{R3}{R4}\right)$$

$R2, R4 : \text{Rang} = 50k \sim 330k$

❖ FUNCTION DESCRIPTIONS

Operation

AX3515A is a dual channel, monolithic switching mode Step-Down DC-DC converter. It utilizes internal MOSFETs to achieve high efficiency and can generate very low output voltage by using internal reference at 0.6V. It operates at a fixed switching frequency, and uses the slope compensated current mode architecture. This Step-Down DC-DC Converter supplies 1A output current by each channel with input voltage range from 2.5V to 5.5V.

Current Mode PWM Control

Slope compensated current mode PWM control provides stable switching and cycle-by-cycle current limit for excellent load and line responses and protection of the internal main switch (P-CH MOSFET) and synchronous rectifier (N-CH MOSFET). During normal operation, the internal P-CH MOSFET is turned on for a certain time to ramp the inductor current at each rising edge of the internal oscillator, and switched off when the peak inductor current is above the error voltage. The current comparator, I_{COMP} , limits the peak inductor current. When the main switch is off, the synchronous rectifier will be turned on immediately and stay on until either the inductor current starts to reverse, beginning of the next clock cycle.

❖ **APPLICATION INFORMATION**

Setting the Output Voltage

Application circuit item shows the basic application circuit with AX3515A adjustable output version. The external resistor sets the output voltage according to the following equation:

$$V_{OUT1} = 0.6V \times \left(1 + \frac{R1}{R2}\right), V_{OUT2} = 0.6V \times \left(1 + \frac{R3}{R4}\right)$$

Table 1 Resistor select for output voltage setting

V _{OUT}	R2/R4	R1/R3
1.2V	300K	300K
1.5V	300K	450K
1.8V	300K	600K
2.5V	150K	470K
3.3V	120K	540K

Inductor Selection

For most designs, the AX3515A operates with inductors of 2.2μH to 3.3μH. Low inductance values are physically smaller but require faster switching, which results in some efficiency loss. The inductor value can be derived from the following equation:

$$L = \frac{V_{OUT} \times (V_{IN} - V_{OUT})}{V_{IN} \times \Delta I_L \times f_{OSC}}$$

Where is inductor Ripple Current. Large value inductors lower ripple current and small value inductors result in high ripple currents. Choose inductor ripple current approximately 20% of the maximum load current 1000mA, ΔI_L=200mA.

Table 2 Inductor select for output voltage setting (V_{IN} =3.6V)

V _{OUT}	1.2V	1.5V	1.8V	2.5V
Inductor	2.2uH	2.2uH	2.2uH	2.2uH
Part Number WE-TPC	7440430022	7440430022	7440430022	7440430022

Note: Part type MH or M (www.we-online.com)

For optimum voltage-positioning load transients, choose an inductor with DC series resistance in the 50mΩ to 150mΩ range. For higher efficiency at heavy loads (above 200mA), or minimal load regulation (but some transient overshoot), the resistance should be kept below 100mΩ. The DC current rating of the inductor should be at least equal to the maximum load current plus half the ripple current to prevent core saturation (1000mA+100mA).

Input Capacitor Selection

The input capacitor reduces the surge current drawn from the input and switching noise from the device. The input capacitor impedance at the switching frequency shall be less than input source impedance to prevent high frequency switching current passing to the input. A low ESR input capacitor sized for maximum RMS current must be used. Ceramic capacitors with X5R or X7R dielectrics are highly recommended because of their low ESR and small temperature coefficients. A 4.7μF ceramic capacitor for most applications is sufficient.

Output Capacitor Selection

The output capacitor is required to be 10uF to keep the output voltage ripple small and to ensure regulation loop stability. The output capacitor must have low impedance at the switching frequency. Ceramic capacitors with X5R or X7R dielectrics are recommended due to their low ESR and high ripple current.

Compensation Capacitor Selection

The compensation capacitors for increasing phase margin provide additional stability. It is required 15pF, Please refer to Demo Board Schematic to design.

Output Voltage Programming

The resistive divider allows the FB pin to sense a fraction of the output voltage as shown in setting the Output Voltage.

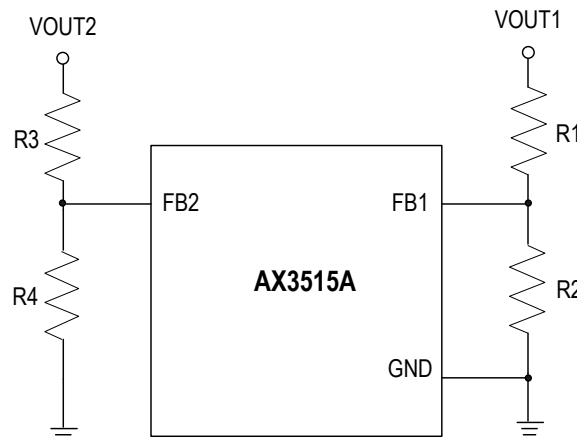

Setting the Output Voltage

For adjustable voltage mode, the output voltage is set by an external resistive divider according to the following equation:

$$V_{OUT1} = V_{FB1} \times (1 + R1/R2), \quad V_{OUT2} = V_{FB2} \times (1 + R3/R4)$$

Where V_{FB} is the Feedback voltage (0.6V typical)

Thermal Considerations

The maximum power dissipation depends on the thermal resistance of IC package, PCB layout, the rate of surroundings airflow and temperature difference between junctions to ambient. The maximum power dissipation can be calculated by following formula:

$$P_{D(MAX)} = (T_{J(MAX)} - T_A) / \theta_{JA}$$

Where $T_{J(MAX)}$ is the maximum junction temperature, T_A is the ambient temperature and the θ_{JA} is the junction to ambient thermal resistance. For recommended operating conditions specification of AX3515A DC/DC converter, where $T_{J(MAX)}$ is the maximum junction temperature of the die and T_A is the ambient temperature. The junction to ambient thermal resistance θ_{JA} is layout dependent. For TDFN-10L (3x3) packages, the thermal resistance θ_{JA} is 45°C/W on the 1 in² Multi-layer PCB copper area (The IC exposed pad must be connected to the PCB Copper area) two-layers thermal test board. The maximum power dissipation at $T_A = 25^\circ\text{C}$ can be calculated by following formula:

$$P_{D(MAX)} = (125^\circ\text{C} - 25^\circ\text{C}) / (45^\circ\text{C/W}) = 2.22\text{W for TDFN-10L (3x3) package}$$

The maximum power dissipation depends on operating ambient temperature for fixed $T_{J(MAX)}$ and thermal resistance θ_{JA} .

Layout Guide

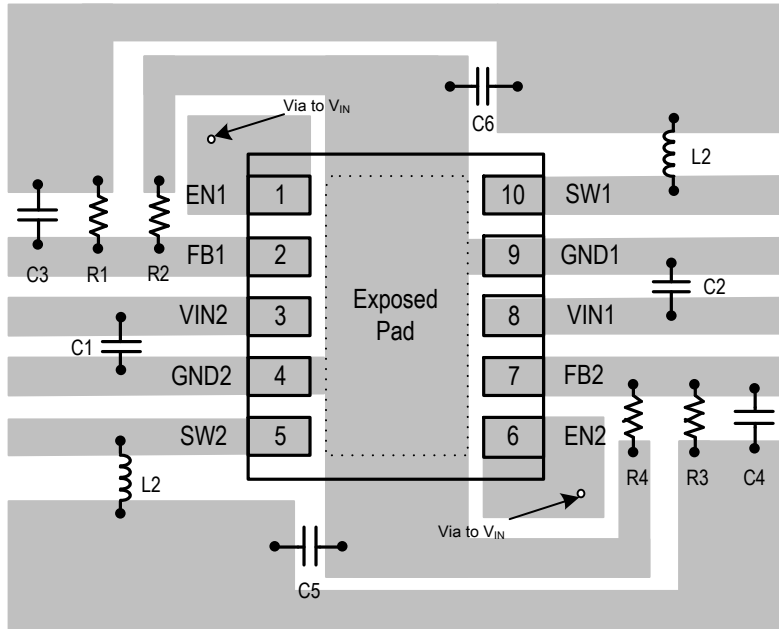

❖ TYPICAL CHARACTERISTICS

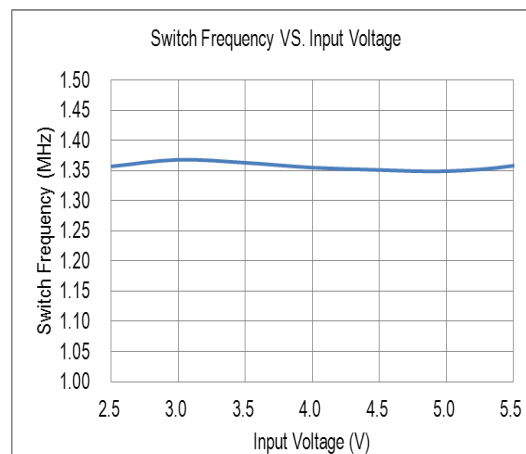
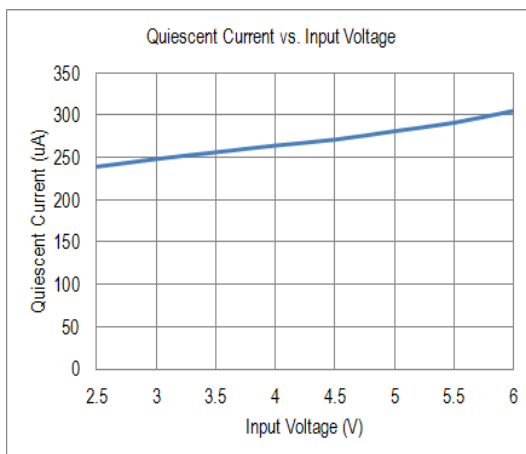
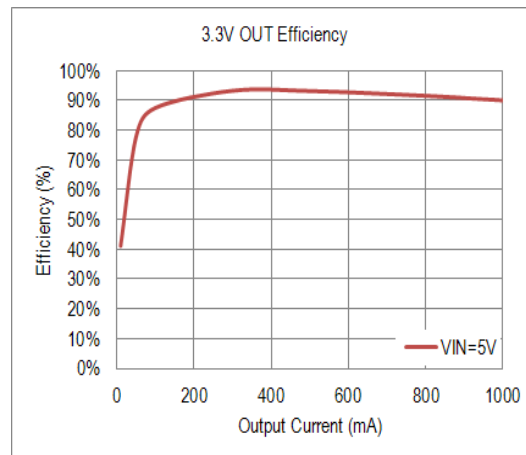
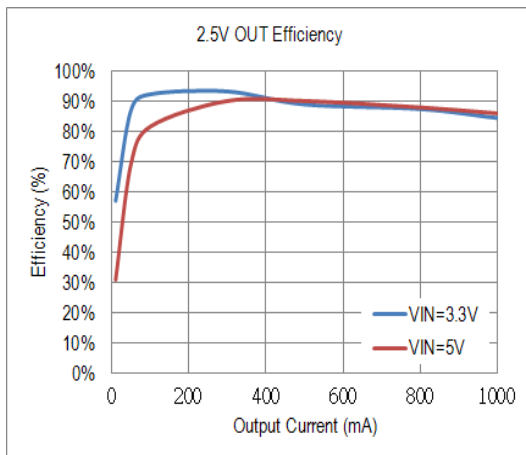
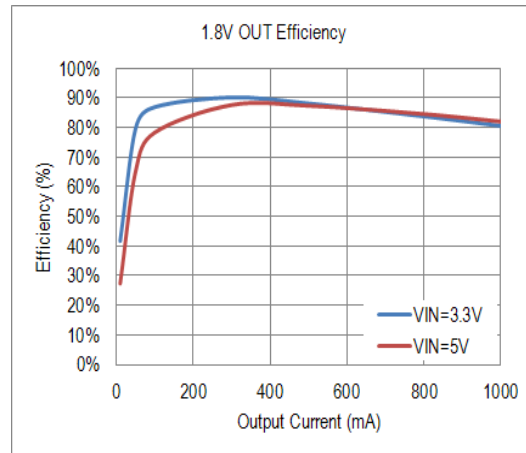
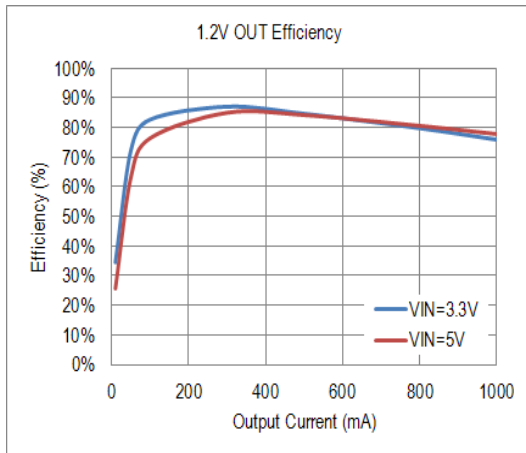

❖ TYPICAL CHARACTERISTICS (COUNTINOUS)

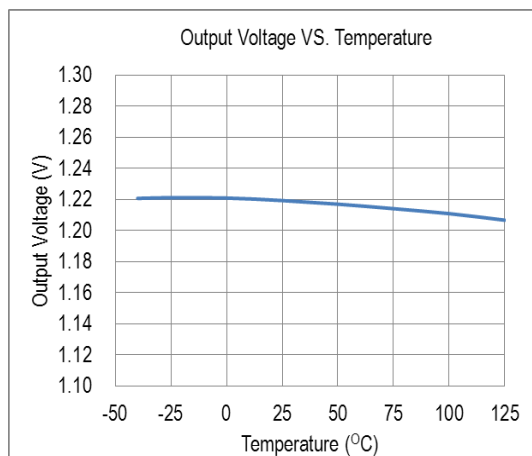
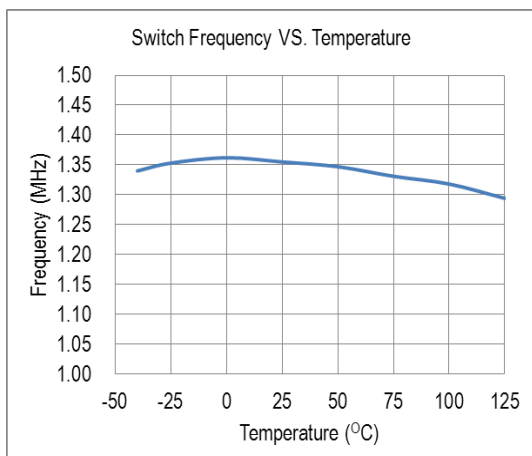
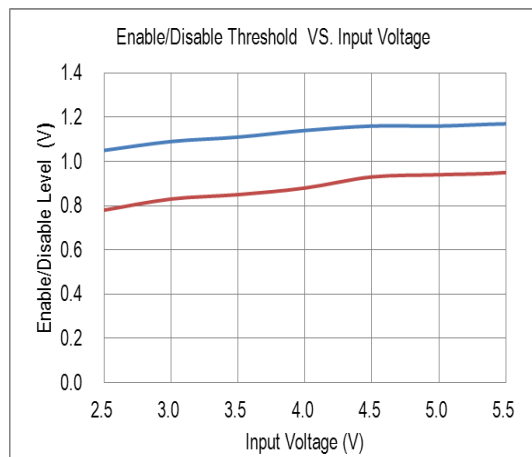
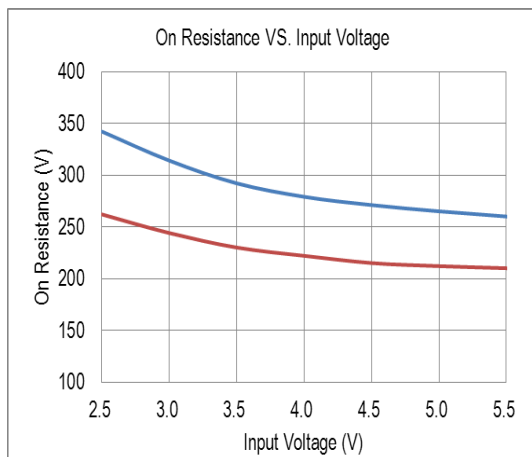
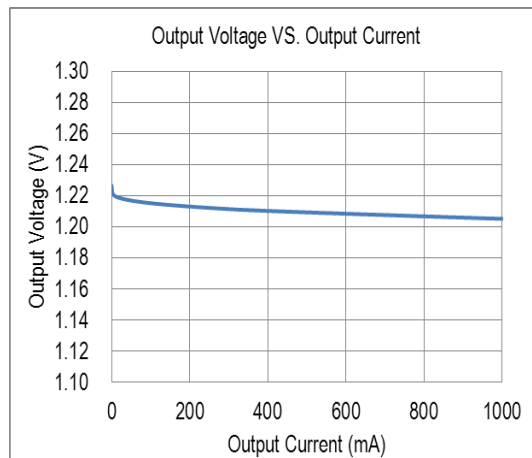
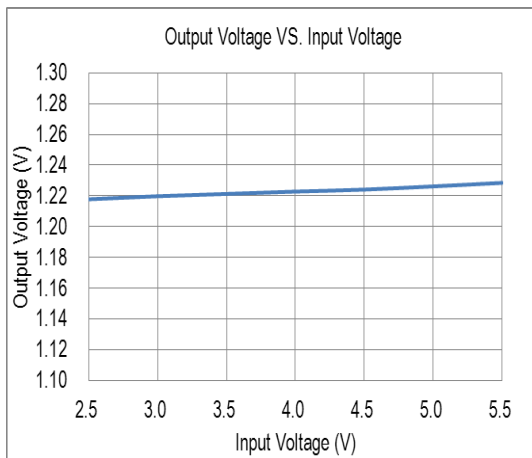

❖ TYPICAL CHARACTERISTICS (COUNTINOUS)

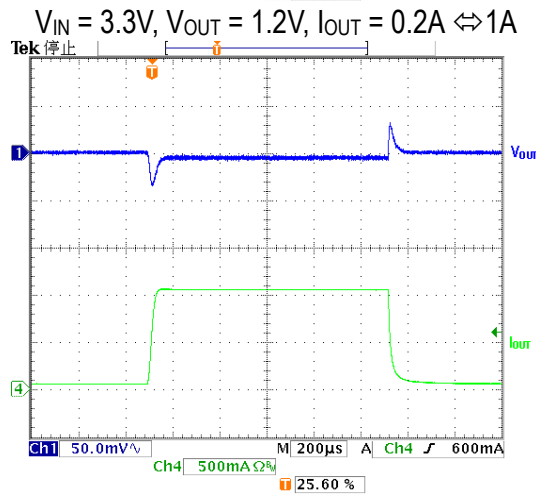
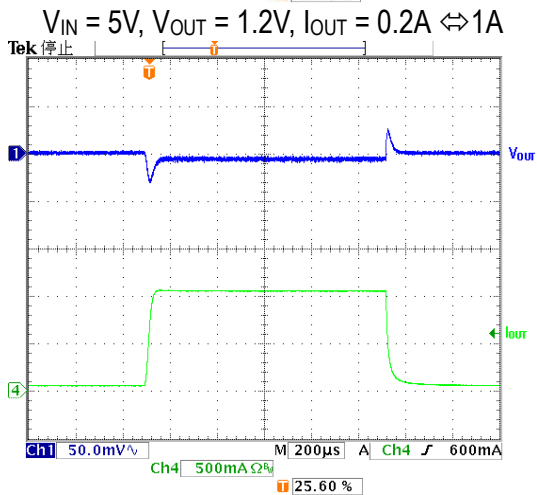
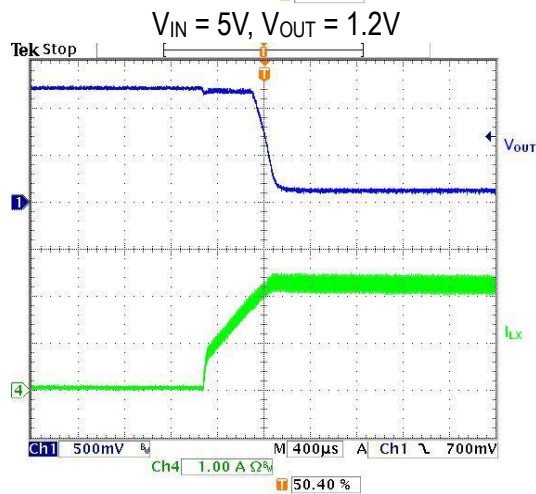
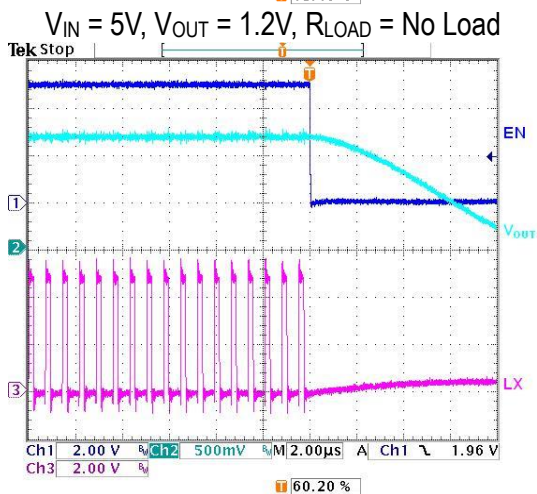
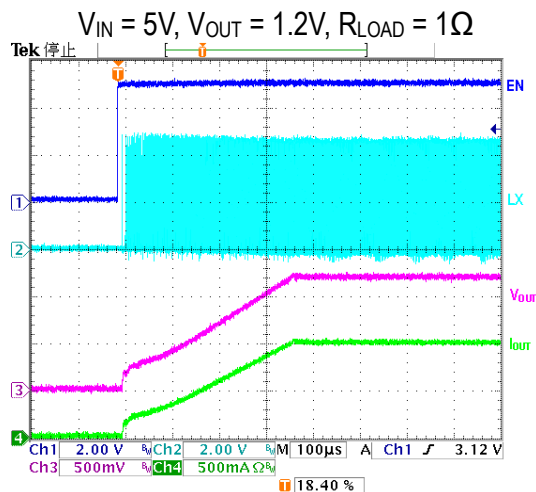
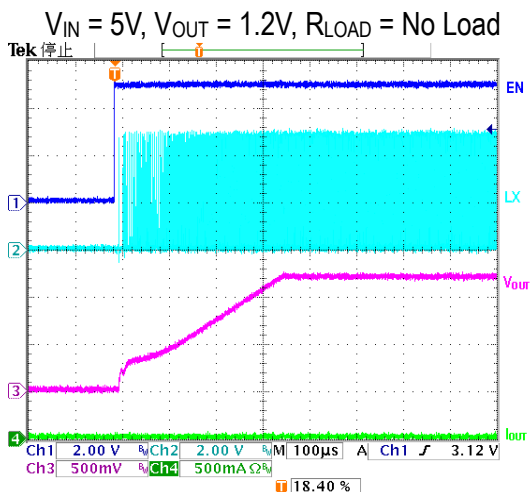

❖ PACKAGE OUTLINES

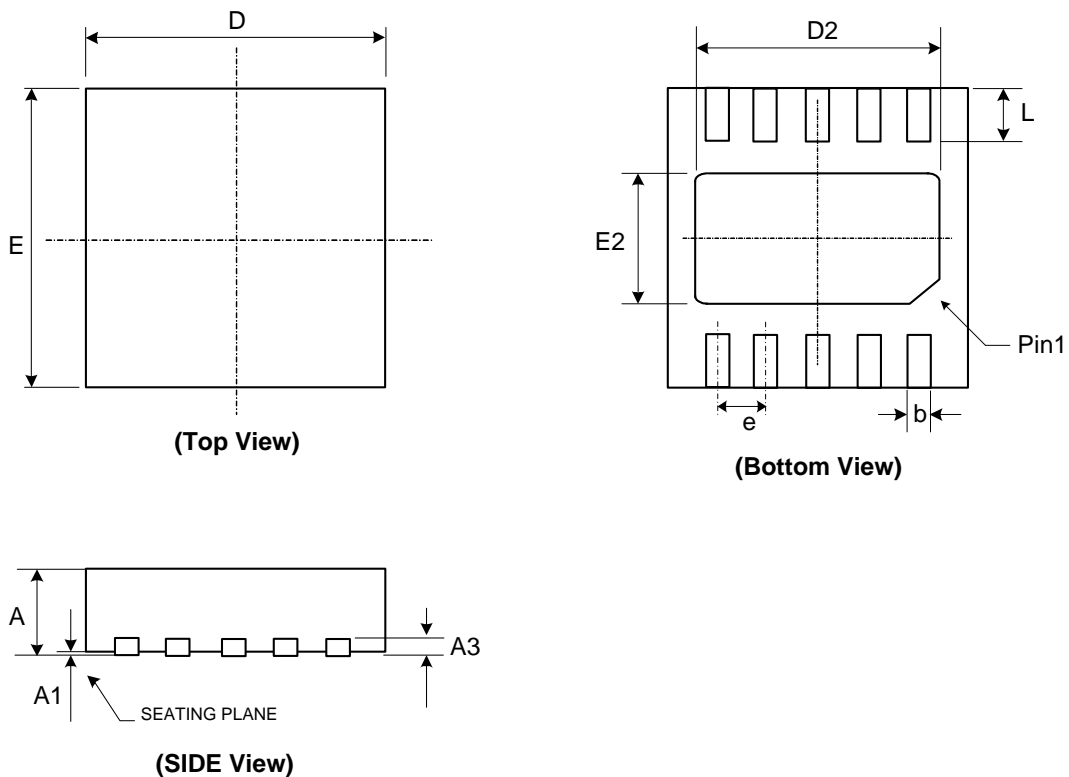

Symbol	Dimensions in Millimeters			Dimensions in Inches		
	Min.	Nom.	Max.	Min.	Nom.	Max.
A	0.70	0.75	0.80	0.028	0.030	0.031
A1	0.00	0.02	0.05	0.000	0.001	0.002
A3	0.20 REF.			0.008 REF.		
b	0.18	0.25	0.30	0.007	0.010	0.012
D	2.90	3.00	3.10	0.114	0.118	0.122
D2	2.20	2.40	2.50	0.087	0.094	0.098
E	2.90	3.00	3.10	0.114	0.118	0.122
E2	1.50	1.60	1.70	0.059	0.063	0.070
e	0.50 BSC.			0.020 BSC.		
L	0.30	0.40	0.50	0.012	0.016	0.020

❖ Carrier tape dimension

TDFN-10L(3x3)

