

## **2.8A, Wide-Input Sensorless CC/CV Step-Down** **DC/DC Converter**

### ❖ GENERAL DESCRIPTION

AX3051/A is a wide input voltage, high efficiency Active CC step-down DC/DC converter that operates in either CV (Constant Output Voltage) mode or CC (Constant Output Current) mode.

AX3051/A consists of step-down switching regulator with PWM control. The device includes a reference voltage source, oscillation circuit, error amplifier and etc.

AX3051/A provides low-ripple power, high efficiency, and excellent transient characteristics. The PWM control circuit is able to the duty ratio linearly forms 0 up to 90%. An over current protection function is built outside that it can set by a resistance. An external compensation is easily to system stable; the low ESR output capacitor can be used.

With the addition of an internal N-channel Power MOS, a coil, capacitors, and a diode connected externally, these ICs can function as step-down switching regulators. They serve as ideal power supply units for portable devices when coupled with the SOP-8L-EP packages, providing such outstanding features as low current consumption. Since this converter can accommodate an input voltage up to 34V.

❖ **FEATURES**

- Input Voltage : 8V to 34V
- Vout Accuracy ( $V_{FB}=1V$ )  $\pm 1\%$  /  $\pm 2\%$
- CC/CV mode(Constant Current and Constant Voltage)
- Up to 2.8A output current
- $\pm 5\%$ / $\pm 15\%$  Current limit Accuracy
- Duty ratio : 0% to 90% PWM control
- Oscillation frequency :
  - AX3051: 100KHz
  - AX3051A: 250KHz
- Thermal Shutdown function.
- Short Circuit Protect (SCP).
- Built-in internal LX N-channel MOS.
- Current mode non-synchronous PWM converter
- External current limit setting.
- Over Voltage Protection 5.8V.
- Built in adjustable line-compensation.
- SOP-8L-EP Pb-Free packages
- RoHS and Halogen free compliance

❖ **APPLICATIONS**

- Car charger
- Portable charger Device.

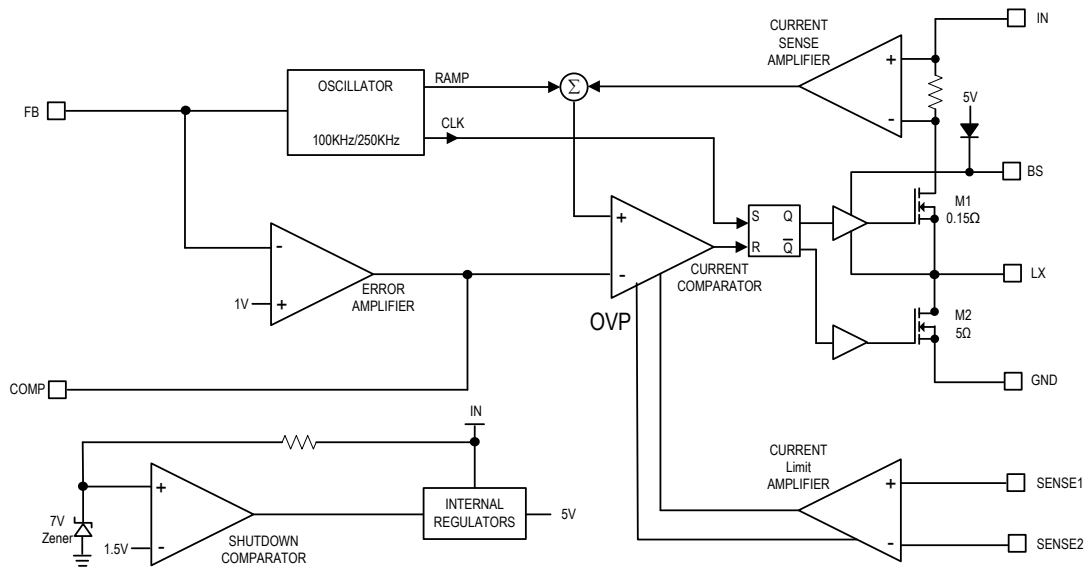
**❖ BLOCK DIAGRAM**

**❖ PIN ASSIGNMENT**

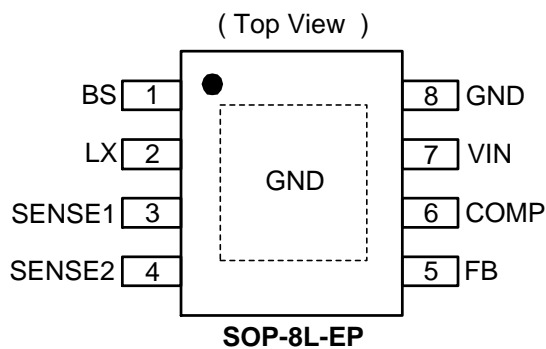
The package of AX3051/A is SOP-8L-EP; the pin assignment is given by:



| Name          | Description   |
|---------------|---|
| <b>BS</b>     | Bootstrap Pin. This provides power to the internal high-side MOSFET gate driver. Connect a 0.1uF capacitor from BS pin to LX pin. |
| <b>LX</b>     | Power Switching Output to External Inductor.  |
| <b>SENSE1</b> | Current Sense input1  |
| <b>SENSE2</b> | Current Sense input2  |
| <b>FB</b>     | Output voltage feedback control   |
| <b>COMP</b>   | Error Amplifier Output. This pin is used to compensate the converter.   |
| <b>VIN</b>    | Power Supply Input. Bypass this pin with a 0.1uF ceramic capacitor to GND, placed as close to the IC as possible.                 |
| <b>GND</b>    | GND pin   |

## ❖ ORDER/MARKING INFORMATION

| Order Information   | Top Marking  |
|---|--|
| <p style="font-size: 24px; font-weight: bold; text-align: center;">AX3051 X XX X</p> <div style="display: flex; justify-content: space-around; text-align: center;"> <div style="width: 30%;"> <p>Blank:100KHz<br/>A:250KHz</p> </div> <div style="width: 30%;"> <p>Package Type<br/>ES: SOP-8L-EP</p> </div> <div style="width: 30%;"> <p>Packing<br/>Blank : Tube<br/>A : Taping</p> </div> </div> <p>Note:<br/>Bin 2: ±5%, Bin 3: ±15% (Sense Voltage)</p> | <p style="font-size: 18px; font-weight: bold;">Logo ← AX 3 0 5 1 → Part number</p> <p style="font-size: 18px; font-weight: bold;">A Y Y W W X → ID code: internal</p> <p style="font-size: 18px; font-weight: bold;">AX3051A</p> <p>WW: 01~52</p> <p>Year: 18=2018<br/>19=2019<br/>20=2020<br/>21=2021<br/>22=2022<br/>⋮<br/>45=2045</p> |

## ❖ ABSOLUTE MAXIMUM RATINGS (at $T_A = 25^\circ\text{C}$ )

| Characteristics                             | Symbol        | Rating                         | Unit |
|---|---------------|--------------------------------|------|
| IN to GND                                   |               | -0.3 to 40                     | V    |
| LX to GND                                   |               | -1 to $V_{IN} + 1$             | V    |
| BS to GND                                   |               | $V_{LX} - 0.3$ to $V_{LX} + 7$ | V    |
| FB, SENSE1, SENSE2, COMP to GND             |               | -0.3 to + 6                    | V    |
| Operating Junction Temperature              |               | -40 to 150                     | °C   |
| Storage Junction Temperature                |               | -65 to 150                     | °C   |
| Lead Temperature (Soldering 10 sec.)        |               | 300                            | °C   |
| Thermal Resistance from Junction to case    | $\theta_{JC}$ | 15                             | °C/W |
| Thermal Resistance from Junction to ambient | $\theta_{JA}$ | 75                             | °C/W |

Note :  $\theta_{JA}$  is measured with the PCB copper are (need connect to Exposed pad) of approximately 1 in<sup>2</sup>(Multi-layer).

**❖ ELECTRICAL CHARACTERISTICS**

 ( $V_{IN}=12V$ ,  $T_A=25^{\circ}C$ , unless otherwise specified)

| Characteristics   | Symbol      | Conditions                          | Min  | Typ | Max  | Units       |
|---|-------------|-------------------------------------|------|-----|------|-------------|
| Input Voltage   |             |                                     | 8    | -   | 34   | V           |
| OVP detect voltage  | $V_{OVP}$   | Internal define                     | -    | 5.8 | -    | V           |
| OVP Hysteresis  |             |                                     | -    | 0.3 | -    | V           |
| Quiescent Current   | $I_{CCQ}$   | $V_{FB} = 1.5V$ , force driver off. | -    | 2   | -    | mA          |
| Standby Supply Current                                      |             | $V_0 = 5V$ , No Load                | -    | 10  | 15   | mA          |
| Line compensation Current                                   | $I_{FB}$    | $V_{SENSE1}-V_{SENSE2}=100mV$       | 3.5  | 5   | 6.5  | uA          |
| Feedback Voltage(Bin2)                                      |             | AX3051ES                            | 0.99 | 1   | 1.01 | V           |
| Feedback Voltage(Bin2)                                      |             | AX3051AES                           | 0.98 | 1   | 1.02 | V           |
| Feedback Voltage(Bin3)                                      |             | AX3051ES/AX3051AES                  | 0.98 | 1   | 1.02 | V           |
| High-Side Switch On Resistance                              | $R_{DSON}$  | $V_{IN}=12V$ , $I_{OUT} = 1A$       | -    | 150 | 200  | mΩ          |
| Low-Side Switch On Resistance                               | $R_{DSON}$  | $V_{IN}=12V$                        | -    | 5   | -    | Ω           |
| Switching Frequency   | $F_{OSC}$   | AX3051; $I_{OUT}=200mA$             | 80   | 100 | 120  | KHz         |
|   |             | AX3051A; $I_{OUT}=200mA$            | 200  | 250 | 300  | KHz         |
| Maximum Duty Cycle  |             | AX3051                              | 90   | 93  | -    | %           |
|   |             | AX3051A                             | 87   | 90  | -    | %           |
| Minimum On-Time   |             |                                     | -    | 150 | -    | ns          |
| Secondary Cycle-by-Cycle Current Limit                      |             | Minimum Duty Cycle, no CC           | -    | 3.5 | -    | A           |
| Reference Voltage of the Short Circuit Fold back Comparator | $V_{SCP}$   |                                     | -    | 0.4 | 0.45 | V           |
| Sense Voltage (Bin2)  | $V_{SENSE}$ | $V_{SENSE1}-V_{SENSE2}$             | 95   | 100 | 105  | mV          |
| Sense Voltage (Bin3)  | $V_{SENSE}$ | $V_{SENSE1}-V_{SENSE2}$             | 85   | 100 | 115  | mV          |
| Thermal shutdown Temp                                       | $T_{SD}$    |                                     | -    | 140 | -    | $^{\circ}C$ |
| Thermal Shutdown Hysteresis                                 | $T_{SH}$    |                                     | -    | 30  | -    | $^{\circ}C$ |

❖ **APPLICATION CIRCUIT**

**AL CAPACITOR**

(1) Frequency=100KHz

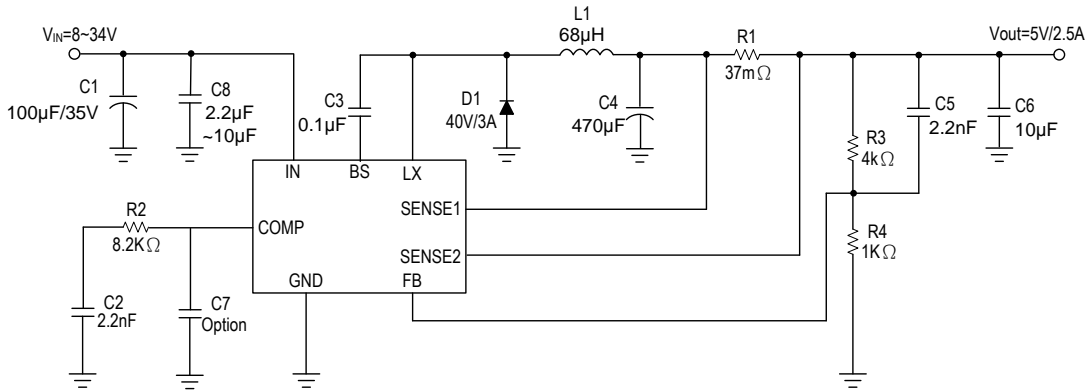

(2) Frequency=250KHz

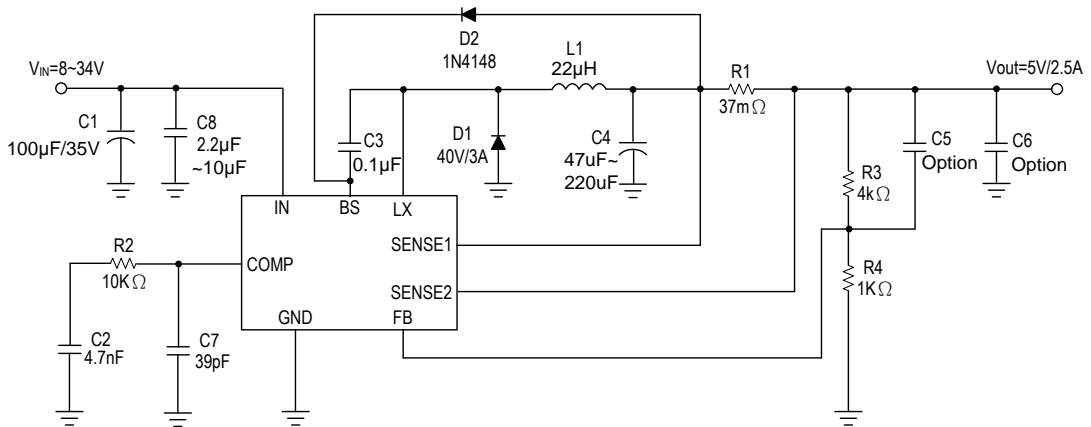

## ❖ FUNCTION DESCRIPTIONS

### CV/CC Loop Regulation

As seen in Functional Block Diagram, the AX3051/A is a peak current mode pulse width modulation (PWM) converter with CC and CV control. The converter operates as follows:

A switching cycle starts when the rising edge of the Oscillator clock output causes the High-Side Power Switch to turn on. With the LX side of the inductor now connected to Sense1, the inductor current ramps up to store energy in the magnetic field. The inductor current level is measured by the Current Sense Amplifier and added to the Oscillator ramp signal. If the resulting summation is higher than the COMP voltage, the output of the PWM Comparator goes high. When this happens or when Oscillator clock output goes low, the High-Side Power Switch turns off.

At this point, the LX side of the inductor swings to a diode voltage below ground, causing the inductor current to decrease and magnetic energy to be transferred to output. This state continues until the cycle starts again. The High-Side Power Switch is driven by logic using BS as the positive rail. This pin is charged to  $V_{LX} + 5V$  when the Low-Side Power Switch turns on. The COMP voltage is the integration of the error between FB input and the internal 1V reference. If FB is lower than the reference voltage, COMP tends to go higher to increase current to the output. Output current will increase until it reaches the CC limit set by the R1 resistor. At this point, the device will transition from regulating output voltage to regulating output current, and the output voltage will drop with increasing load.

### Current Limit Protection

The Current limit is set by outside resistance ( $R_{SENSE}$ ), When the SENSE1-SENSE2 voltage larger than 100mV, the current limit is happened that driver can be turned off. The current limit set according to the following equation:

$$\text{Current Limit (A)} = \frac{100\text{mV}}{R_{SENSE}}$$

### Output Over-Voltage protection

The AX3051/A provides output over-voltage protection function. When output over-voltage happens ( $V_{\text{SENS2}} > 5.8\text{V}$ ), the AX3051/A shuts down. When output over-voltage is released ( $V_{\text{SENS2}} < 5.7\text{V}$ ), the AX3051/A recovers to normal state automatically.

### Output Short-Circuit protection

The AX3051/A provides output short-circuit protection function. When  $V_{\text{OUT}}$  is short ( $V_{\text{FB}} < 0.4\text{V}$ ), the auto restart function can be started that restart the regulator cycle by cycle. The cycle time is set by internal counter.

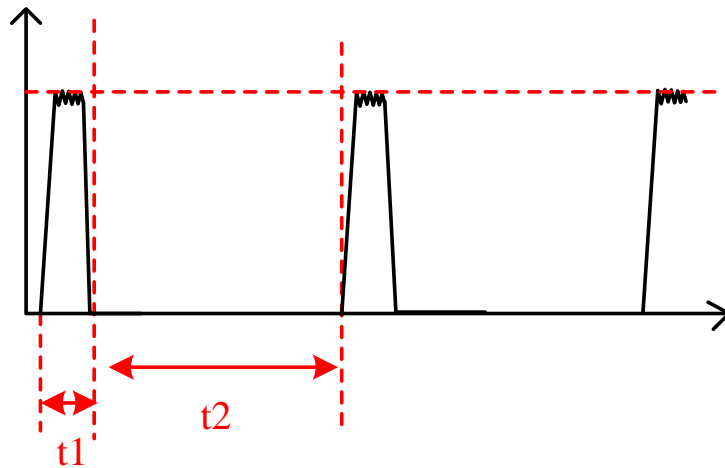

$$t_1 = 3m(\text{Sec.})$$

$$t_2 = 90m(\text{Sec.})$$

### Thermal Shutdown

The AX3051/A disables switching when its junction temperature exceeds  $140^{\circ}\text{C}$  and resumes when the temperature has dropped by  $30^{\circ}\text{C}$ .



❖ APPLICATION INFORMATION

Output Voltage Setting

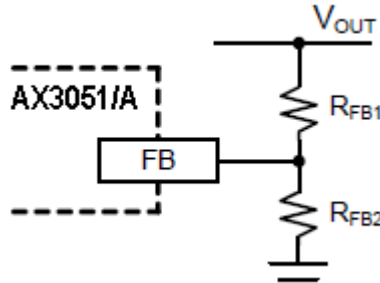

Figure1 Output Voltage Setting

Figure 1 shows the connections for setting the output voltage. Select the proper ratio of the two feedback resistors RFB1 and RFB2 based on the output voltage. Typically, use  $R_{FB2} \approx 10k\Omega$  and determine RFB1 from the following equation:

$$R_{FB1} = R_{FB2} \left( \frac{V_{OUT}}{1V} - 1 \right)$$

Inductor Selection

The inductor maintains a continuous current to the output load. This inductor current has a ripple that is dependent on the inductance value:

Higher inductance reduces the peak-to-peak ripple current. The trade off for high inductance value is the increase in inductor core size and series resistance, and the reduction in current handling capability. In general, select an inductance value L based on ripple current requirement:

$$L = \frac{V_{OUT} \times (V_{IN} - V_{OUT})}{V_{IN} f_{LX} I_{OUTMAX} K_{RIPPLE}}$$

where  $V_{IN}$  is the input voltage,  $V_{OUT}$  is the output voltage,  $f_{LX}$  is the switching frequency,  $I_{OUTMAX}$  is the maximum output current, and  $K_{RIPPLE}$  is the ripple factor. Typically, choose  $K_{RIPPLE} = 30\%$  to correspond to the peak-to-peak ripple current being 30% of the maximum output current.

With this inductor value, the peak inductor current is  $I_{OUT} \times (1 + K_{RIPPLE}/2)$ . Make sure that this peak inductor current is less than the controller's current limit. Finally, select the inductor core size so that it does not saturate at the peak inductor current.

## Input Capacitor

The input capacitor needs to be carefully selected to maintain sufficiently low ripple at the supply input of the converter. A low ESR capacitor is highly recommended. Since large current flows in and out of this capacitor during switching, its ESR also affects efficiency.

The input capacitance needs to be higher than 100μF. The best choice is the ceramic type, however, low ESR tantalum or electrolytic types may also be used provided that the RMS ripple current rating is higher than 50% of the output current. The input capacitor should be placed close to the IN and G pins of the IC, with the shortest traces possible. In the case of tantalum or electrolytic types, they can be further away if a small parallel 0.1μF ceramic capacitor is placed right next to the IC. Especially C8 capacitor should be placed as close as possible to the IC pin.

## Output Capacitor

The output capacitor also needs to have low ESR to keep low output voltage ripple. The output ripple voltage is:

$$V_{\text{RIPPLE}} = I_{\text{OUTMAX}} K_{\text{RIPPLE}} R_{\text{ESR}} + \frac{V_{\text{IN}}}{28 \times f_{\text{LX}}^2 L C_{\text{OUT}}}$$

where  $I_{\text{OUTMAX}}$  is the maximum output current,  $K_{\text{RIPPLE}}$  is the ripple factor,  $R_{\text{ESR}}$  is the ESR of the output capacitor,  $f_{\text{LX}}$  is the switching frequency,  $L$  is the inductor value, and  $C_{\text{OUT}}$  is the output capacitance. In the case of ceramic output capacitors,  $R_{\text{ESR}}$  is very small and does not contribute to the ripple. Therefore, a lower capacitance value can be used for ceramic type. In the case of tantalum or electrolytic capacitors, the ripple is dominated by  $R_{\text{ESR}}$  multiplied by the ripple current. In that case, the output capacitor is chosen to have sufficiently low ESR.

For ceramic output capacitor, typically choose a capacitance of about 470μF. For tantalum or electrolytic capacitors, choose a capacitor with less than 50mΩ ESR.

### Rectifier Diode

Use a Schottky diode as the rectifier to conduct current when the High-Side Power Switch is off.

The Schottky diode must have current rating higher than the maximum output current and a reverse voltage rating higher than the maximum input voltage.

### Output Cable Resistance Compensation

To compensate for resistive voltage drop across the charger's output cable, the AX3051/A integrates a simple, user-programmable cable voltage drop compensation using the impedance at the FB pin. Use the curve in Figure 2 to choose the proper feedback resistance values for cable compensation.  $R_{FB1}$  is the high side resistor of voltage divider.

$$V_{OUT} = \left[ \left( 1 + \frac{R_{FB1}}{R_{FB2}} \right) \times V_{FB} \right] + R_{FB1} \times I_{FB}$$

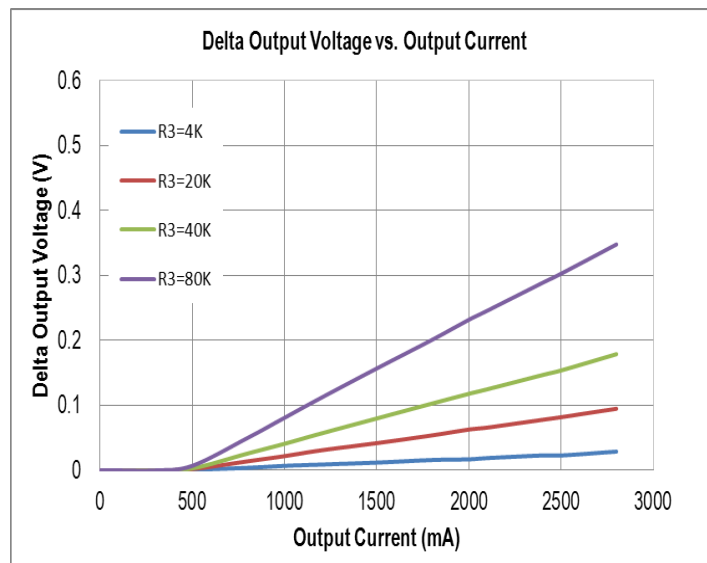
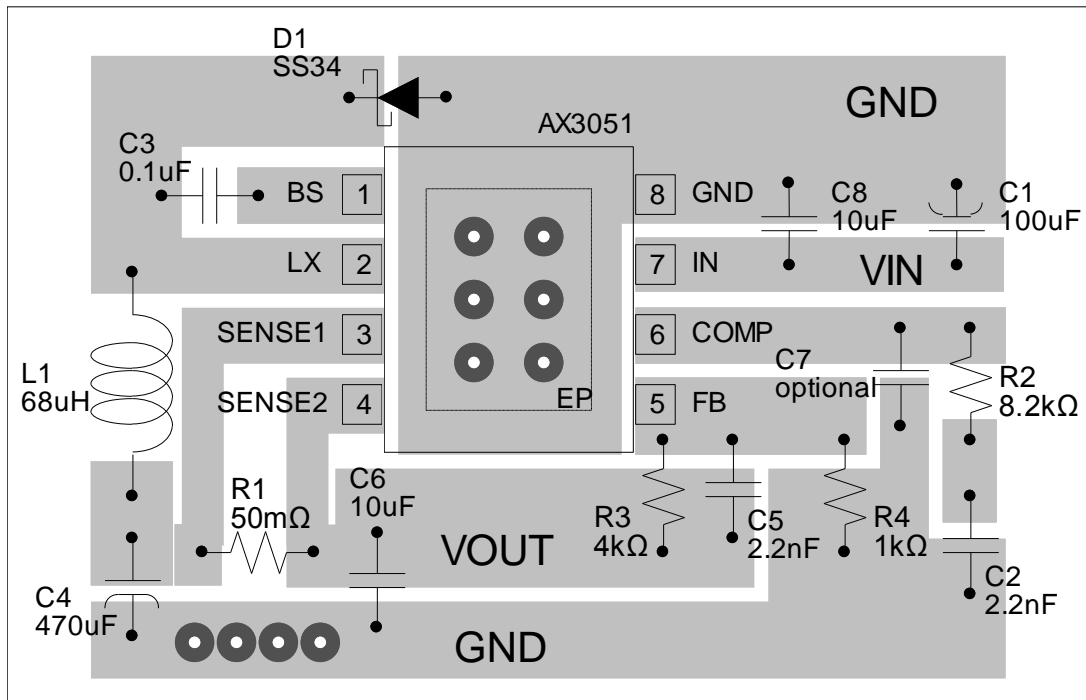

Figure2 Cable Compensation at Various Resistor Divider Values

Layout Guide



Recommended layout guidelines are as follows:

1. Connect the 10 $\mu$ F VIN bypass capacitor next to the IN pin with a short return to the GND pin.
2. Keep the BS to LX bypass capacitor near both pins as it provides the internal high-side FET gate driver.
3. Keep the LX traces as short as is practically possible as these carry high peak currents to decrease the EMI issue.
4. Carefully connect the noise sensitive signals such as FB, COMP, SENSE1 and SENSE2 as close to the IC as practically possible.
5. SENSE1 and SENSE2 should be connected to R1 resistor directly to provide accurate current sensing.
6. The Exposed Pad (EP) should be connected to any internal PCB ground planes using multiple vias directly under the IC for best thermal performance.

❖ **TYPICAL CHARACTERISTICS**

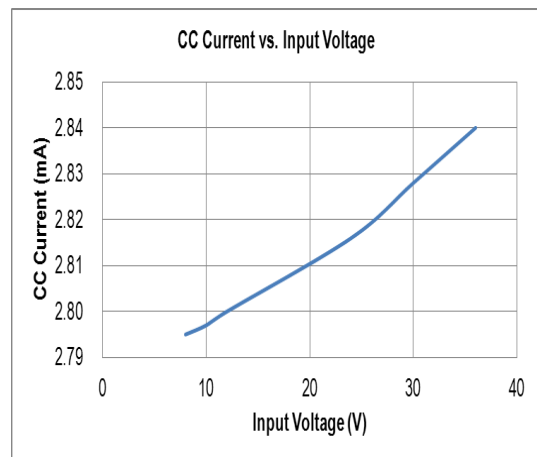
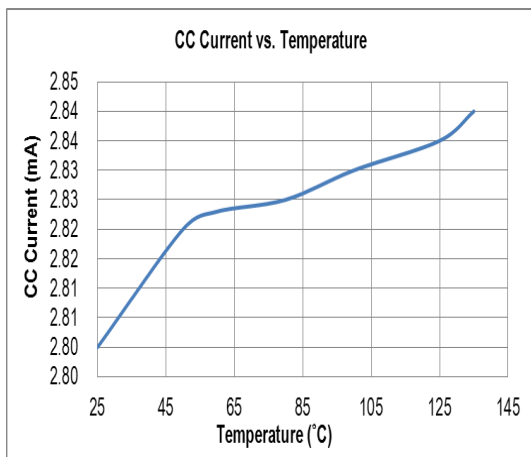
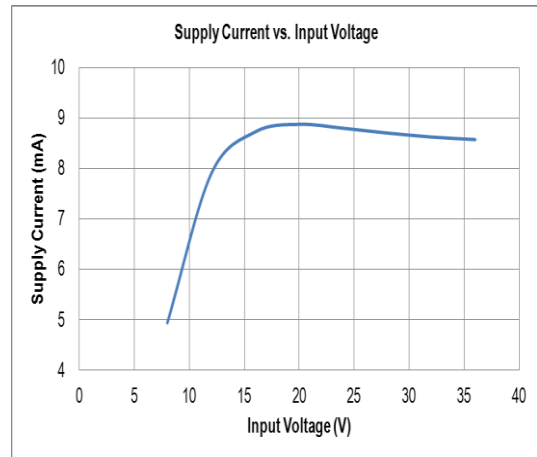
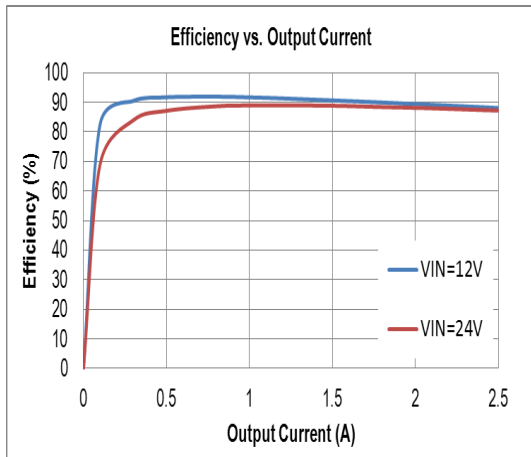
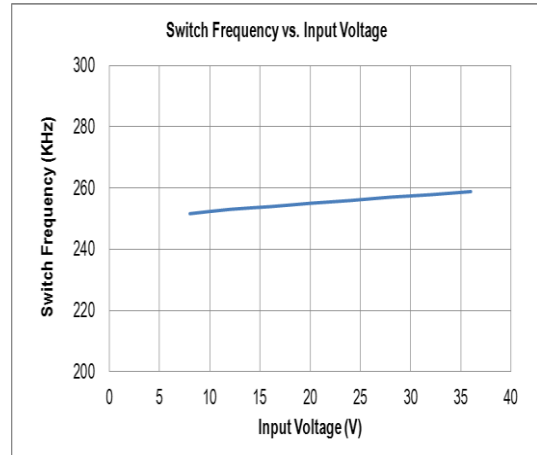
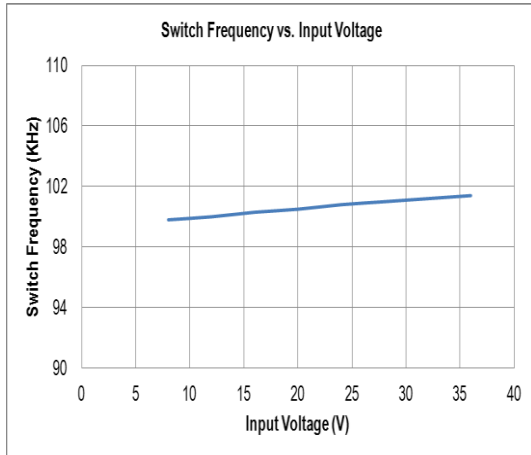

**❖ TYPICAL CHARACTERISTICS (CONTINUES)**

Start up into CC mode

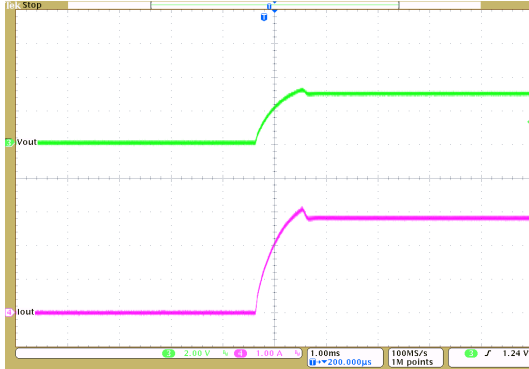
 $V_{IN}=12V, V_{OUT}=5V, I_{OUT}=2.8A$ 

Start up into CC mode

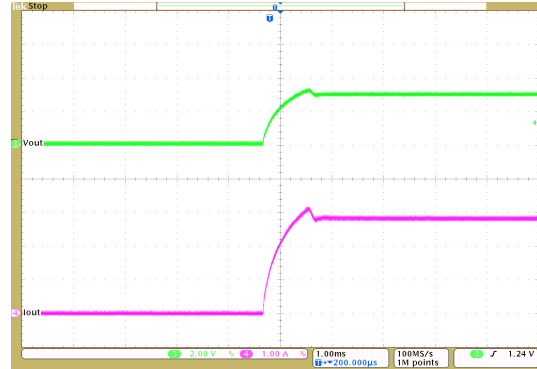
 $V_{IN}=24V, V_{OUT}=5V, I_{OUT}=2.8A$ 

Transient Response (Rising Time)

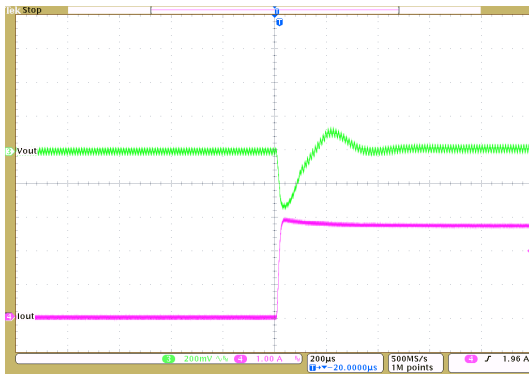
 $V_{IN}=12V, V_{OUT}=5V, I_{OUT}=0.01A\sim 2.8A$ 

Transient Response (Falling Time)

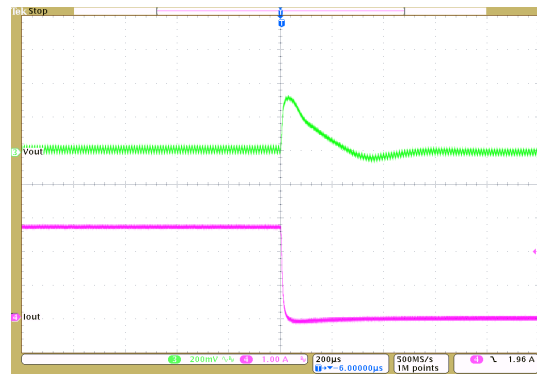
 $V_{IN}=12V, V_{OUT}=5V, I_{OUT}=0.01A\sim 2.8A$ 

Transient Response (Rising Time)

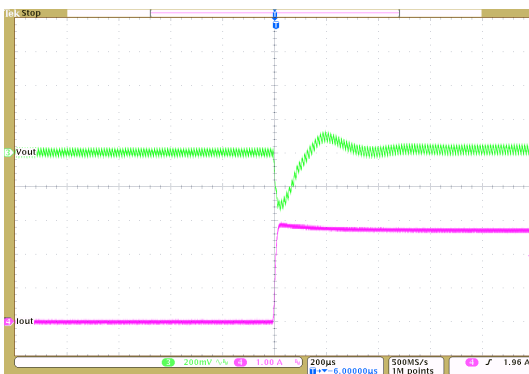
 $V_{IN}=24V, V_{OUT}=5V, I_{OUT}=0.01A\sim 2.8A$ 

Transient Response (Falling Time)

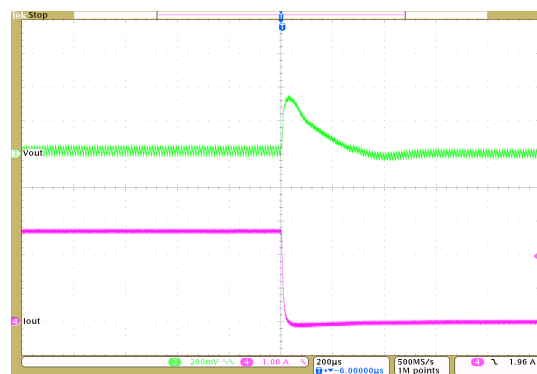
 $V_{IN}=24V, V_{OUT}=5V, I_{OUT}=0.01A\sim 2.8A$ 

❖ TYPICAL CHARACTERISTICS (CONTINUES)

Short Circuit  
 $V_{IN}=12V, V_{OUT}=5V$



Short Circuit  
 $V_{IN}=24V, V_{OUT}=5V$

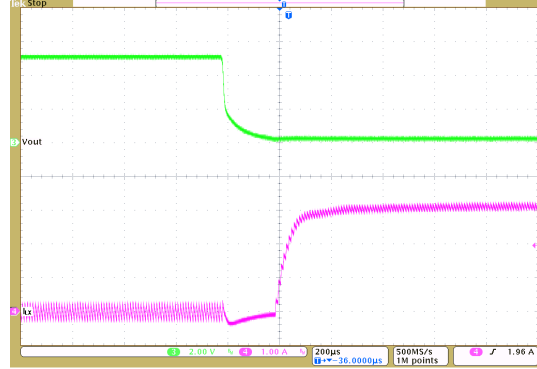

Output Voltage Ripple  
 $V_{IN}=12V, V_{OUT}=5V, I_{OUT}=2.8A$

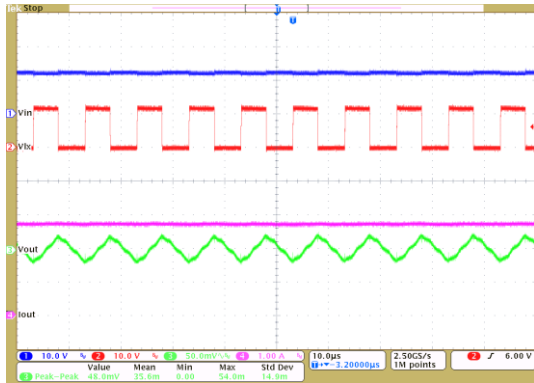

Output Voltage Ripple  
 $V_{IN}=24V, V_{OUT}=5V, I_{OUT}=2.8A$

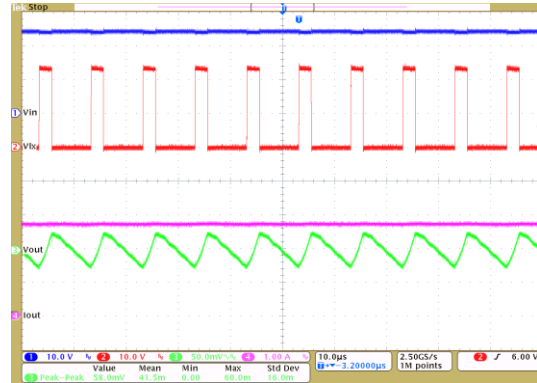

❖ **PACKAGE OUTLINES**

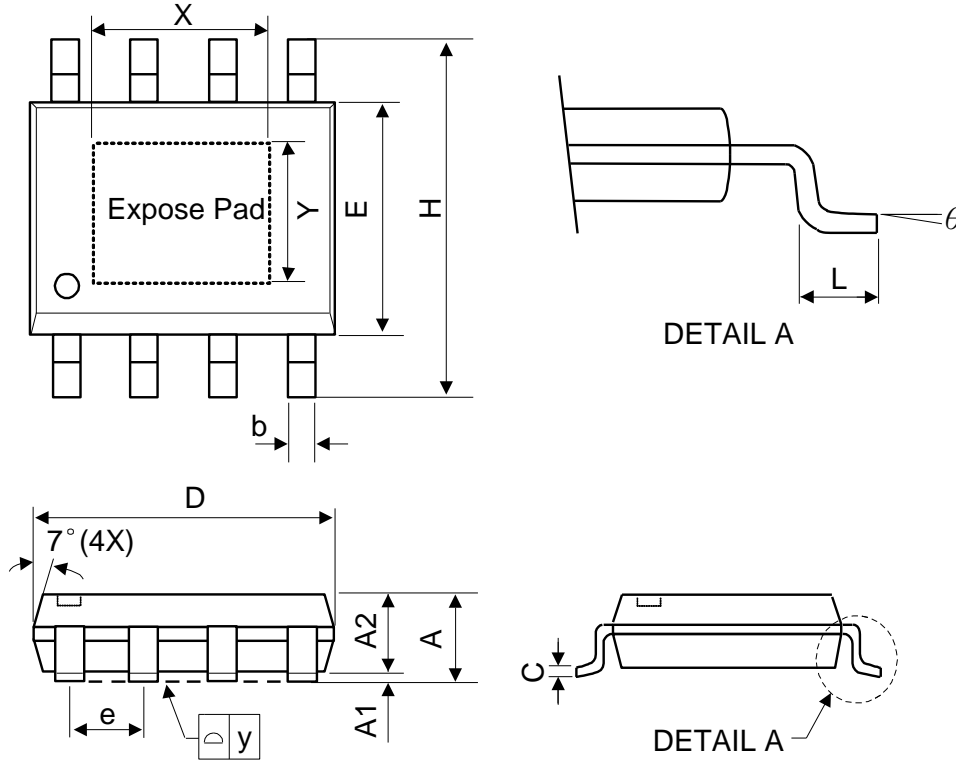

| Symbol | Dimensions in Millimeters |      |      | Dimensions in Inches |       |       |
|--------|---------------------------|------|------|----------------------|-------|-------|
|        | Min.                      | Nom. | Max. | Min.                 | Nom.  | Max.  |
| A      | -                         | -    | 1.75 | -                    | -     | 0.069 |
| A1     | 0                         | -    | 0.15 | 0                    | -     | 0.06  |
| A2     | 1.25                      | -    | -    | 0.049                | -     | -     |
| C      | 0.1                       | 0.2  | 0.25 | 0.0075               | 0.008 | 0.01  |
| D      | 4.7                       | 4.9  | 5.1  | 0.185                | 0.193 | 0.2   |
| E      | 3.7                       | 3.9  | 4.1  | 0.146                | 0.154 | 0.161 |
| H      | 5.8                       | 6    | 6.2  | 0.228                | 0.236 | 0.244 |
| L      | 0.4                       | -    | 1.27 | 0.015                | -     | 0.05  |
| b      | 0.31                      | 0.41 | 0.51 | 0.012                | 0.016 | 0.02  |
| e      | 1.27 BSC                  |      |      | 0.050 BSC            |       |       |
| y      | -                         | -    | 0.1  | -                    | -     | 0.004 |
| X      | -                         | 2.34 | -    | -                    | 0.092 | -     |
| Y      | -                         | 2.34 | -    | -                    | 0.092 | -     |
| θ      | 0°                        | -    | 8°   | 0°                   | -     | 8°    |

Mold flash shall not exceed 0.25mm per side  
JEDEC outline: MS-012 BA



❖ Carrier tape dimension

ESOP8L

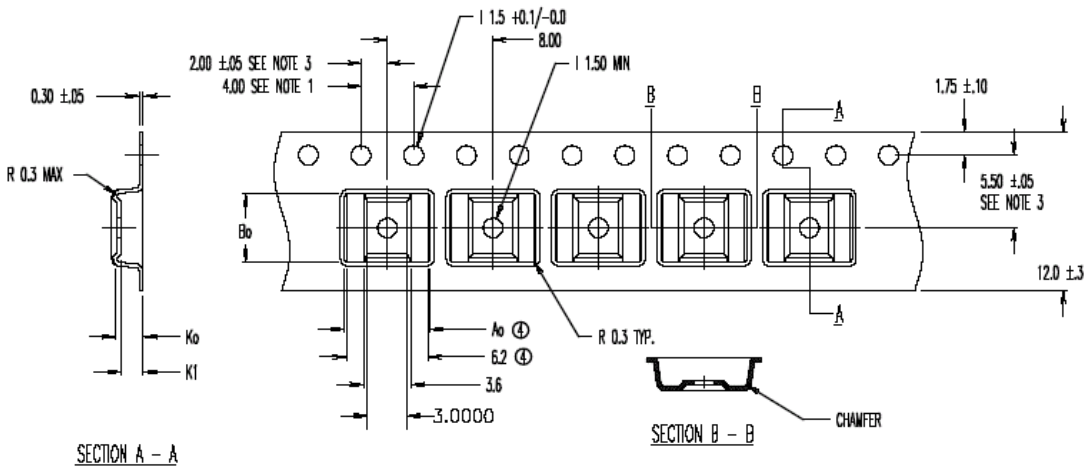
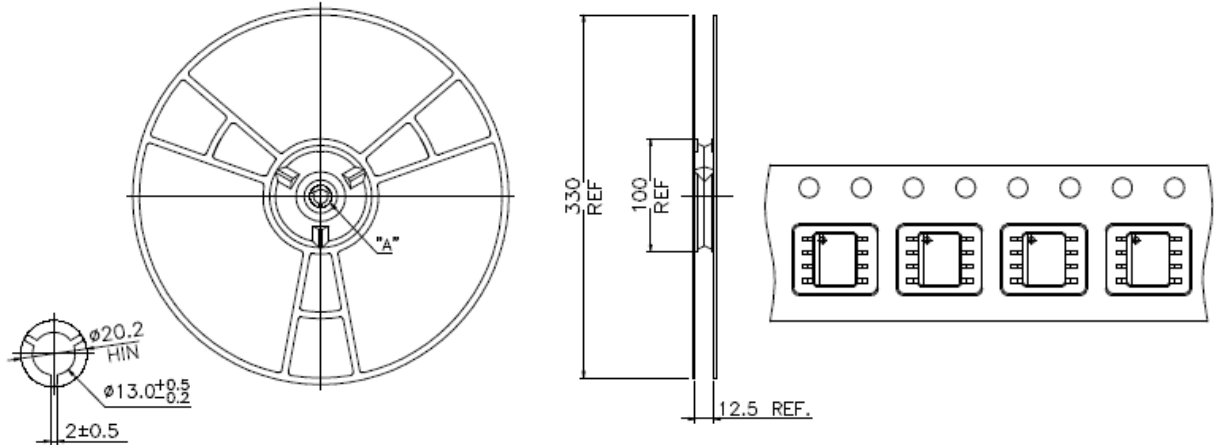

ⓈⓈ  $A_0 = 6.50$   
 $B_0 = 5.20$   
 $K_0 = 2.10$   
 $K_1 = 1.70$

Notes:

1. 10 sprocket hole pitch cumulative tolerance  $\pm 0.2\text{mm}$
2. Camber not to exceed 1mm in 100mm.
3. Material: Anti-Static Black Advantek Polystyrene.
4.  $A_0$  and  $B_0$  measured on a plane 0.3mm above the bottom of the pocket.
5.  $K_0$  measured from a plane on the inside bottom of the pocket to the top surface of the carrier.
6. Pocket position relative to sprocket hole measured as true position of pocket, not pocket hole.