

3-Pin Microprocessor Reset Circuits

❖ GENERAL DESCRIPTION

The AX6901/2/3/4 is used for microprocessor (μ P) supervisory circuits to monitor the power supplies in μ P and digital systems. They provide excellent circuit reliability and low cost by eliminating external components and adjustments when used with +5V, +3.3V, +3.0V, +2.5V powered circuits.

These circuits perform a single function: they assert a reset signal whenever the VCC supply voltage declines below a preset threshold, keeping it asserted for at least 200ms after VCC has risen above the reset threshold. Reset thresholds suitable for operation with a variety of supply voltages are available. The AX6901/2/3/4 has push pull outputs. The AX6901/3 has an active low $\overline{\text{RESET}}$ output, while the AX6902/4 has an active high RESET output. The reset comparator is designed to ignore fast transients on VCC, and the outputs are guaranteed to be in the correct logic state for VCC down to 1.0V. Low supply current makes the AX6901/2/3/4 ideal for use in portable equipment. The AX6901/2/3/4 is available in a 3-pin SOT23 and SC70 package.

❖ FEATURES

- Precision Monitoring of +2.5,+3V, +3.3V, and +5V Power-Supply Voltages
- Fully Specified Over Temperature
- Available in Three Output Configurations
- Push-Pull $\overline{\text{RESET}}$ Low Output(AX6901/3)
- Push-Pull RESET High Output(AX6902/4)
- 200ms (Typ.)min Power-On Reset Pulse Width
- 25 μ A Supply Current
- Guaranteed Reset Valid to $V_{CC} = +1.0V$
- Power Supply Transient Immunity
- No External Components
- Available in the 3-Pin Pb-Free SOT-23 and SC70 Package

❖ BLOCK DIAGRAM

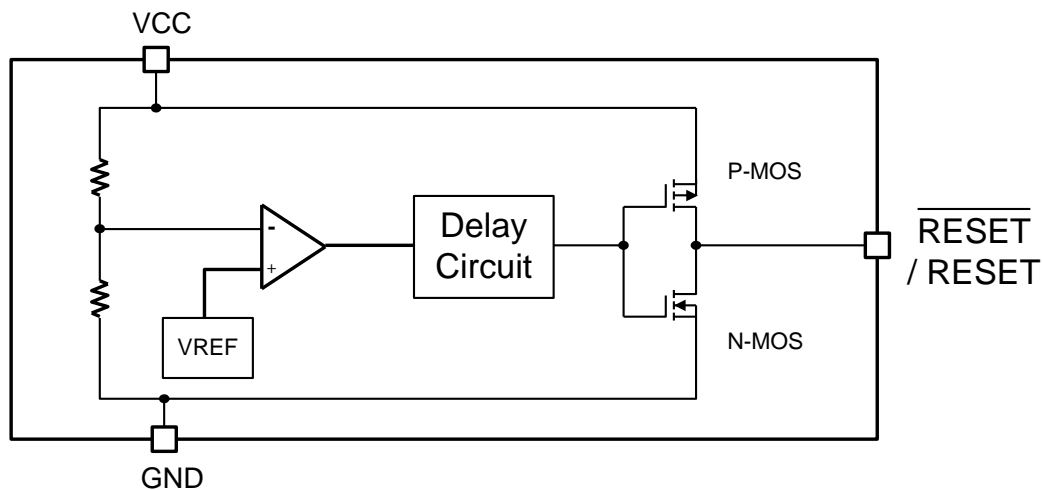

❖ **PIN ASSIGNMENT**

The packages of AX6901/2/3/4 are SOT-23-3L and SC70-3L; the pin assignment is given by:

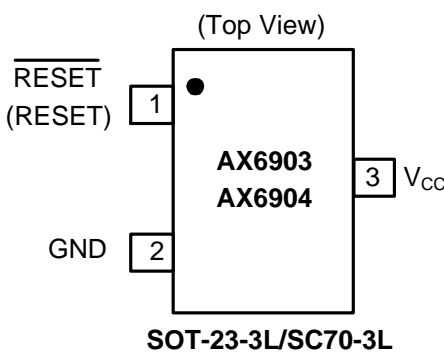
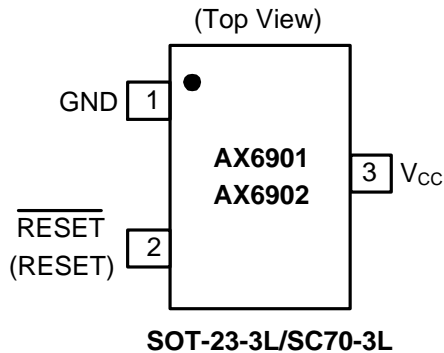

Name	Description
GND	Ground
RESET (RESET)	Reset output pin L: for AX6901/3 H: for AX6902/4
V_{cc}	Operating voltage input

❖ **ORDER/MARKING INFORMATION**

Order Information	
AX690 X X X X <div style="display: flex; justify-content: space-around;"> <div style="border: 1px solid black; padding: 2px;">Enable</div> <div style="border: 1px solid black; padding: 2px;">Voltage</div> <div style="border: 1px solid black; padding: 2px;">Package</div> <div style="border: 1px solid black; padding: 2px;">Packing</div> </div>	
<div style="display: flex; justify-content: space-between;"> <div style="width: 25%;"> 1: Active-Low 2: Active-High 3: Active-Low 4: Active-High </div> <div style="width: 25%;"> A: 4.63 B: 4.38 C: 4.00 D: 3.08 E: 2.93 F: 2.63 G: 2.25 H: 2.70 I : 4.25 J: 2.80 </div> <div style="width: 25%;"> A: SC70-3L R: SOT23-3L </div> <div style="width: 25%;"> Blank : Bag A : Taping </div> </div>	
Top Marking (SOT-23-3L)	Top Marking (SC70-3L)
<p>LLYWX → ID Code: internal</p> <p> WW : 01~26(A~Z) 27~52(a~z)</p> <p> Year : A = 2010 1 = 2011</p> <p> Identification code</p>	<p>LLYW → WW : 01~26(A~Z) 27~52(a~z)</p> <p> ID Code: internal</p> <p> Year : A = 2010 1 = 2011</p> <p> Identification code</p>

Appendix

Part Number	Package	Identification Code	Part Number	Package	Identification Code
AX6901A	SOT-23-3L	CA	AX6903A	SOT-23-3L	CO
AX6901B	SOT-23-3L	CB	AX6903B	SOT-23-3L	CP
AX6901C	SOT-23-3L	CC	AX6903C	SOT-23-3L	CQ
AX6901D	SOT-23-3L	CD	AX6903D	SOT-23-3L	CR
AX6901E	SOT-23-3L	CE	AX6903E	SOT-23-3L	CS
AX6901F	SOT-23-3L	CF	AX6903F	SOT-23-3L	CT
AX6901G	SOT-23-3L	CG	AX6903G	SOT-23-3L	CU
AX6901H	SOT-23-3L	Ca	AX6903H	SOT-23-3L	Cf
AX6901I	SOT-23-3L	Cb	AX6903I	SOT-23-3L	Cg
AX6901J	SOT-23-3L	Ci	AX6903J	SOT-23-3L	Cj
AX6902A	SOT-23-3L	CH	AX6904A	SOT-23-3L	C1
AX6902B	SOT-23-3L	CI	AX6904B	SOT-23-3L	C2
AX6902C	SOT-23-3L	CJ	AX6904C	SOT-23-3L	C3
AX6902D	SOT-23-3L	CK	AX6904D	SOT-23-3L	C4
AX6902E	SOT-23-3L	CL	AX6904E	SOT-23-3L	C5
AX6902F	SOT-23-3L	CM	AX6904F	SOT-23-3L	C6
AX6902G	SOT-23-3L	CN	AX6904G	SOT-23-3L	C7
AX6902H	SOT-23-3L	Cd	AX6904H	SOT-23-3L	Ch
AX6902I	SOT-23-3L	Ce	AX6904I	SOT-23-3L	Cm
AX6902J	SOT-23-3L	Ck	AX6904J	SOT-23-3L	Cn
AX6901A	SC70-3L	a	AX6903A	SC70-3L	o
AX6901B	SC70-3L	b	AX6903B	SC70-3L	p
AX6901C	SC70-3L	c	AX6903C	SC70-3L	q
AX6901D	SC70-3L	d	AX6903D	SC70-3L	r
AX6901E	SC70-3L	e	AX6903E	SC70-3L	s
AX6901F	SC70-3L	f	AX6903F	SC70-3L	t
AX6901G	SC70-3L	g	AX6903G	SC70-3L	u
AX6901H	SC70-3L	3	AX6903H	SC70-3L	7
AX6901I	SC70-3L	4	AX6903I	SC70-3L	8
AX6901J	SC70-3L	A	AX6903J	SC70-3L	B
AX6902A	SC70-3L	h	AX6904A	SC70-3L	v
AX6902B	SC70-3L	i	AX6904B	SC70-3L	w
AX6902C	SC70-3L	j	AX6904C	SC70-3L	x
AX6902D	SC70-3L	k	AX6904D	SC70-3L	y
AX6902E	SC70-3L	l	AX6904E	SC70-3L	z
AX6902F	SC70-3L	m	AX6904F	SC70-3L	1
AX6902G	SC70-3L	n	AX6904G	SC70-3L	2
AX6902H	SC70-3L	5	AX6904H	SC70-3L	9
AX6902I	SC70-3L	6	AX6904I	SC70-3L	0
AX6902J	SC70-3L	D	AX6904J	SC70-3L	E

❖ ABSOLUTE MAXIMUM RATINGS (at $T_A=25^{\circ}\text{C}$)

Characteristics	Symbol	Rating	Unit
VCC Pin Voltage	V_{CC}	GND - 0.3 to GND + 6.5	V
RESET, $\overline{\text{RESET}}$ (push-pull) Pin Voltage	V_{RESET}	GND - 0.3 to $V_{CC} + 0.3$	V
Input Current, V_{CC}	I_{CC}	20	mA
Output Current, RESET, $\overline{\text{RESET}}$	I_O	5	mA
Power Dissipation	PD	$(T_J - T_A) / \theta_{JA}$	mW
Storage Temperature Range	T_{ST}	-60 to +150	$^{\circ}\text{C}$
Operating Temperature Range	T_{OP}	-40 to +85	$^{\circ}\text{C}$
Junction Temperature	T_J	-40 to +150	$^{\circ}\text{C}$
Thermal Resistance from Junction to case	θ_{JC}	110	$^{\circ}\text{C}/\text{W}$
Thermal Resistance from Junction to ambient	θ_{JA}	250	$^{\circ}\text{C}/\text{W}$

Note: θ_{JA} is measured with the PCB copper area of approximately 1 in²(Multi-layer). That need connect to V_{SS} pin.

❖ ELECTRICAL CHARACTERISTICS $T_A=25^{\circ}\text{C}$ (unless otherwise noted)

Characteristics	Symbol	Conditions	Min	Typ	Max	Units
Operating V_{CC} Range	V_{Range}		1.0	-	6	V
Supply Current	I_{CC}	$V_{CC} = V_{TH} + 1.0\text{V}$	-	25	35	μA
Reset Threshold $T_A=25^{\circ}\text{C}$	V_{TH}	AX6901/2/3/4A	4.54	4.63	4.71	V
		AX6901/2/3/4B	4.29	4.38	4.46	
		AX6901/2/3/4I	4.16	4.25	4.33	
		AX6901/2/3/4C	3.92	4.00	4.08	
		AX6901/2/3/4D	3.02	3.08	3.15	
		AX6901/2/3/4E	2.87	2.93	3.00	
		AX6901/2/3/4H	2.64	2.70	2.75	
		AX6901/2/3/4F	2.57	2.63	2.69	
AX6901/2/3/4G	2.20	2.25	2.30			
Reset Threshold Tempco	V_{THT}	$T_A = 0^{\circ}\text{C}$ to $+85^{\circ}\text{C}$	-	50	-	ppm/ $^{\circ}\text{C}$
Set-up Time	T_S	$V_{CC} = 0$ to $(V_{TH} - 100\text{mV})$	1	-	-	μs
V_{CC} to Reset Delay	T_{RD}	$V_{CC} = V_{TH}$ to $(V_{TH} - 100\text{mV})$	-	20	-	μs
Reset Active Timeout Period	T_{DELAY}	$T_A = 0^{\circ}\text{C}$ to $+85^{\circ}\text{C}$	160	200	260	ms
$\overline{\text{RESET}}$ Output Voltage (AX6901/3)	V_{OL}	$1.8\text{V} < V_{CC} < V_{TH(\text{min})}$, $I_{\text{SINK}} = 1.2\text{mA}$	-	-	0.3	V
		$1.2\text{V} < V_{CC} < 1.8\text{V}$, $I_{\text{SINK}} = 50\mu\text{A}$				
	V_{OH}	$V_{CC} > V_{TH(\text{max})}$, $I_{\text{SOURCE}} = 500\mu\text{A}$,	$0.8V_{CC}$	-	-	V
RESET Output Voltage (AX6902/4)	V_{OL}	$V_{CC} > V_{TH(\text{max})}$, $I_{\text{SINK}} = 1.2\text{mA}$,	-	-	0.3	V
		$1.8\text{V} < V_{CC} < V_{TH(\text{min})}$, $I_{\text{SOURCE}} = 500\mu\text{A}$	0.8	-	-	
	V_{OH}	$1.2\text{V} < V_{CC} < 1.8\text{V}$, $I_{\text{SOURCE}} = 150\mu\text{A}$	V_{CC}	-	-	V
Hysteresis at V_{CC}	V_{Hys}	Input voltage	-	40	-	mV

❖ APPLICATION CIRCUIT

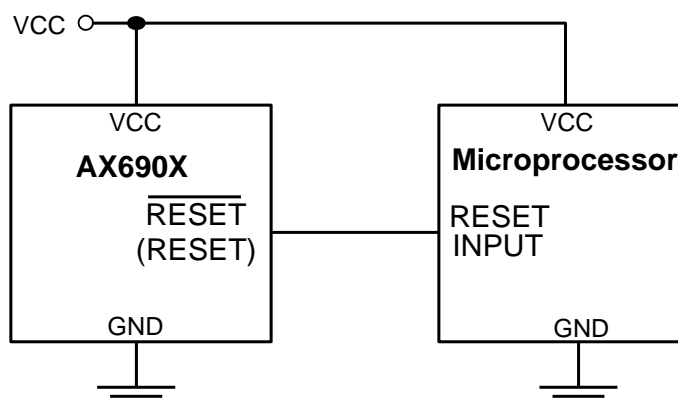

❖ FUNCTION DESCRIPTIONS

A microprocessor's (μP 's) reset input starts the μP in a known state. The AX6901/2/3/4 asserts reset to prevent code-execution errors during power-up, power-down, or brownout conditions. They assert a reset signal whenever the VCC supply voltage declines below a preset threshold, keeping it asserted for at least 200ms after VCC has risen above the reset threshold. The AX6901/2/3/4 has a push-pull output stage.

❖ APPLICATION INFORMATION

Negative-Going VCC Transients

In addition to issuing a reset to the μP during power-up, power-down, and brownout conditions, the AX6901/2/3/4 is relatively immune to short-duration negative-going VCC transients (glitches).

The AX6901/2/3/4 does not generate a reset pulse. The graph was generated using a negative going pulse applied to VCC, starting 0.5V above the actual reset threshold and ending below it by the magnitude indicated (reset comparator overdrive). The graph indicates the maximum pulse width a negative going VCC transient can have without causing a reset pulse. As the magnitude of the transient increases (goes farther below the reset threshold), the maximum allowable pulse width decreases. Typically, a VCC transient that goes 50mV below the reset threshold A 0.1 μF bypass capacitor mounted as close as possible to the VCC pin provides additional transient immunity.

Ensuring a Valid Reset Output Down to VCC = 0

$\overline{\text{RESET}}$ is guaranteed to be a logic low for VCC > 1.0V. Once VCC exceeds the reset threshold, an internal timer keeps $\overline{\text{RESET}}$ low for the reset timeout period; after this interval, $\overline{\text{RESET}}$ goes high. If a brownout condition occurs (VCC dips below the reset threshold), $\overline{\text{RESET}}$ goes low. Any time VCC goes below the reset threshold, the internal timer resets to zero, and $\overline{\text{RESET}}$ goes low. The internal timer starts after VCC returns above the reset threshold, and $\overline{\text{RESET}}$ remains low for the reset timeout period.

When VCC falls below 1.0V, the AX6901/3 RESET output no longer sinks current—it becomes an open circuit. Therefore, high-impedance CMOS logic inputs connected to $\overline{\text{RESET}}$ can drift to undetermined voltages.

This presents no problem in most applications since most μP and other circuitry is inoperative with VCC below 1.0V. However, in applications where $\overline{\text{RESET}}$ must be valid down to 0V, adding a pull down resistor to $\overline{\text{RESET}}$ causes any stray leakage currents to flow to ground, holding $\overline{\text{RESET}}$ low. R1's value is not critical; 100k is large enough not to load $\overline{\text{RESET}}$ and small enough to pull $\overline{\text{RESET}}$ to ground. For the AX6902/4 if RESET is required to remain valid for VCC < 1.0V.

Benefits of Highly Accurate Reset Threshold

Most μP supervisor ICs has reset threshold voltages between 5% and 10% below the value of nominal supply voltages. This ensures a reset will not occur within 5% of the nominal supply, but will occur when the supply is 10% below nominal. When using ICs rated at only the nominal supply $\pm 5\%$, this leaves a zone of uncertainty where the supply is between 5% and 10% low, and where the reset may or may not be asserted.

❖ TYPICAL CHARACTERISTICS

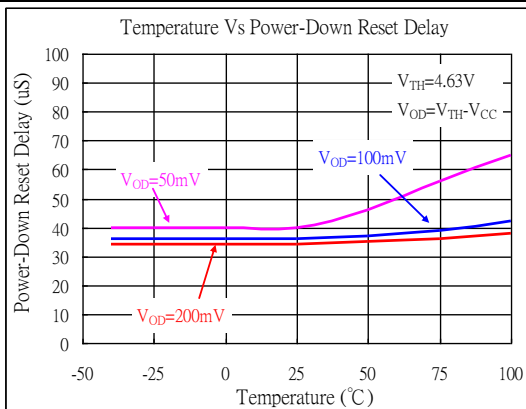
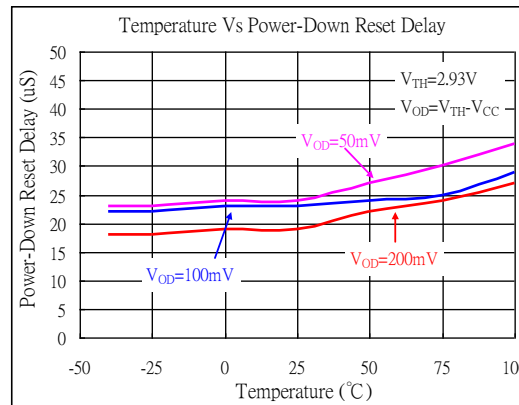
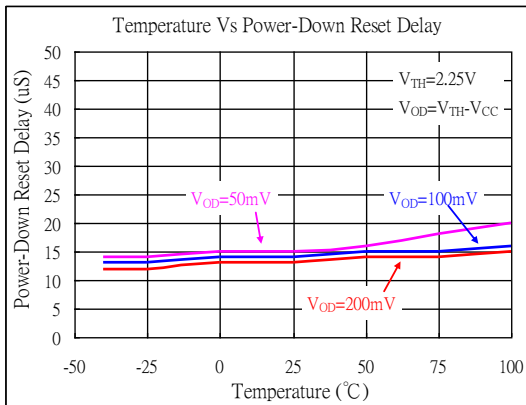
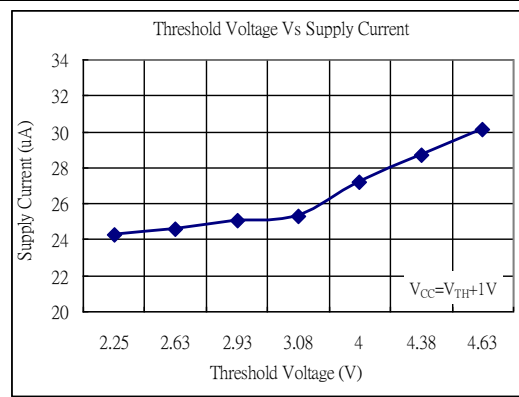
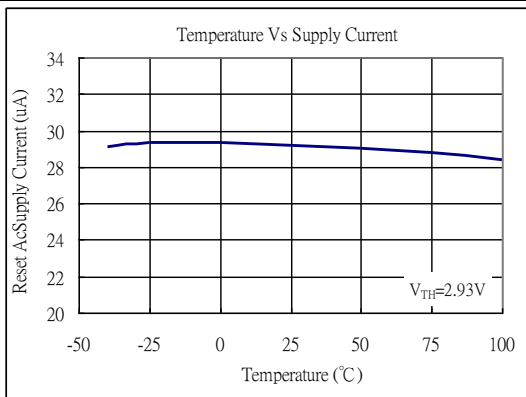
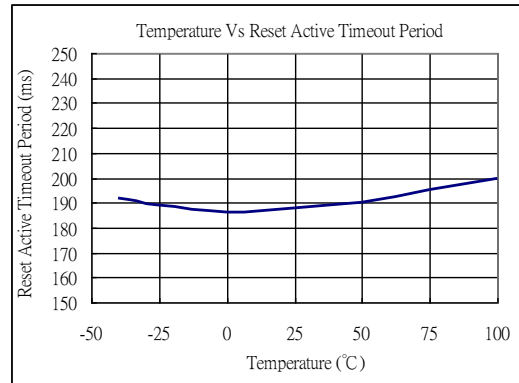
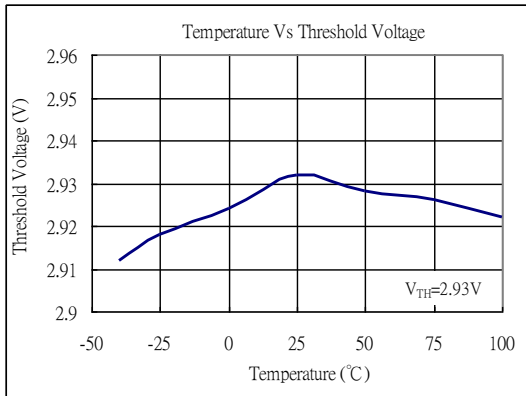

❖ TIMING DIAGRAM

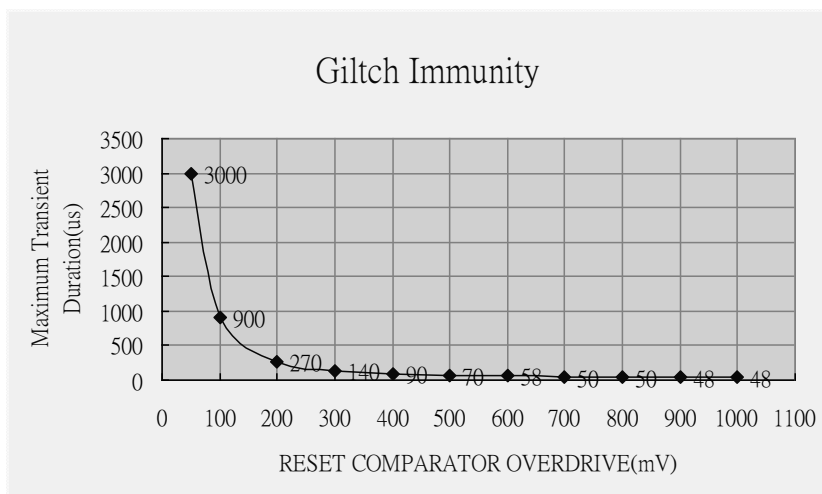
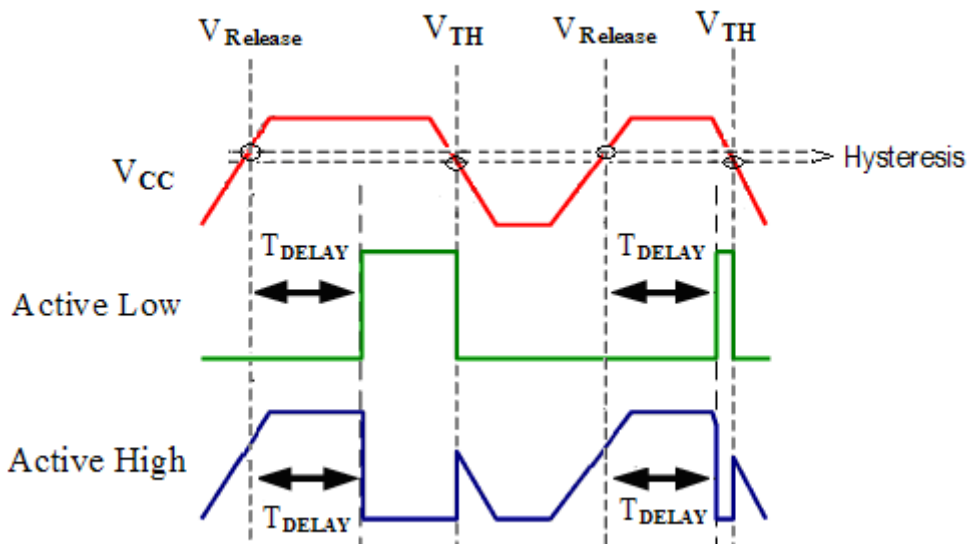

❖ PACKAGE OUTLINES

(1) SOT-23-3L

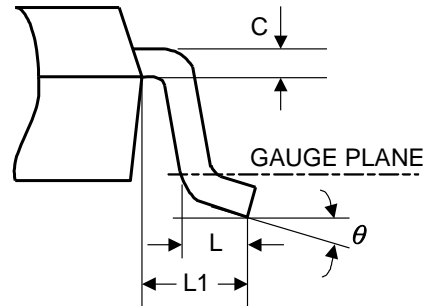
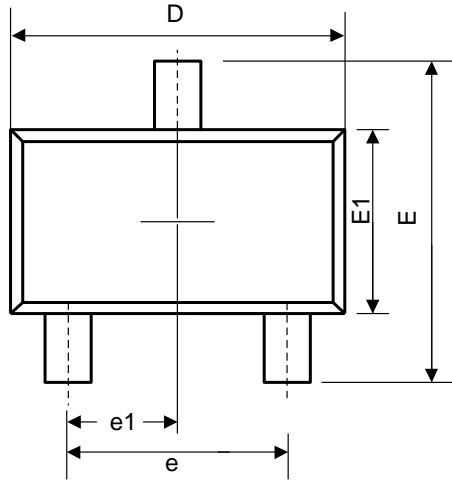

VIEW C

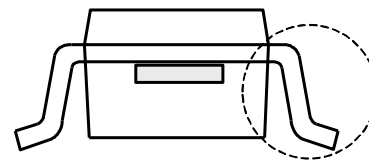
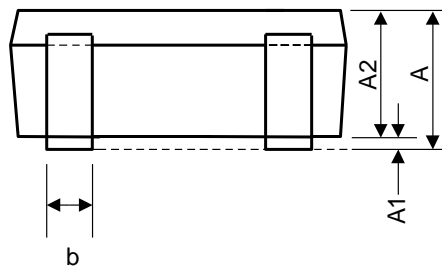

SEE VIEW C

Symbol	Dimensions in Millimeters			Dimensions in Inches		
	Min.	Nom.	Max.	Min.	Nom.	Max.
A	1.05	-	1.45	0.041	-	0.057
A1	0.05	-	0.15	0.002	-	0.006
A2	0.90	1.10	1.30	0.035	0.043	0.051
b	0.30	-	0.50	0.012	-	0.020
C	0.08	-	0.20	0.003	-	0.008
D	2.70	2.90	3.10	0.106	0.114	0.122
E	2.60	2.80	3.00	0.102	0.110	0.118
E1	1.40	1.60	1.80	0.055	0.063	0.071
L	0.30	-	0.60	0.012	-	0.024
L1	0.50	0.60	0.70	0.020	0.024	0.028
e	1.80	1.90	2.00	0.071	0.075	0.079
e1	0.85	1.00	1.15	0.033	0.039	0.045
θ	0°	5°	10°	0°	5°	10°

(2) SC70-3L

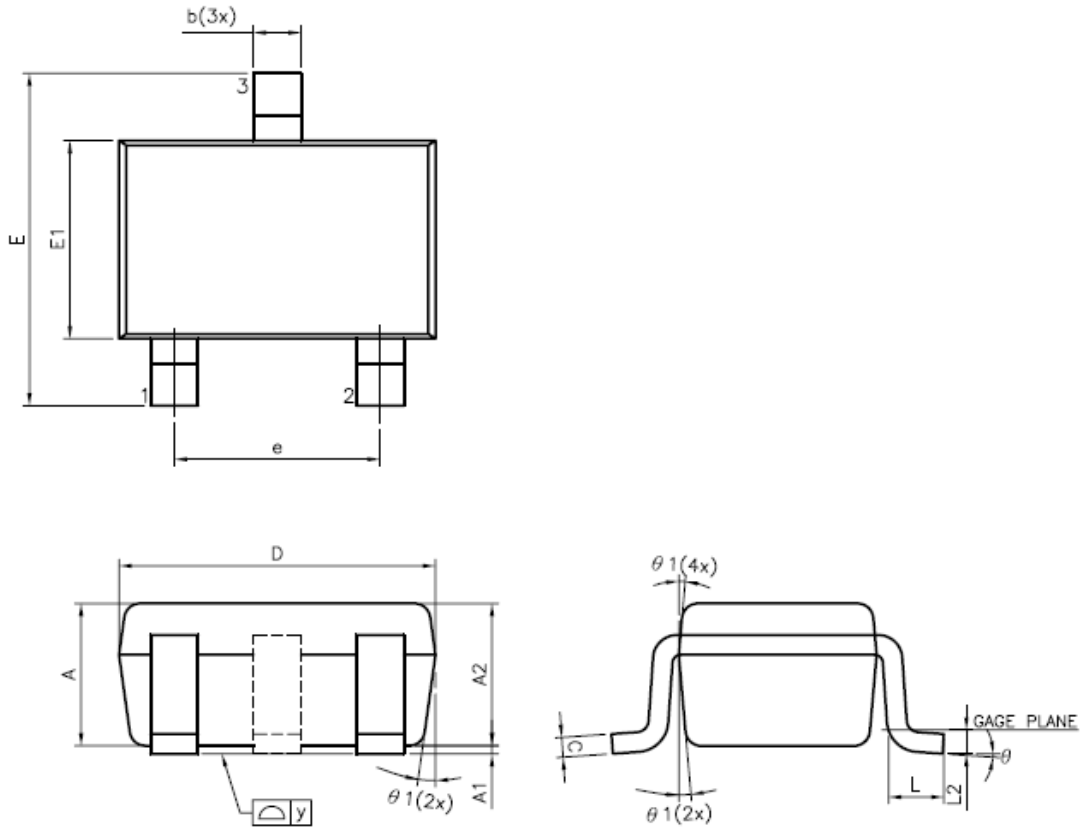

Symbol	Dimensions in Millimeters			Dimensions in Inches		
	Min.	Nom.	Max.	Min.	Nom.	Max.
A	0.80	-	1.10	0.031	-	0.043
A1	0.00	-	0.10	0.000	-	0.004
A2	0.70	0.90	1.00	0.280	0.035	0.039
b	0.25	-	0.40	0.010	-	0.016
C	0.08	-	0.22	0.003	-	0.009
D	1.80	2.00	2.20	0.071	0.079	0.087
E	1.95	2.10	2.25	0.077	0.083	0.089
E1	1.15	1.25	1.35	0.045	0.049	0.053
e	-	1.30	-	-	0.051	-
L	0.26	0.36	0.46	0.010	0.014	0.018
L2	-	0.15	-	-	0.006	-
y	-	-	0.10	-	-	0.004
θ	0°	4°	8°	0°	4°	8°
θ	4°	-	12°	4°	-	12°