

300mA LDO Regulator with Enable

❖ GENERAL DESCRIPTION

The AX6646/A is a 300mA, low quiescent, high PSRR, low noise and low dropout linear regulator. The Device includes pass element, error amplifier, band-gap, current limit and thermal shutdown circuitry. The characteristics of low dropout voltage and less quiescent current make it good for some critical current application, for example, some battery powered devices. The typical quiescent current is approximately 40 μ A. In the shutdown mode, the maximum supply current is less than 1 μ A. The Output voltage is adjustable from 0.8V to 5.5V. Built-in current-limit, Short current protection and thermal-shutdown functions prevent any fault condition from IC damage.

❖ FEATURES

- Input voltage range is up to 6V
- 200mV Dropout at 150mA output current
- Guaranteed 300mA output current
- Low quiescent current 40 μ A (typ.)
- Adjustable Output voltage form 0.8V to 5.5V
- Maximum shutdown current <1 μ A
- Fast transient response
- Current limit and thermal shutdown protection
- Short circuit current fold-back
- Available in the 5-Pin Pb-Free SOT23 Package
- RoHS and Halogen free compliance.

❖ BLOCK DIAGRAM

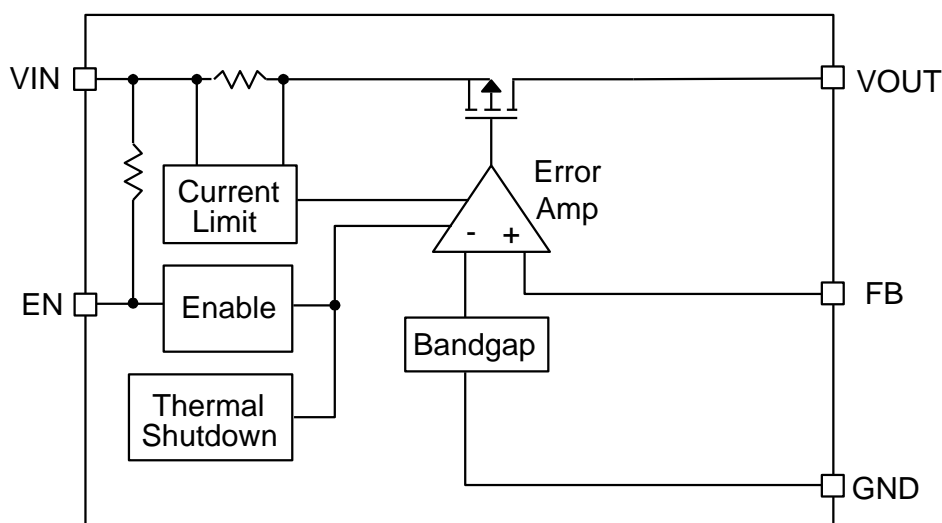

❖ **PIN ASSIGNMENT**

The package of AX6646/A is SOT23-5L; the pin assignment is given by:

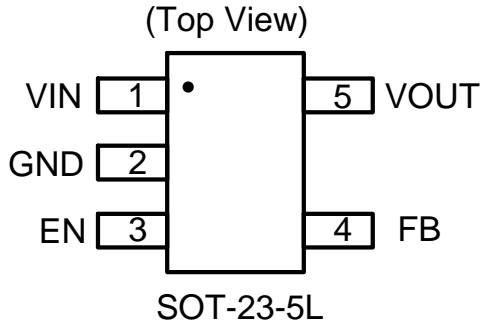

Name	Description
VIN	Input voltage
GND	Ground
EN	Active-Low Shutdown Input. A logic low reduces the supply current to less than 1μA. Connect to V _{IN} or Floating for normal operation.
FB	Feedback Input for Setting the Output Voltage. Connect to an external resistor divider for adjustable output operation.
VOUT	Regulator Output Voltage. Adjustable from 0.8V to +5.5V.

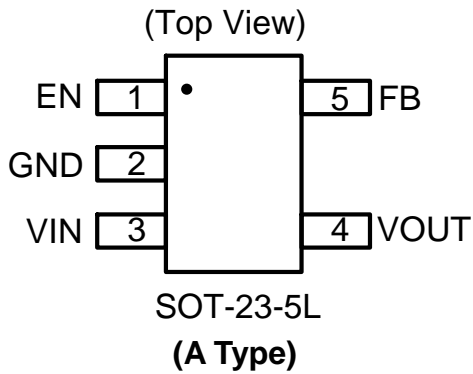

❖ **ORDER/MARKING INFORMATION**

Order Information	
AX6646 X X X Pin Type Package Packing Blank: B : SOT-23-5L Blank: Bulk A: A Type A : Taping	
Top Marking	Top Marking (A Type)
L 8 Y W X → ID code: internal WW: 01~26 (A~Z) 27~52 (a~z) ↓ AX6646 Year: 8=2018 9=2019 B=2020 C=2021 D=2022 Z=2044	L 9 Y W X → ID code: internal WW: 01~26 (A~Z) 27~52 (a~z) ↓ AX6646A Year: 8=2018 9=2019 B=2020 C=2021 D=2022 Z=2044

❖ ABSOLUTE MAXIMUM RATINGS (at T_A=25°C)

Characteristics	Symbol	Rating	Unit
V _{IN} Pin Voltage	V _{IN}	GND - 0.3 to + 6.5	V
Output Voltage	V _{OUT}	GND - 0.3 to V _{IN} + 0.3	V
EN Pin Voltage	V _{EN}	GND - 0.3 to + 6.5	V
FB Pin Voltage	V _{FB}	GND - 0.3 to + 6.5	V
Power Dissipation	PD	400	mW
Storage Temperature Range	T _{ST}	-40 to +150	°C
Operating Junction Temperature	T _J	-40 to +125	°C
Thermal Resistance from Junction to case	θ _{JC}	180	°C/W
Thermal Resistance from Junction to ambient	θ _{JA}	250	°C/W

Note : θ_{JA} is measured with the PCB copper area of approximately 1 in²(Multi-layer).

❖ ELECTRICAL CHARACTERISTICS (V_{IN}=5V, T_A=25°C unless otherwise noted)

Characteristics	Symbol	Conditions	Min	Typ	Max	Units	
Input Voltage	V _{IN}	(Note 1)	2.6	-	6	V	
FB Voltage	V _{FB}	V _{IN} =2.6V to 6V, I _{OUT} =1mA	0.784	0.8	0.816	V	
FB Input Leakage Current	I _{FB}	V _{FB} =1.0V	-100	-	100	nA	
Adjustable Output Voltage Range	V _{OUT}		V _{FB}	-	5.5	V	
Quiescent Current	I _Q	I _{OUT} =0mA, V _{IN} =5V	-	40	60	μA	
Shutdown Current	I _{SD}	V _{IN} =3.6V, V _{EN} =0V	-	-	1	μA	
Dropout Voltage (Note 2)	V _{DROP}	I _{OUT} =300mA, V _{OUT} > 2.7V	-	0.2	0.3	V	
Current Limit (Note 3)	I _{LIMIT}		400	600	-	mA	
Short Circuit Current	I _{short}	V _{OUT} < 0.25*V _{OUT}	-	250	-	mA	
Load Regulation (Note 4)	ΔV _{LOAD}	I _{OUT} =10m~300mA	-	-	0.02	%/mA	
Ripple Rejection	PSRR	C _{IN} =1μF C _{OUT} =1uF I _{OUT} =100mA	F=120Hz	-	65	-	dB
			F=1KHz	-	60	-	
Enable Input Threshold	V _{ENH}	Regulator Enable	2.0	-	-	V	
	V _{ENL}	Regulator Shutdown	-	-	0.4		
Enable Pin Current	I _{ENH}	V _{EN} =V _{IN}	-	0.003	0.1	μA	
	I _{ENL}	V _{EN} =0V, V _{IN} =3.6V	-	0.35	1		
Thermal Shutdown	T _{SD}		-	150	-	°C	
Thermal Shutdown Hysteresis	T _{SH}		-	30	-	°C	

Note 1: Minimum V_{IN} voltage is defined by output adds a dropout voltage.

Note 2: The dropout voltage is defined as (V_{IN}-V_{OUT}), the performance of every AX6646/A part, see “Typical Performance Characteristics”.

Note 3: Current limit is measured at constant junction temperature by using pulsed testing with a low ON time.

Note 4: Regulation is measured at constant junction temperature by using pulsed testing with a low ON time.

❖ APPLICATION CIRCUIT

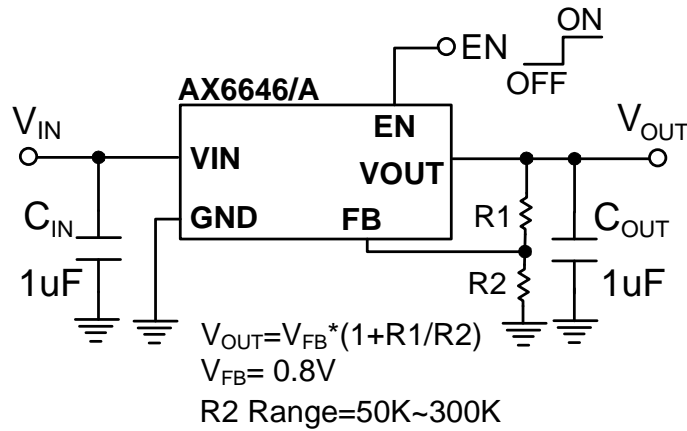

❖ FUNCTION DESCRIPTIONS

A minimum of 1µF capacitor must be connected from V_{OUT} to ground to insure stability. Typically a large storage capacitor is connected from V_{IN} to ground to ensure that the input voltage does not sag below the minimum dropout voltage during the load transient response. This pin must always be dropout voltage higher than V_{OUT} in order for the device to regulate properly.

Enable Function

The AX6646/A features an LDO regulator enable/disable function. To assure the LDO regulator will switch on; the EN turn on control level must be greater than 2.0 volts. The LDO regulator will go into the shutdown mode when the voltage on the EN pin falls below 0.8 volts. For to protecting the system, the AX6646/A have a quick-discharge function. If the enable function is not needed in a specific application, it may be tied to VIN to keep the LDO regulator in a continuously on state.

FB Function

The output is an adjustable version, the FB voltage is 0.8V. The output voltage can be set by outside resistances. The output voltage, V_{OUT}, is then given by the following equation:

$$V_{OUT} = 0.8 (1 + R1/R2)$$

For the reasons of reducing power dissipation and loop stability, R2 is recommending to choose 50K~300KΩ.

❖ APPLICATION INFORMATION

Like any low-dropout regulator, the AX6646/A requires input and output decoupling capacitors. The device is specifically designed for portable applications requiring minimum board space and smallest components. These capacitors must be correctly selected for good performance (see Capacitor Characteristics Section). Please note that linear regulators with a low dropout voltage have high internal loop gains which require care in guarding against oscillation caused by insufficient decoupling capacitance.

Capacitor Selection

Normally, use a 1 μ F capacitor on the input and a 1 μ F capacitor on the output of the AX6646/A. Larger input capacitor values and lower ESR (X5R, X7R) provide better supply-noise rejection and transient response. A higher- value output capacitor (4.7 μ F) may be necessary if large, fast transients are anticipated and the device is located several inches from the power source.

Input-Output (Dropout) Voltage

A regulator's minimum input-to-output voltage differential (dropout voltage) determines the lowest usable supply voltage. In battery-powered systems, this determines the useful end-of-life battery voltage. Because the device uses a PMOS, its dropout voltage is a function of drain-to source on-resistance, $R_{DS(ON)}$, multiplied by the load current:

$$V_{DROPOUT} = V_{IN} - V_{OUT} = R_{DS(ON)} \times I_{OUT}$$

Current Limit and Short-Circuit Protection

The AX6646/A uses a current sense-resistor to monitor the output current. A portion of the PMOS output transistor's current is mirrored to a resistor such that the voltage across this resistor is proportional to the output current. Once the output current exceeds limit threshold, AX6646/A would be protected with a limited output current. Further more, when the output is short to ground, the output current would be folded-back to a less limit.

Thermal Considerations

The AX6646/A series can deliver a current of up to 300mA over the full operating junction temperature range. However, the maximum output current must be dated at higher ambient temperature to ensure the junction temperature does not exceed 125°C. With all possible conditions, the junction temperature must be within the range specified under operating conditions. Power dissipation can be calculated based on the output current and the voltage drop across regulator.

$$P_D = (V_{IN} - V_{OUT}) I_{OUT}$$

The final operating junction temperature for any set of conditions can be estimated by the following thermal equation:

$$P_{D(MAX)} = (T_{J(MAX)} - T_A) / \theta_{JA}$$

Where $T_{J(MAX)}$ is the maximum junction temperature of the die (125°C) and T_A is the maximum ambient temperature. The junction to ambient thermal resistance (θ_{JA}) for SOT-23-5L package at recommended minimum footprint is 250°C/W.

PCB Layout

An input capacitance of $\cong 1\mu\text{F}$ is required between the AX6646/A input pin and ground (the amount of the capacitance may be increased without limit), this capacitor must be located a distance of not more than 1cm from the input and return to a clean analog ground. Input capacitor can filter out the input voltage spike caused by the surge current due to the inductive effect of the package pin and the printed circuit board's routing wire. Otherwise, the actual voltage at the IN pin may exceed the absolute maximum rating. The output capacitor also must be located a distance of not more than 1cm from output to a clean analog ground. Because it can filter out the output spike caused by the surge current due to the inductive effect of the package pin and the printed circuit board's routing wire.

❖ TYPICAL CHARACTERISTICS

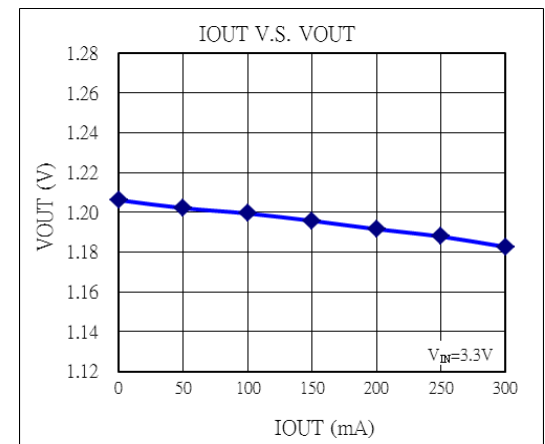
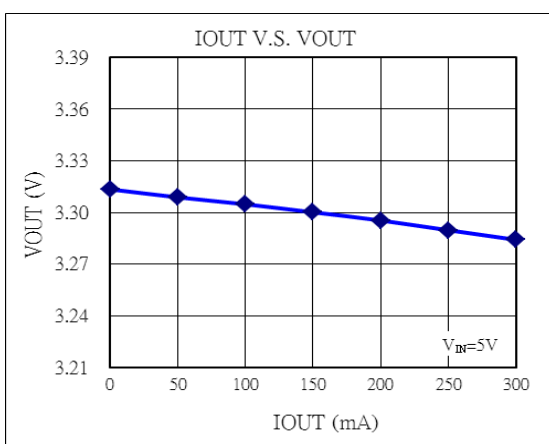
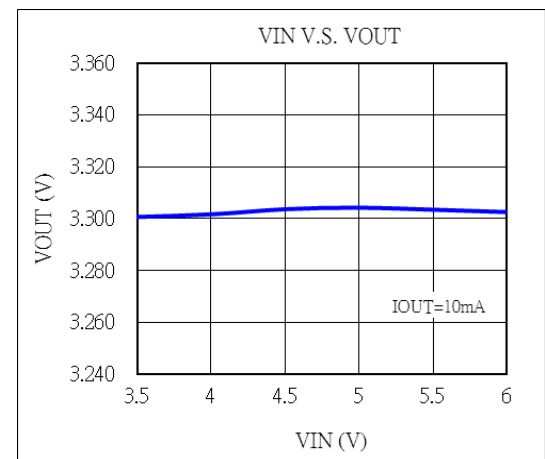
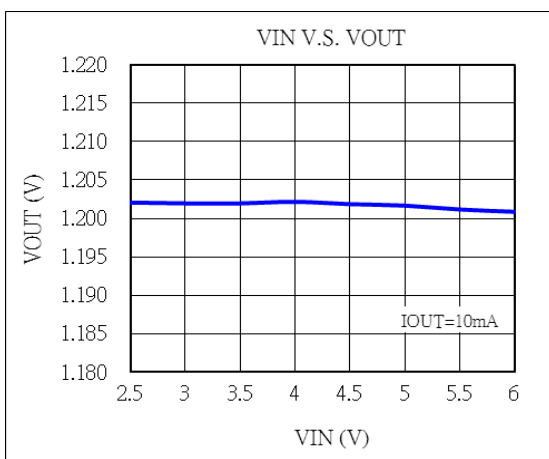
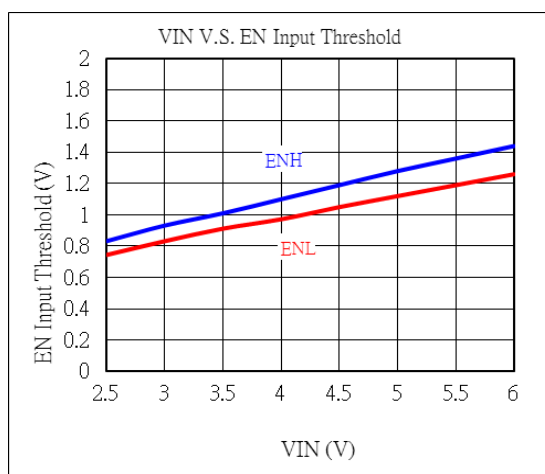
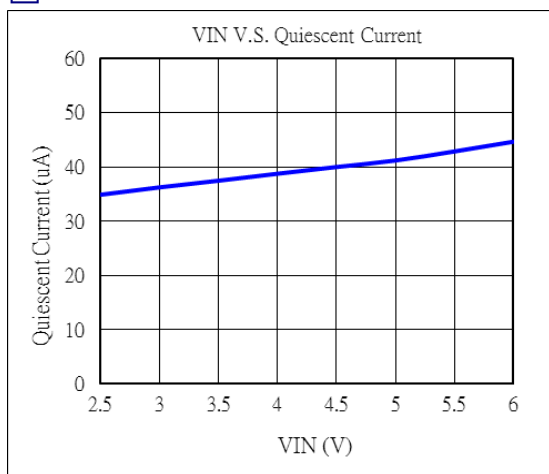

❖ **TYPICAL CHARACTERISTICS (CONTINUOUS)**

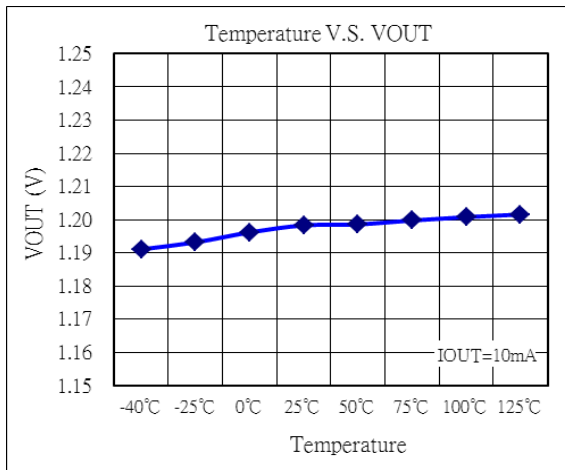
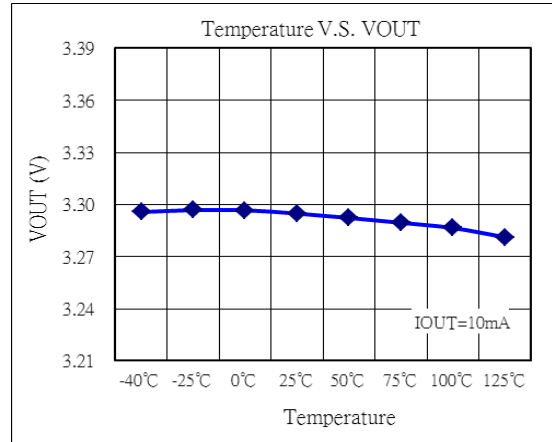
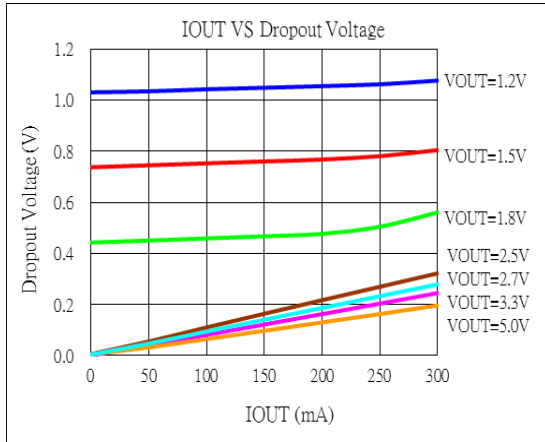

❖ TYPICAL CHARACTERISTICS (CONTINUOUS)

Load transient response

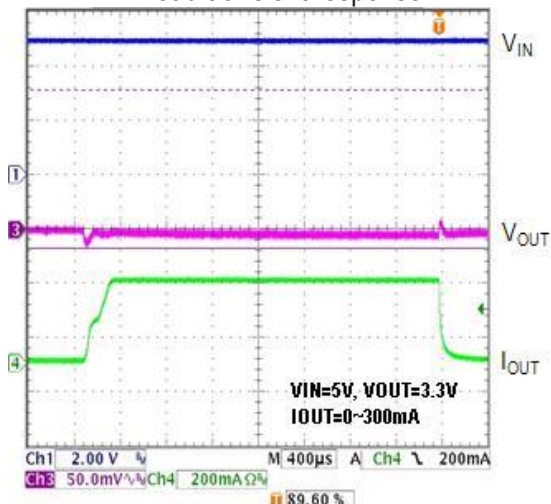

Load transient response

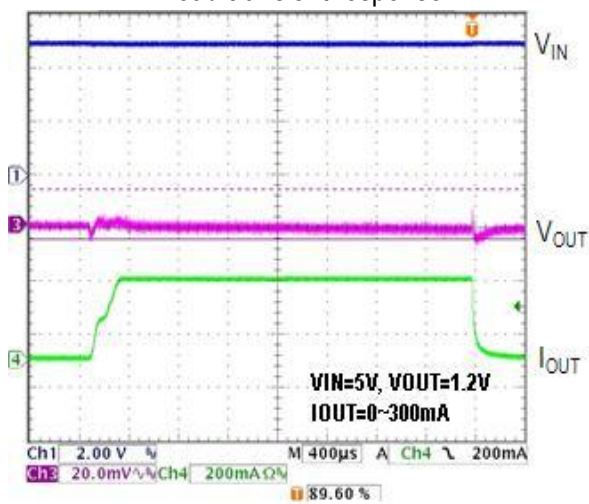

Power ON

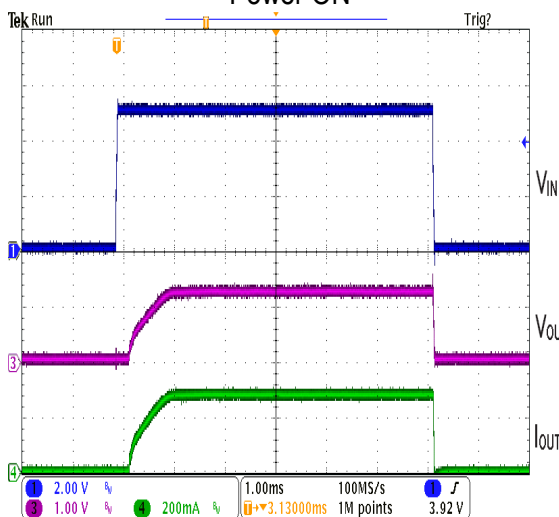

Power ON

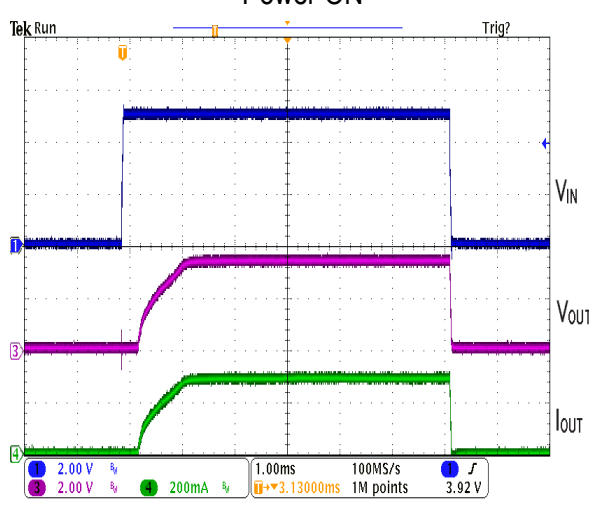

EN ON

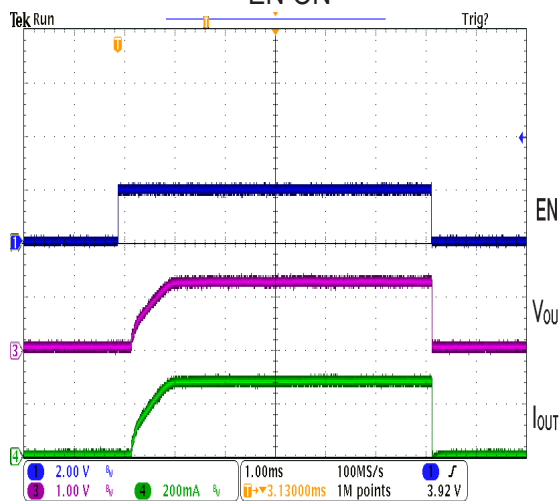

EN ON

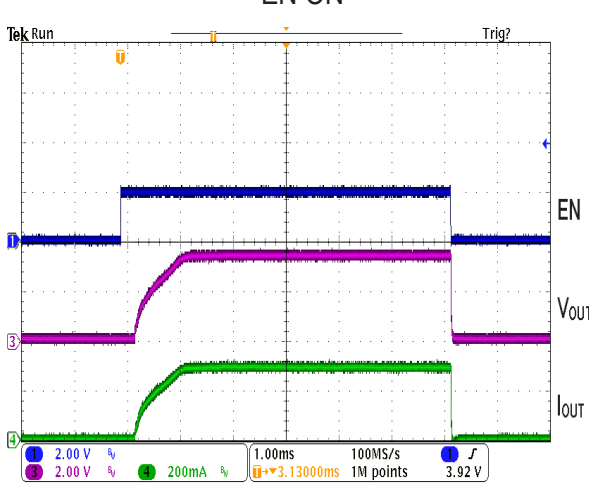

❖ PACKAGE OUTLINES

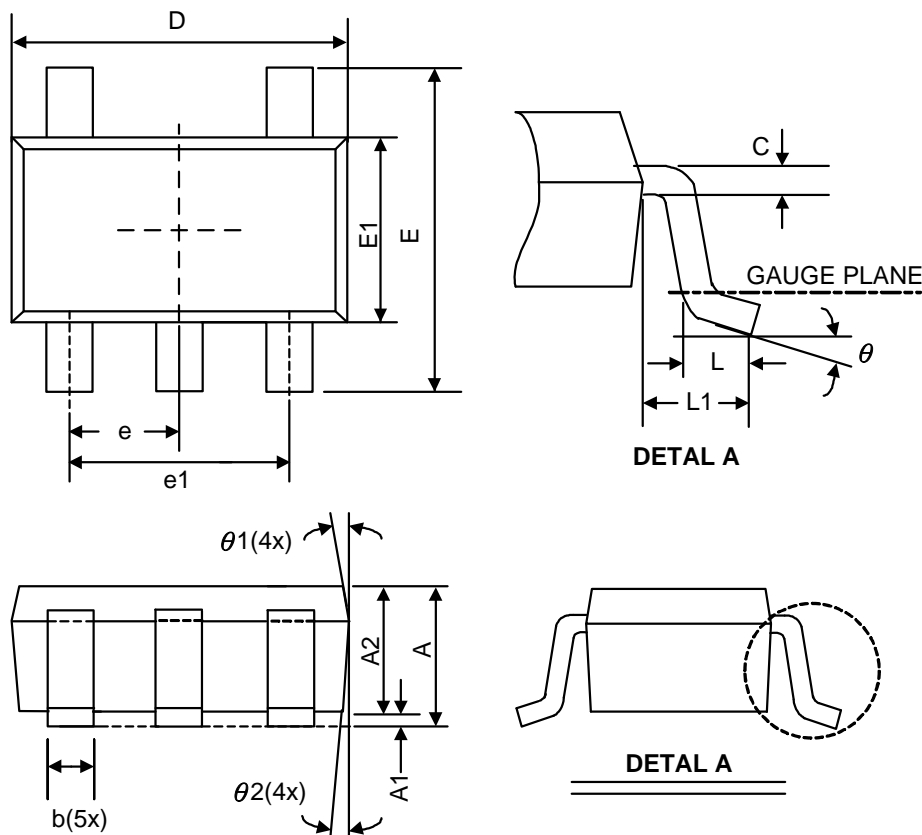

Symbol	Dimensions in Millimeters			Dimensions in Inches		
	Min.	Nom.	Max.	Min.	Nom.	Max.
A	-	-	1.45	-	-	0.057
A1	0	0.08	0.15	0	0.003	0.006
A2	0.9	1.1	1.3	0.035	0.043	0.051
b	0.3	0.4	0.5	0.012	0.016	0.02
C	0.08	0.15	0.22	0.003	0.006	0.009
D	2.7	2.9	3.1	0.106	0.114	0.122
E1	1.4	1.6	1.8	0.055	0.063	0.071
E	2.6	2.8	3	0.102	0.11	0.118
L	0.3	0.45	0.6	0.012	0.018	0.024
L1	0.5	0.6	0.7	0.02	0.024	0.028
e1	1.9 BSC			0.075 BSC		
e	0.95 BSC			0.037 BSC		
θ	0°	4°	8°	0°	4°	8°
$\theta 1$	5°	10°	15°	5°	10°	15°
$\theta 2$	5°	10°	15°	5°	10°	15°

JEDEC outline: MO-178 AA

❖ Carrier tape dimension

SOT-23-5L

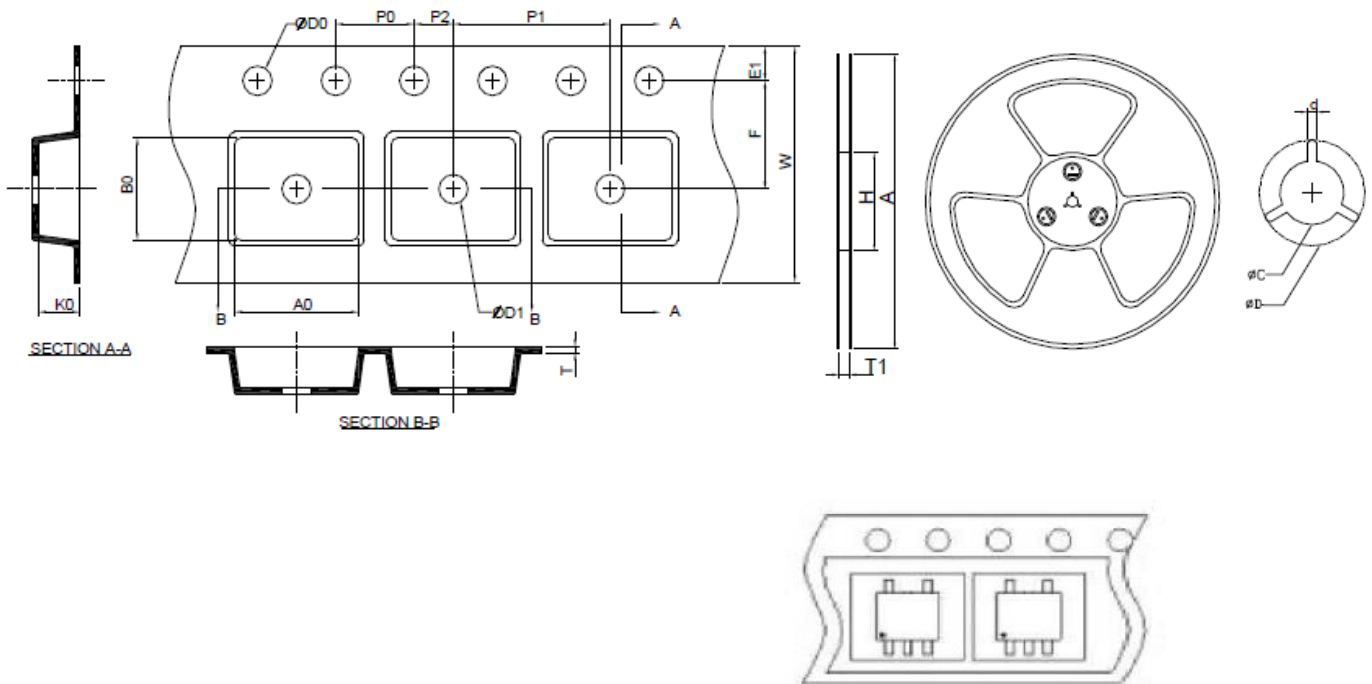

A	H	T1	C	d	D	W	E1	F
178.0±2.00	50 MIN.	8.4+2.00 -0.00	13.0+0.50 -0.20	1.5 MIN.	20.2 MIN.	8.0±0.30	1.75±0.10	3.5±0.05
P0	P1	P2	D0	D1	T	A0	B0	K0
4.0±0.10	4.0±0.10	2.0±0.05	1.5+0.10 -0.00	1.0 MIN.	0.6+0.00 -0.40	3.20±0.20	3.10±0.20	1.50±0.20

(mm)