

Wide Input Range CC/CV Step Down

Controller

❖ GENERAL DESCRIPTION

The AX3071 is a step down PWM controller with a driving dual output current to 4.8A (2.4A+2.4A). It is designed to allow for operating a wide supply voltage range from 9V to 40V. The external shutdown function can be controlled by logic level to pull COMP/EN pin down, and then comes into standby mode. The external compensation makes feedback control have good line and load regulation with flexible external design.

The AX3071 operates in the CC(Constant output Current) mode or CV(Constant output Voltage) mode, and the OCP current value is set by current sensing resistors.

The AX3071 is suitable for the DC/DC switching power applications when requested the current limit function. The devices are available in MSOP-10L packages and require very few external devices for operation.

❖ FEATURES

- V_{IN} Operate with 9V ~ 40V Supply Voltage
- V_{OUT} Accuracy ($V_{REF} = 1.0V$) $\pm 2.0\%$
- Dual-Channeling CC/CV Mode Control
- External Current Limit Setting for 2 channel
- Over Temperature Protection
- Internal Soft Start ~ 3ms
- Fixed Frequency 120KHz
- UVLO Protection (min=7V, typ=7.5V, max=8V)
- Duty Cycle Range (0~90%)
- Single Pin to External Compensation and Shutdown Control
- C_{OUT} MLCC support.
- Built in Adjustable Line-Compensation
- MSOP-10L Package
- RoHS and Halogen free compliance

❖ APPLICATION

- Car Charger
- High-Brightness Lighting
- Portable Charger Devices
- General-Purpose DC/DC Controller with Current Limit

❖ BLOCK DIAGRAM

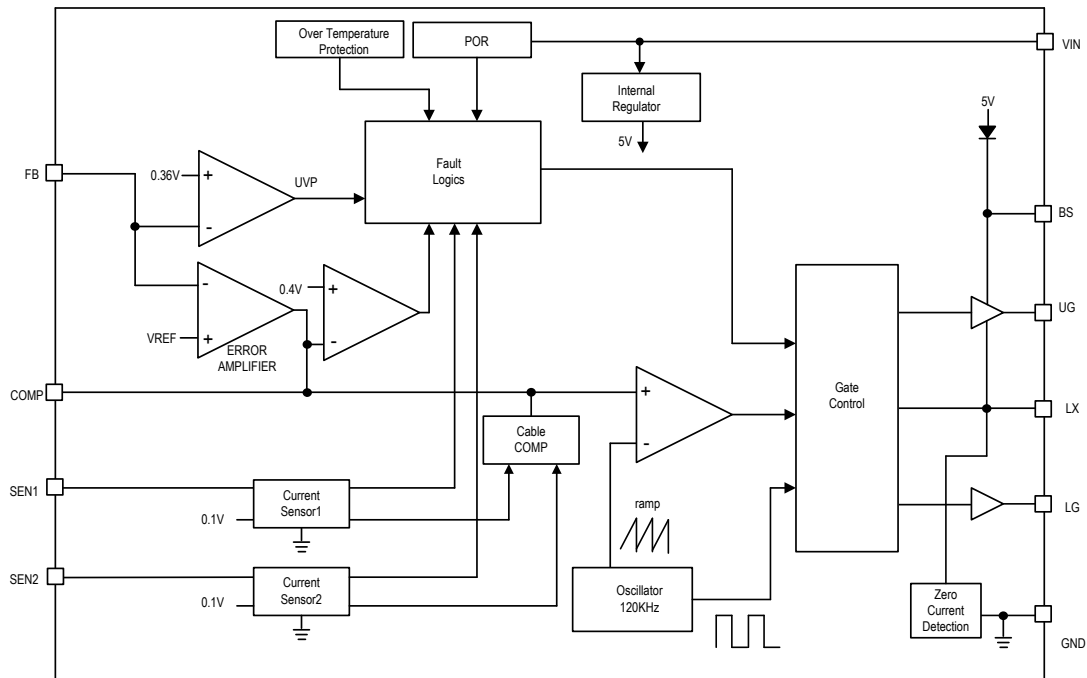

❖ PIN ASSIGNMENT

The package of AX3071 is MSOP-10L the pin assignment is given by:

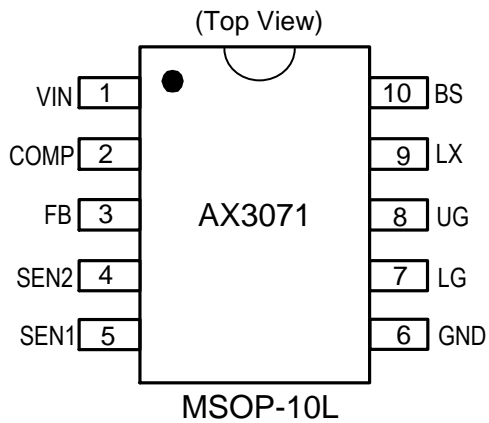

Name	Description
VIN	Power Supply Input. Bypass this pin with a 1uF ceramic capacitor to GND, placed as close to the IC as possible.
COMP	Error Amplifier Output. This is the output of the error amplifier (EA) and the non-inverting input of the PWM comparator. Use this pin in combination with the FB pin to compensate the voltage control feedback loop of the converter. Pulling COMP to a level below 0.4V nominal disables the controller, causes the oscillator to stop, and makes the UGATE and LGATE outputs held low.
FB	Feedback Pin. The voltage at this pin is regulated to 1.0V. Connect to the resistor divider between output and GND to set the output voltage.
SEN2	The Current Sense Input2 (+) Pin. When the SEN2 is larger than the current sense voltage, OCP function will enable.
SEN1	The Current Sense Input1 (+) Pin. When the SEN1 is larger than the current sense voltage, OCP function will enable.
GND	Ground. Connect this pin to a large PCB copper area for best heat dissipation, Return FB, and COMP to this GND and connect this GND to power GND at a single point for best noise immunity.
LG	Output to Low-side Gate Driver.
UG	Output to High-side Gate Driver.
LX	Power Switching Output to External Inductor.
BS	Bootstrap Pin. This provides power to the internal higher MOSFET gate driver. Connect a 100nF capacitor from BS pin to LX pin.

❖ **ORDER/MARKING INFORMATION**

Order Information	Top Marking
<p>AX3071 X X</p> <p>Package Type: U: MSOP-10L</p> <p>Packing: Blank : Tube, A : Taping</p>	<p>Logo ← AX 3 0 7 1 → Part number</p> <p>Y Y W W X → ID code: internal</p> <p>WW: 01~52</p> <p>Year: 18=2018, 19=2019, 20=2020, 21=2021, 22=2022, ..., 45=2045</p>

❖ ABSOLUTE MAXIMUM RATINGS (at $T_A = 25^\circ\text{C}$)

Characteristics	Symbol	Rating	Unit
Supply Input Voltage	V_{IN}	-0.3 to +43	V
BS to LX		-0.3 to +7	V
LX to GND		-1 to $V_{IN}+1$	V
BS, UG to GND		$V_{SW}-0.3$ to $V_{SW}+7$	V
FB, COMP, LG, SEN1, SEN2 to GND		0.3 to +7	V
ESD HBM (Human Body Mode)		$\pm 2\text{K}$	V
ESD MM (Machine Mode)		± 200	V
Power Dissipation, PD @ $T_A=25^\circ\text{C}$	P_D	$(T_J - T_A) / \theta_{JA}$	W
Thermal Resistance from Junction to case	θ_{JC}	43	$^\circ\text{C/W}$
Thermal Resistance from Junction to ambient	θ_{JA}	135	$^\circ\text{C/W}$

❖ RECOMMENDED OPERATION CONDITIONS

Characteristics	Symbol	Rating	Unit
Storage Temperature Range	T_{ST}	-65 to +150	$^\circ\text{C}$
Junction Temperature	T_J	-40 to +125	$^\circ\text{C}$
Operating Temperature	T_{OP}	-40 to +85	$^\circ\text{C}$
Lead Temperature Range(Soldering 10sec)		260	$^\circ\text{C}$

❖ ELECTRICAL CHARACTERISTICS
 $V_{CC}=12V$, $T_A=25^{\circ}C$ (unless otherwise specified.) Mosfet use AMS4004*2.

Characteristics	Symbol	Test Conditions	Min	Typ	Max	Units
Supply Voltage Range V_{IN}	V_{CC}		9	-	40	V
Supply Input Current	I_{CCQ}	COMP/EN=GND	-	2	-	mA
	I_{CC}	12Vin Vout=5V, No load	-	7.5	-	mA
	I_{CC}	30Vin Vout=5V, No load	-	15	20	mA
Power-On-Reset						
VCC POR Threshold	V_{CCRTH}	V_{CC} Rising.	7	7.5	8	V
	V_{CCFTH}	V_{CC} Falling.	6	6.5	7	
Oscillator						
Normal PWM Frequency	F_{OSC}	$I_{OUT}=200mA$	96	120	144	KHz
Minimum On-Time	T_{ON-MIN}		-	200	-	ns
Duty Cycle Range	Duty		0	-	90	%
Reference						
Reference Voltage	V_{REF}		-	1.0	-	V
Reference Voltage Tolerance			-2	-	+2	%
Line compensation Current	I_{FB}	V_{SEN1} or $V_{SEN2} = 100mV$	-	5	-	μA
PWM Error Amplifier						
COMP Shutdown Threshold Voltage			-	0.4	-	V
COMP Source Current		$V_{COMP}=V_{COMP_H} - 1V$	-	132	-	μA
COMP Sink Current		$V_{COMP}=1V$	-	126	-	μA
Current Sense Amplifier						
Difference Voltage between SEN- and SEN+	ΔV_{SEN}		95	100	105	mV
Pre-Driver (Ensured by design)						
UG Driver	source		-	7	-	Ω
	sink		-	1.5	-	Ω
LG Driver	source		-	10	-	Ω
	sink		-	1.2	-	Ω
Dead Time		UG low to LG high	-	40	-	nS
		LG low to UG high	-	100	-	nS

❖ ELECTRICAL CHARACTERISTICS

$V_{CC}=12V, T_A=25^{\circ}C$ (unless otherwise specified.) Mosfet use AMS4004*2.

Characteristics	Symbol	Test Conditions	Min	Typ	Max	Units
Protection						
Over Temperature Shutdown			-	160	-	$^{\circ}C$
Over Temperature Hysteresis			-	40	-	$^{\circ}C$
Soft Start						
Soft Start Time	T_{SS}		-	3	-	ms
Recycle Time			-	0.5	-	s
Output Short Circuit Protect Section						
Short Circuit Fold Back Voltage	V_{SCP}		-	0.4	-	V

Note 1: Stresses listed as the above "Absolute Maximum Ratings" may cause permanent damage to the device.

These are for stress ratings. Functional operation of the device at these or any other conditions beyond those indicated in the operational sections of the specifications is not implied. Exposure to absolute maximum rating conditions for extended periods may remain possibility to affect device reliability.

Note 2: Devices are ESD sensitive. Handling precaution recommended.

Note 3: θ_{JA} is measured in the natural convection at $T_A = 25^{\circ}C$ on a high effective thermal conductivity test board of JEDEC 51-7 thermal measurement standard.

❖ APPLICATION CIRCUIT

$V_{IN}=10V\sim 40V$

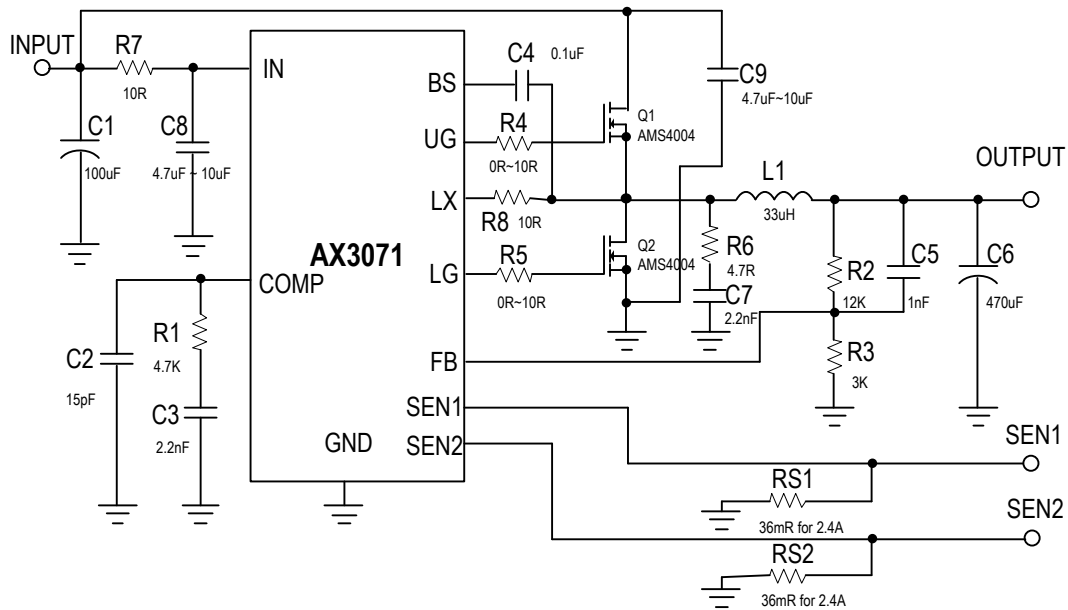

Note: If output only 1 port, the other Sense pin need connect with GND.

❖ QC2.0 APPLICATION CIRCUIT

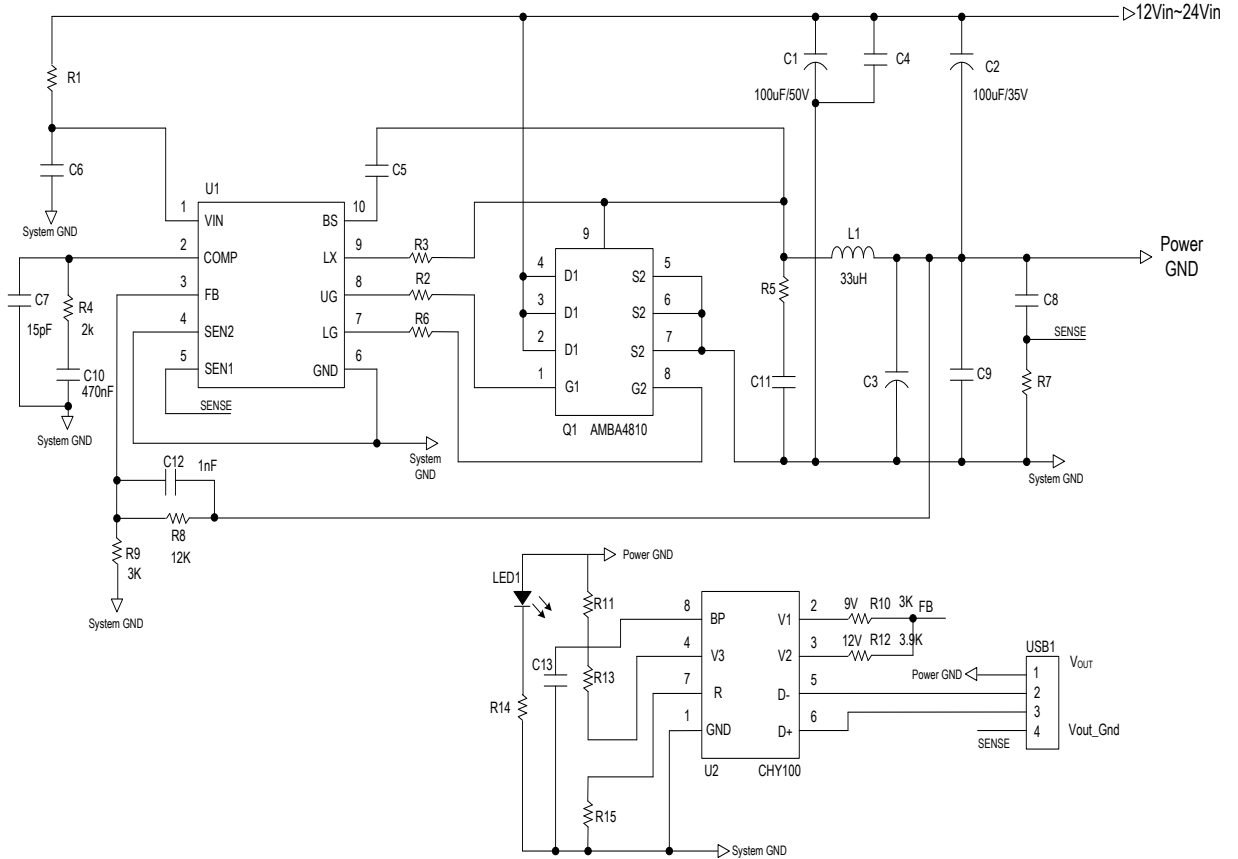

❖ MLCC OUTPUT CAPACITOR APPLICATION

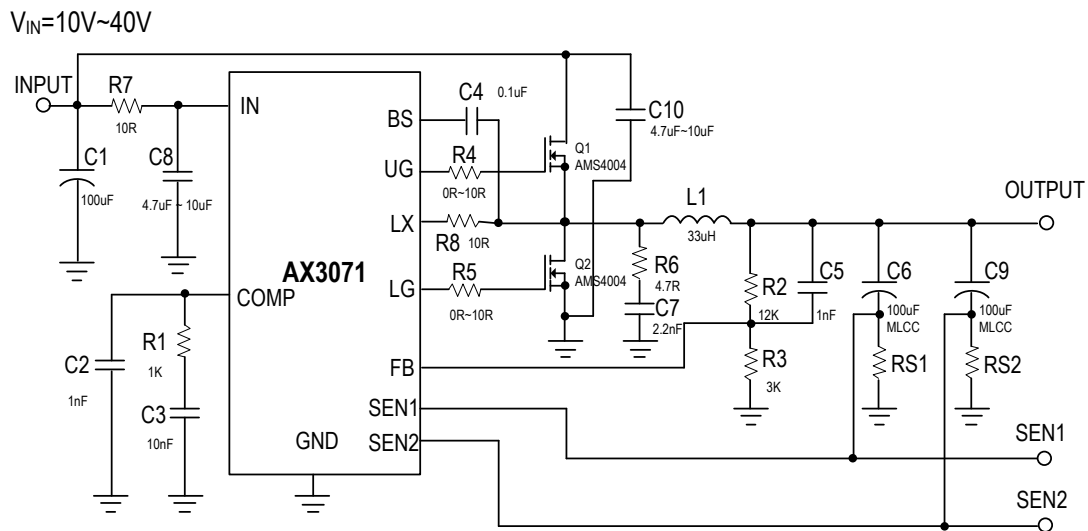

❖ **MOSFET SUGGESTION**

AMS4004*2 for 4.8A → 2.4A+2.4A or 4.8A

BVDSS	RDSON	ID
40V	12mΩ	8.5A

SOP8 Pin configuration

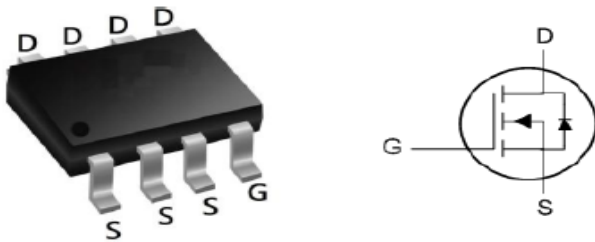

AMBA4810 for 4.8A~6A → 2.4A+2.4A or 2A+2A+2A or 6A

BVDSS	RDSON	ID
40V	17mΩ	39A
40V	8.5mΩ	54A

PRPAK5X6 Pin configuration

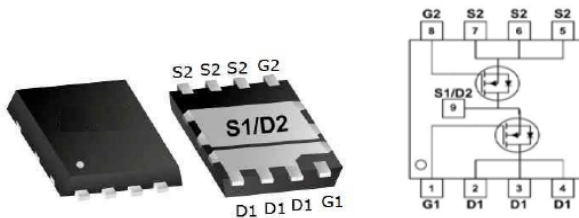

AMS4006*2 for 6A~8A → 2A+2A+2A or 2A+2A+2A+2A or 8A

BVDSS	RDSON	ID
40V	7.5 mΩ	10.5A

SOP8 Pin configuration

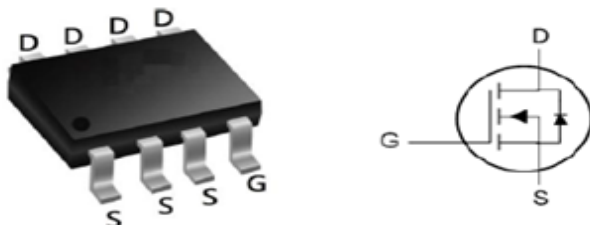

❖ FUNCTION DESCRIPTIONS

CC/CV Mode Control

The AX3071 provides CC/CV function. The Constant output Current control Mode and Constant output Voltage control Mode.

Over Current Protection

The AX3071 provides over current protection. A drop voltage on the current sensing resistor is over the OCP value, the OCP function will shut down the controller.

Soft Start

The AX3071 has internal soft start function to control rise rate of the output voltage and limits the large inrush current at start up. The typical soft start interval is about 3mS.

Power on Reset

A power-on reset circuit monitors the input voltage. When the input voltage exceeds 7.5V, the converter will start operation. Once input voltage falls below 6.5V, the controller will shut down.

Over Temperature Protection

The AX3071 provides over temperature protection. The OTP will shut down the converter when junction temperature exceeds 160°C. Once the junction temperature cools down by approximately 40°C, the converter will resume normal operation.

Current Limit Protection

The Current limit is set by outside resistance (R_{SENSE}), When the SEN1 or SEN2 voltage larger than 100mV, the current limit is happened that driver can be turned off. The current limit set according to the following equation:

$$\text{Current Limit (A)} = \frac{100\text{mV}}{R_{SENSE}}$$

Output Short-Circuit Protection

The AX3071 provides output short-circuit protection function. When V_{OUT} is short

($V_{FB} < 0.4V$), the auto restart function can be started that restart the regulator cycle by cycle. The cycle time is set by internal counter.

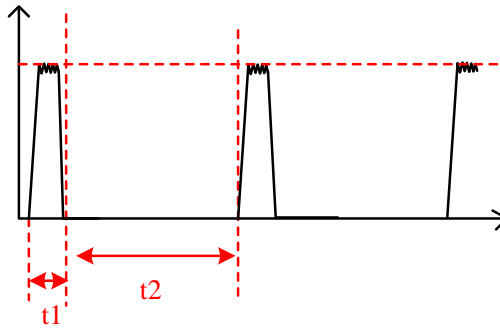

$$t1 = 50m(Sec.)$$

$$t2 = 500m(Sec.)$$

❖ **APPLICATION INFORMATION**

Output Voltage Setting

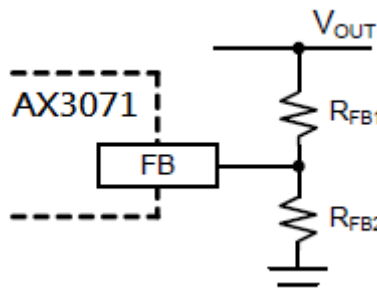

Figure1 Output Voltage Setting

Figure 1 shows the connections for setting the output voltage. Select the proper ratio of the two feedback resistors R_{FB1} and R_{FB2} based on the output voltage. Typically, use $R_{FB2} \approx 1k\Omega$ and determine R_{FB1} from the following equation:

$$R_{FB1} = R_{FB2} \left(\frac{V_{OUT}}{V_{FB}} - 1 \right)$$

Output Cable Resistance Compensation

To compensate for resistive voltage drop across the charger's output cable, the AX3071 integrates a simple, user-programmable cable voltage drop compensation using the impedance at the FB pin. Use the curve in Figure 2 to choose the proper feedback resistance values for cable compensation. R_{FB1} is the high side resistor of voltage divider. The V_{SEN1} or V_{SEN2} take the big one.

$$V_{OUT} = \left[\left(1 + \frac{R_{FB1}}{R_{FB2}} \right) \times V_{FB} \right] + \left[R_{FB1} \times \left(\frac{V_{SEN}}{16.6K} - 1\mu A \right) \right]$$

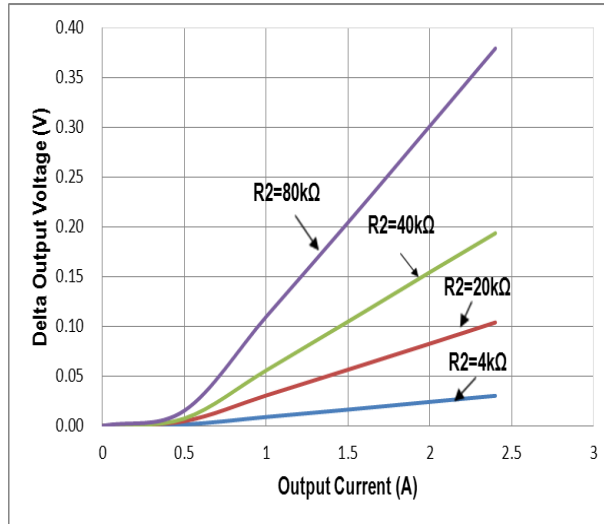

Figure2 12Vin to 5Vout Cable Compensation (RSEN=33mΩ)

Inductor Selection

The inductor maintains a continuous current to the output load. This inductor current has a ripple that is dependent on the inductance value:

Higher inductance reduces the peak-to-peak ripple current. The tradeoff for high inductance value is the increase in inductor core size and series resistance, and the reduction in current handling capability. In general, select an inductance value L based on ripple current requirement:

$$L = \frac{V_{OUT} \times (V_{IN} - V_{OUT})}{V_{IN} f_{LX} I_{OUTMAX} K_{RIPPLE}}$$

where V_{IN} is the input voltage, V_{OUT} is the output voltage, f_{LX} is the switching frequency, I_{OUTMAX} is the maximum output current, and K_{RIPPLE} is the ripple factor. Typically, choose $K_{RIPPLE} = 30\%$ to correspond to the peak-to-peak ripple current being 30% of the maximum output current.

With this inductor value, the peak inductor current is $I_{OUT} \times (1 + K_{RIPPLE}/2)$. Make sure that this peak inductor current is less than the controller's current limit. Finally, select the inductor core size so that it does not saturate at the peak inductor current.

Input Capacitor

The input capacitor needs to be carefully selected to maintain sufficiently low ripple at the supply input of the converter. A low ESR capacitor is highly recommended. Since large current flows in and out of this capacitor during switching, its ESR also affects efficiency.

The input capacitance needs to be higher than 100μF. The best choice is the ceramic type, however, low ESR tantalum or electrolytic types may also be used provided that the RMS ripple current rating is higher than 50% of the output current. The input capacitor should be placed close to the VIN and GND pins of the IC, with the shortest traces possible. In the case of tantalum or electrolytic types, they can be further away if a small parallel 1μF ceramic capacitor is placed right next to the IC. Especially C8 capacitor should be placed as close as possible to the VIN pin.

Output Capacitor

The output capacitor also needs to have low ESR to keep low output voltage ripple. The output ripple voltage is:

$$V_{\text{RIPPLE}} = I_{\text{OUTMAX}} K_{\text{RIPPLE}} R_{\text{ESR}} + \frac{V_{\text{IN}}}{28 \times f_{\text{LX}}^2 LC_{\text{OUT}}}$$

where I_{OUTMAX} is the maximum output current, K_{RIPPLE} is the ripple factor, R_{ESR} is the ESR of the output capacitor, f_{LX} is the switching frequency, L is the inductor value, and C_{OUT} is the output capacitance. In the case of ceramic output capacitors, R_{ESR} is very small and does not contribute to the ripple. Therefore, a lower capacitance value can be used for ceramic type. In the case of tantalum or electrolytic capacitors, the ripple is dominated by R_{ESR} multiplied by the ripple current. In that case, the output capacitor is chosen to have sufficiently low ESR.

For ceramic output capacitor, typically choose a capacitance of about 470μF. For tantalum or electrolytic capacitors, choose a capacitor with less than 50mΩ ESR.

PCB Layout Recommendations

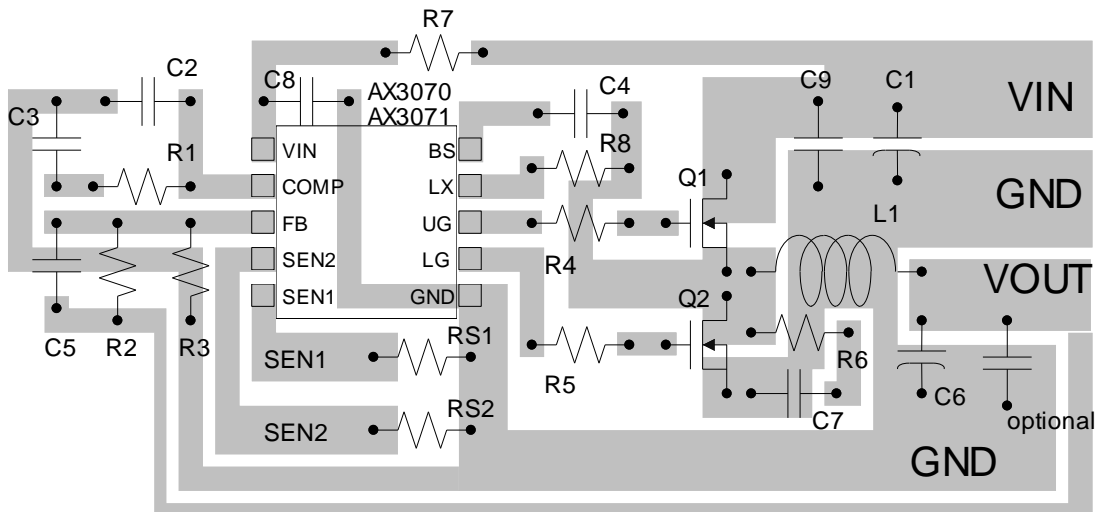

1. PCB trace defined as LX node, which connects to source of switching MOSFET, drain of rectifying MOSFET and high-voltage side of the inductor, should be as short and wide as possible.
2. All sensitive analog traces such as SEN1, SEN2, COMP and FB should place away from high-voltage switching nodes such as LX, UG or LG nodes to avoid coupling.
3. C8 input bypass capacitor should be placed to the VIN pin as close as possible.
4. Connections from the drivers to the respective gate of the high-side or the low-side MOSFET should be as short as possible to reduce stray inductance. Use a 0.65 mm (25 mils) or wider trace.
5. Gather the ground terminals of the V_{IN} capacitor(s), V_{OUT} capacitor(s), and the source of the low-side MOSFETs as close as possible. Signal ground and power ground should be connected strongly together near the device.

❖ TYPICAL CHARACTERISTICS

100mA Light Load Power On/Off
12V_{IN} to 5V_{OUT}

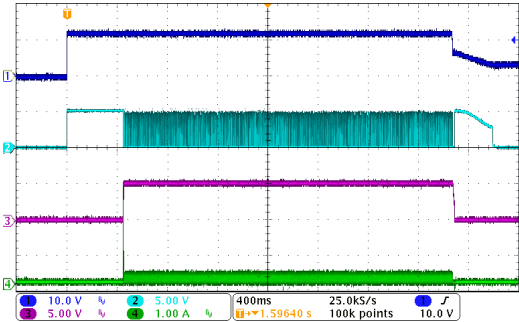

5A Full Load Power On/Off
12V_{IN} to 5V_{OUT}

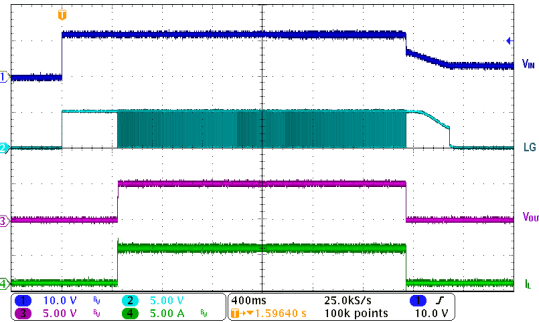

100mA~5A Load Transient Test
12V_{IN} to 5V_{OUT}

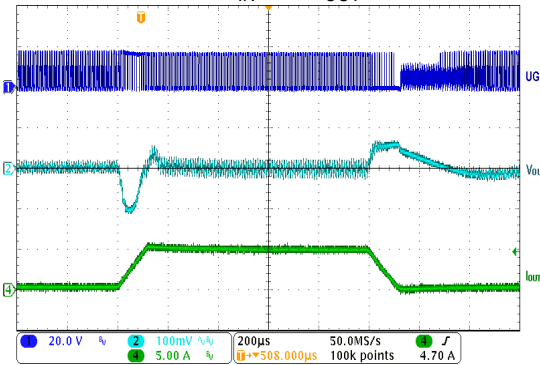

12V_{IN} ~24V_{IN} Line Transient Test
5V_{OUT} 100mA Load

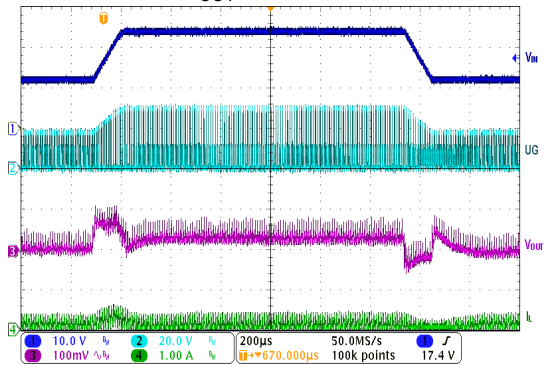

Over Current Protection
12V_{IN} to 5V_{OUT}

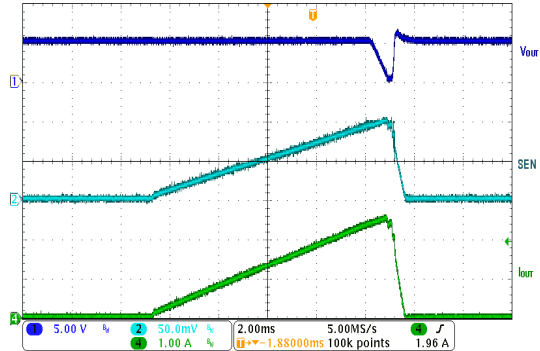

Output Short Circuit Protection
12V_{IN} to 5V_{OUT}

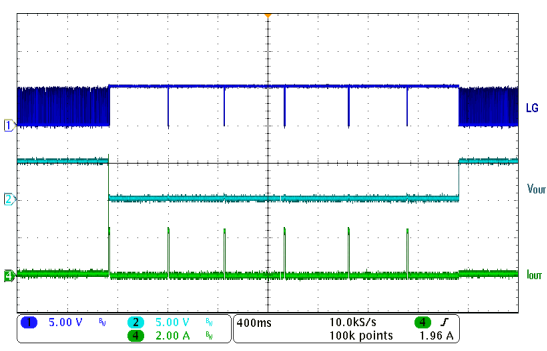

❖ TYPICAL CHARACTERISTICS (CONTINUOUS)

CC and CV Mode I-V Curve
12V_{IN} to 5V_{OUT}

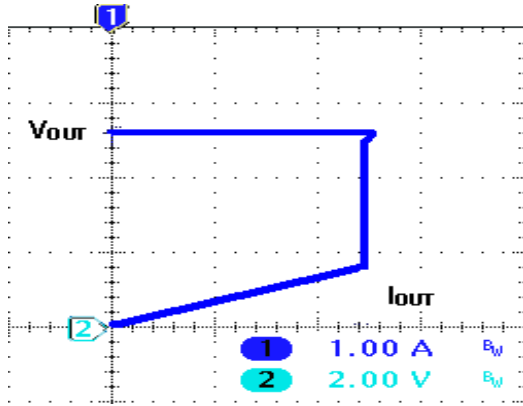

COMP Pull Low to Shutdown Output
12V_{IN} to 5V_{OUT}, 100mA load

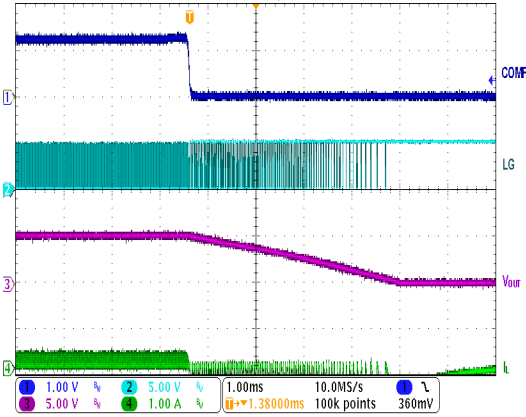

I_{OUT} vs Efficiency, V_{OUT}=5V

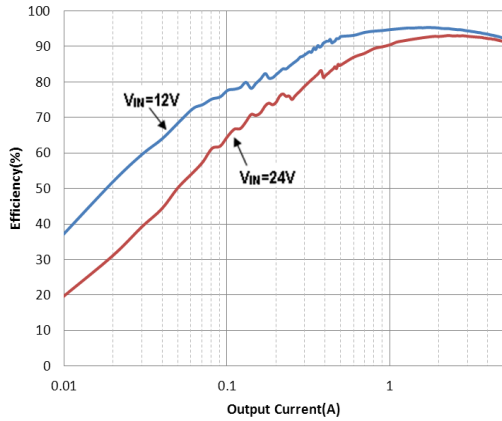

I_{OUT} vs V_{OUT}

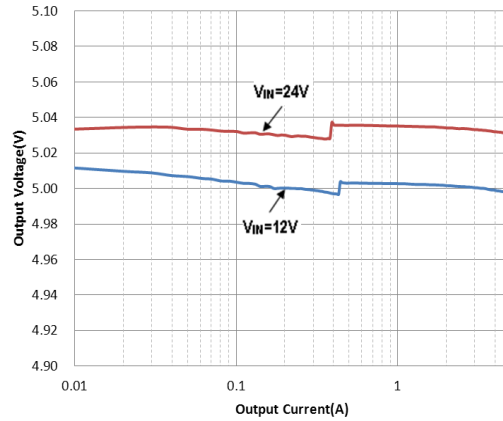

❖ PACKAGE OUTLINES

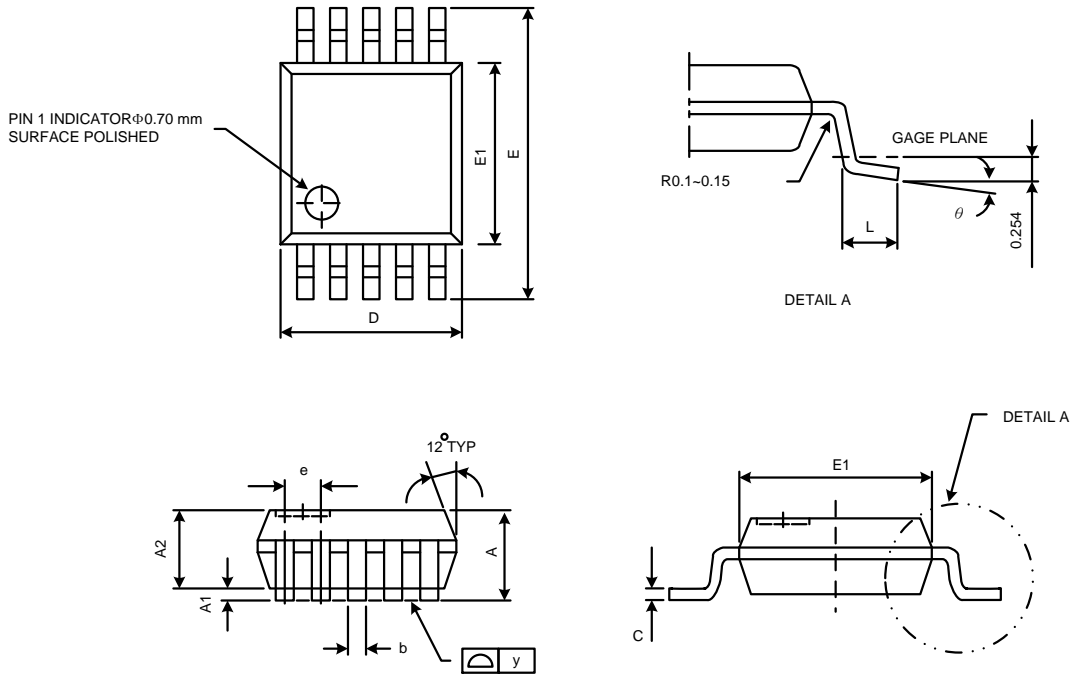

Symbol	Dimensions in Millimeters			Dimensions in Inches		
	Min.	Nom.	Max.	Min.	Nom.	Max.
A	-	-	1.1	-	-	0.043
A1	0	0.08	0.15	0	0.003	0.006
A2	0.75	0.86	0.95	0.03	0.033	0.037
b	0.17	0.21	0.33	0.009	0.012	0.015
C	0.08	0.16	0.23	0.003	0.006	0.009
D	2.9	3	3.1	0.114	0.118	0.122
E	4.8	4.9	5	0.189	0.193	0.197
E1	2.9	3	3.1	0.114	0.118	0.122
e	0.50 BSC			0.020 BSC		
L	0.4	0.6	0.8	0.016	0.024	0.031
y	-	-	0.1	-	-	0.004
θ	0°	3°	8°	0°	3°	8°

JEDEC outline: MO-187 BA

❖ Carrier tape dimension

MSOP-10

