

52KHz, 2A PWM Buck DC/DC Converter

❖ GENERAL DESCRIPTION

The AX3007C series are monolithic IC designed for a step-down DC/DC converter, and own the ability of driving a 2A load without additional transistor. It saves board space. The external shutdown function can be controlled by logic level and then come into standby mode. The internal compensation makes feedback control having good line and load regulation without external design. Regarding protected function, thermal shutdown is to prevent over temperature operating from damage, and current limit is against over current operating of the output switch. If current limit function occurs and V_{FB} is down below 0.4V, the switching frequency will be reduced.

The AX3007C series operates at a switching frequency of 52KHz thus allow smaller sized filter components than what would be needed with lower frequency switching regulators. The output version is an adjustable type. The chips are available in standard SOP-8L, SOP-8L-EP, TO252-5L and TO263-5L packages.

❖ FEATURES

- Output voltage: adjustable and fixed output versions.
- Adjustable version output voltage range is V_{FB} to 38V.
- 52KHz fixed switching frequency.
- Voltage mode non-synchronous PWM control.
- Thermal-shutdown and current-limit protection.
- ON/OFF shutdown control input.
- Short Circuit Protect (SCP).
- Operating voltage can be up to 40V.
- Output load current is up to 2A.
- SOP-8L, SOP-8L-EP, TO252-5L and TO263-5L Pb-Free packages.
- Low power standby mode.
- Built-in switching transistor on chip.
- RoHS and Halogen free compliance.

❖ BLOCK DIAGRAM

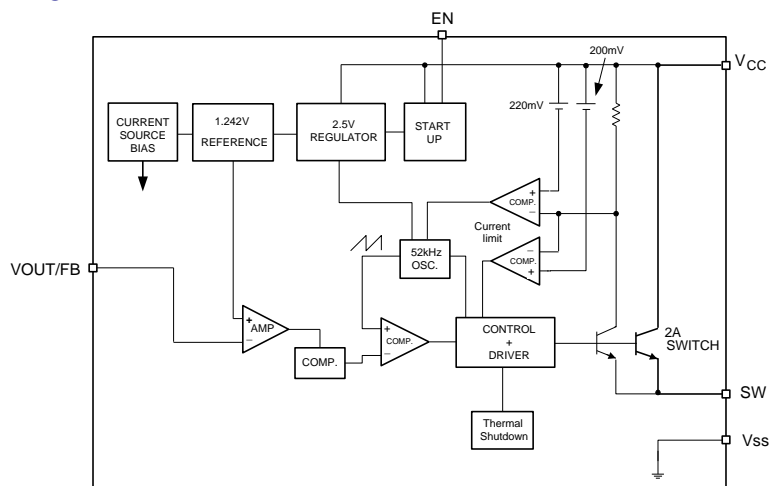

❖ ABSOLUTE MAXIMUM RATINGS

| Characteristics | | Symbol | Rating | Unit |
|---|-----------|---------------|-----------------------------|------|
| Maximum Supply Voltage | | V_{CC} | +45 | V |
| ON/OFF Pin Input Voltage | | V_{EN} | -0.3 to V_{CC} | V |
| Feedback Pin Voltage | | V_{FB} | -0.3 to 12 | V |
| Output Voltage to Ground | | V_{OUT} | -0.8 | V |
| Power Dissipation Internally limited | | PD | $(T_J - T_A) / \theta_{JA}$ | W |
| Storage Temperature Range | | T_{ST} | -65 to +165 | °C |
| Junction Temperature Range | | T_J | -40 to +150 | °C |
| Operating Supply Voltage | | V_{OP} | +4.5 to +40 | V |
| Thermal Resistance from Junction to case | SOP-8L | θ_{JC} | 20 | °C/W |
| | SOP-8L-EP | | 15 | |
| | TO263 | | 3.5 | |
| | TO252 | | 10 | |
| Thermal Resistance from Junction to ambient | SOP-8L | θ_{JA} | 60 | °C/W |
| | SOP-8L-EP | | 50 | |
| | TO263 | | 25 | |
| | TO252 | | 45 | |

Note: θ_{JA} is measured with the PCB copper area (need connect to V_{SS} , EP or Tap pins) of approximately 1.5 in² (Multi-layer).

❖ ELECTRICAL CHARACTERISTICS

(Unless otherwise specified, $T_A=25^\circ\text{C}$, $V_{CC}=12\text{V}$ for 3.3V, 5V, adjustable version and $V_{CC}=18\text{V}$ for the 12V version. $I_{OUT} = 0.2\text{A}$)

| Characteristics | Symbol | Conditions | Min | Typ | Max | Units |
|---|-------------------|---|-------|-------|-------|-------|
| Quiescent Current | I_Q | $V_{FB}=1.5\text{V}$ for Adjustable version force driver off | - | 4 | 8 | mA |
| Feedback voltage | V_{FB} | $I_{OUT}=0.2\text{A}$ (Adjustable version) | 1.230 | 1.242 | 1.255 | V |
| Feedback bias current | I_{FB} | $V_{FB}=1.5\text{V}$ | - | -10 | -500 | nA |
| Output Voltage | V_{OUT} | $I_{OUT}=0.2\text{A}$ (Fixed version) | 5.08 | 5.15 | 5.20 | V |
| Shutdown supply Current | I_{SD} | EN pin=5V, $V_{CC}=40\text{V}$ | - | 100 | 200 | uA |
| Oscillator frequency | F_{OSC} | | 40 | 52 | 65 | KHz |
| Oscillator frequency of short circuit protect | F_{SCP} | $V_{FB}<0.4\text{V}$ (Adjustable version) or $V_{OUT}=0\text{V}$ (Fixed Version) | - | 20 | - | KHz |
| Max. Duty Cycle (ON) | DC | $V_{FB}=0\text{V}$ force driver on | - | 100 | - | % |
| Min. Duty Cycle (OFF) | | $V_{FB}=1.5\text{V}$ for Adjustable version force driver off | - | 0 | - | |
| Current limit | I_{CL} | Pear current, No outside circuit $V_{FB}=0\text{V}$ force driver on | 2.2 | - | - | A |
| Line Regulation | ΔV_{Line} | $V_{CC} = 7.5\sim 40\text{V}$, $I_{OUT} = 10\text{mA}$ | - | 0.15 | 0.5 | % |
| Load Regulation | ΔV_{Load} | $I_{OUT} = 0.2$ to 2A | - | 0.1 | 0.5 | % |
| Saturation voltage | V_{SAT} | $I_{OUT}=2\text{A}$, No outside circuit $V_{FB}=0\text{V}$ force driver on | - | 1.0 | 1.2 | V |

❖ **ELECTRICAL CHARACTERISTICS (CONTINUOUS)**

(Unless otherwise specified, T_A=25°C, V_{CC}=12V for 3.3V, 5V, adjustable version and V_{CC}=18V for the 12V version. I_{OUT} = 0.2A)

| | | | | | | |
|---|-------------------|--|-----|-------|------|----|
| SW pin leakage current SW Pin=0V | I _{SW L} | No outside circuit V _{FB} =1.5V for Adjustable version force driver off | - | - | -200 | uA |
| SW pin leakage current SW pin=-0.8V | | V _{CC} =40V force driver off | - | -5 | - | mA |
| EN pin logic input threshold voltage | V _{IL} | Low (regulator ON) | - | 1.3 | 0.6 | V |
| | V _{IH} | High (regulator OFF) | 2.0 | | - | |
| EN pin logic input current | I _H | V _{EN} =2.5V (OFF) | - | -0.1 | -10 | uA |
| EN pin input current | I _L | V _{EN} =0.5V (ON) | - | -0.01 | -1.5 | |
| Thermal shutdown Temp | T _{SD} | | - | 150 | - | °C |

❖ **APPLICATION CIRCUIT**

(1) **Adjustable Output Voltage Version**

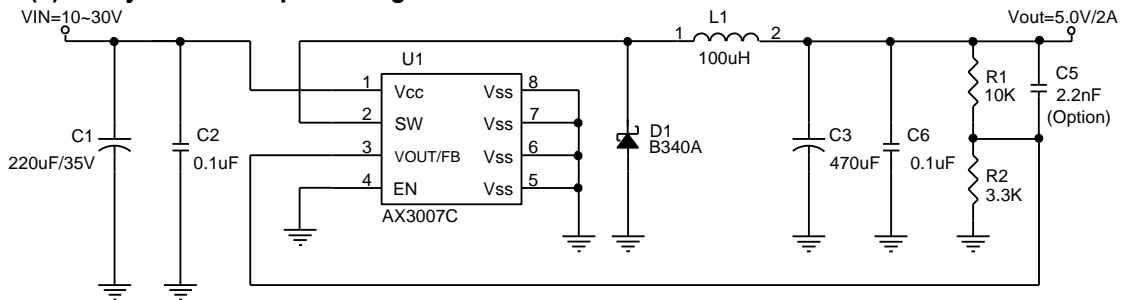

$$V_{OUT} = V_{FB} \times \left(1 + \frac{R1}{R2}\right), V_{FB} = 1.242V, R2 = 1K \sim 3.9K$$

(2) **Fixed Output Voltage Version**

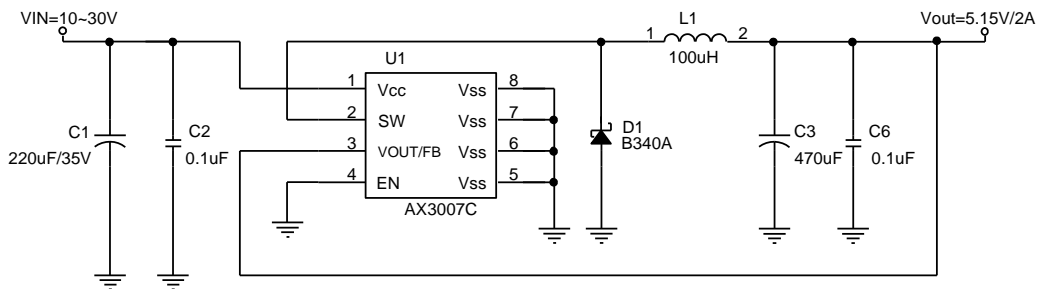

❖ **FUNCTION DESCRIPTION**

Pin Functions

V_{CC}

This is the positive input supply for the IC switching regulator. A suitable input bypass capacitor must be presented at this pin to minimize voltage transients and to supply the switching currents needed by the regulator.

V_{SS}
Circuit ground.

SW

Internal switch. The voltage at this pin switches between $(+V_{CC} - V_{SAT})$ and approximately $-0.5V$, with a duty cycle of approximately V_{OUT} / V_{CC} . To minimize coupling to sensitive circuitry, the PC board copper area connected to this pin should be minimized.

Feedback (adjustable version only)

Sense the regulated output voltage to complete the feedback loop.

EN

Allow the switching regulator circuit to be shutdown using logic level signals thus dropping the total input supply current to approximately 100uA. Pulling this pin below a threshold voltage of approximately 1.3V turns the regulator on, and pulling this pin above 1.3V (up to a maximum of V_{CC}) shuts the regulator down. If this shutdown feature is not needed, the EN pin can be wired to the ground pin.

Thermal Considerations

The SOP-8L package needs a heat sink under most conditions. The size of the heat sink depends on the input voltage, the output voltage, the load current and the ambient temperature. The AX3007C junction temperature rises above ambient temperature for a 2A load and different input and output voltages.

The data for these curves was taken with the AX3007C (SOP-8L package) operating as a buck-switching regulator in an ambient temperature of 25°C (still air). These temperature increments are all approximate and are affected by many factors. Higher ambient temperatures require more heat sinker.

For the best thermal performance, wide copper traces and generous amounts of printed circuit board copper (need connect to the V_{SS} pins) should be used in the board layout, (One exception is the SW(switch) pin, which should not have large areas of copper.) Large areas of copper provide the best transfer of heat (lower thermal resistance) to the surrounding air, and moving air lowers the thermal resistance even further.

Package thermal resistance and junction temperature increments are all approximate. The increments are affected by a lot of factors. Some of these factors include board size, shape, thickness, position, location, and even board temperature. Other factors are, trace width, total printed circuit copper area, copper thickness, single or double-sided, multi-layer board and the amount of solder on the board.

The effectiveness of the PC board to dissipate heat also depends on the size, quantity and spacing of other components on the board, as well as whether the surrounding air is still or moving. Furthermore, some of these components such as the catch diode will add heat to the PC board and the heat can vary as the input voltage changes. For the inductor, depending on the physical size, type of core material and the DC resistance, it could either act as a heat sink taking heat away from the board, or it could add heat to the board.

❖ TYPICAL CHARACTERISTICS

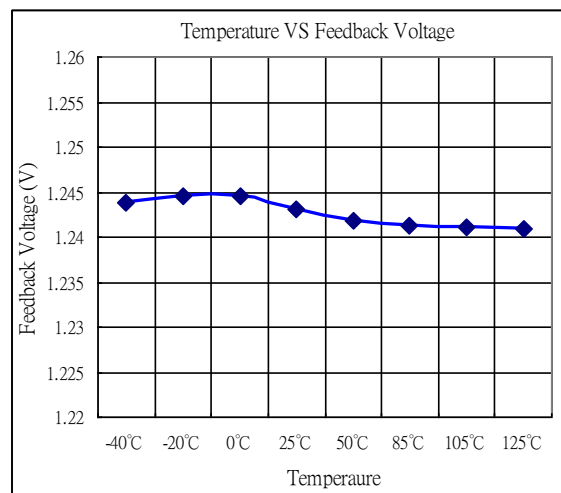
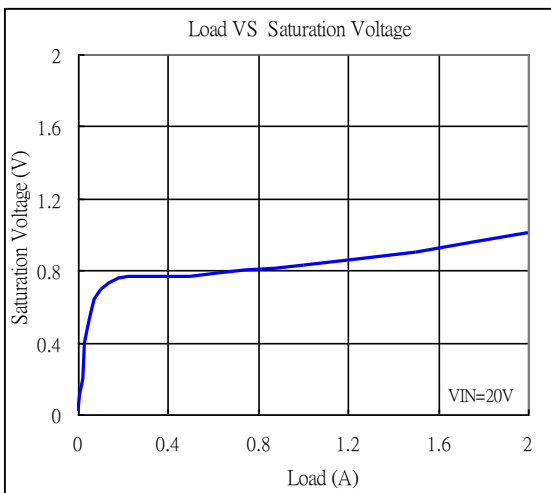
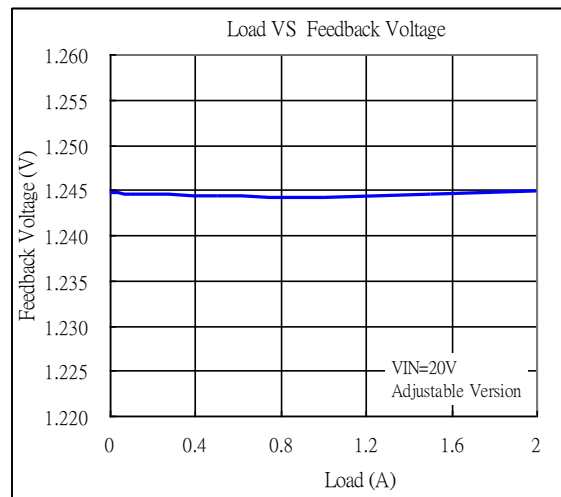
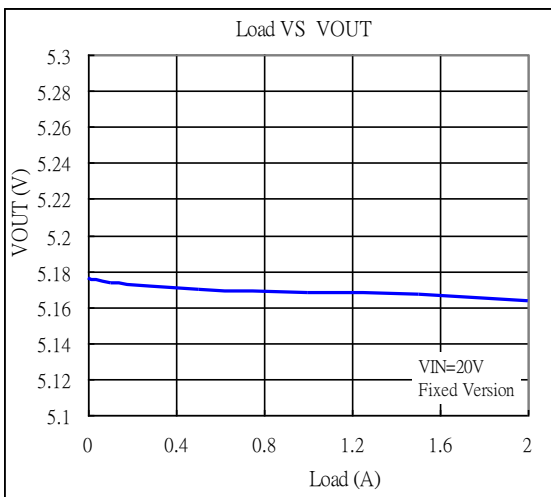
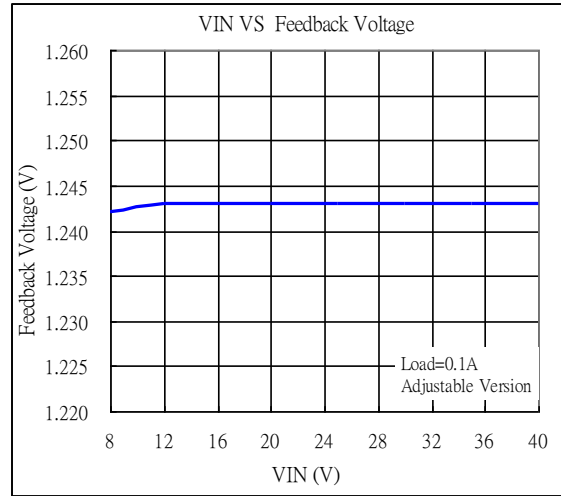
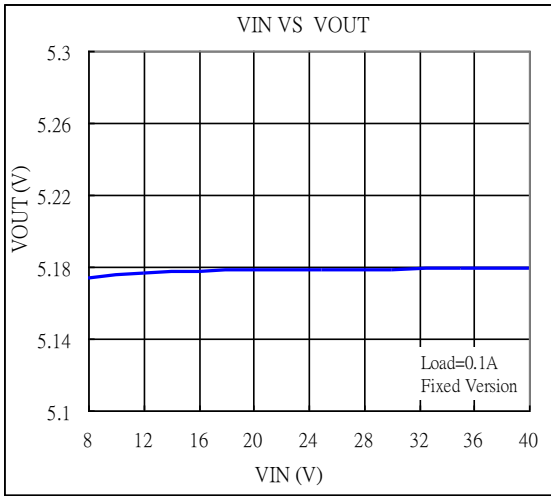

❖ TYPICAL CHARACTERISTICS (CONTINUOUS)

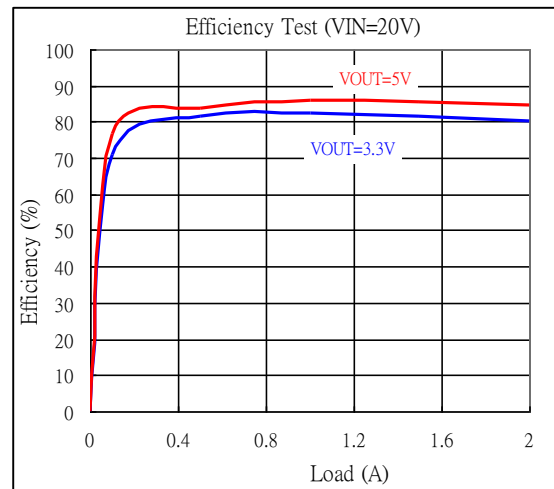
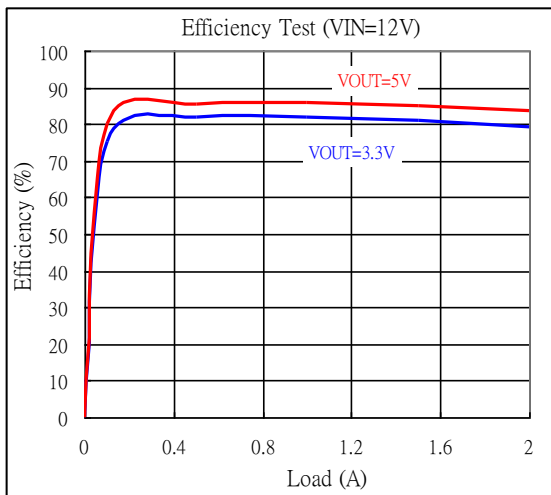

Power on test wave
(VIN=12V, VOUT=5V, IOUT=1A)

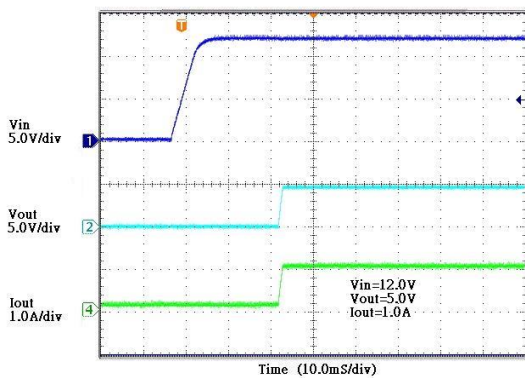

EN on test wave
(VIN=12V, VOUT=5V, IOUT=1A)

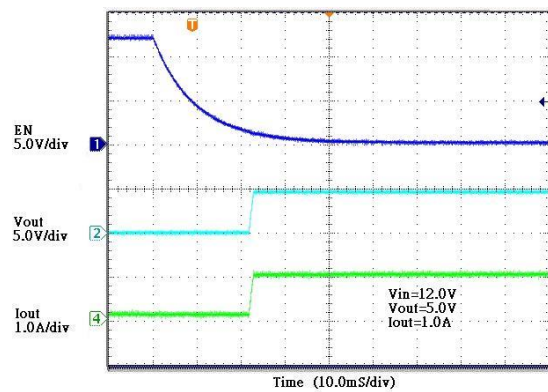

Load Transient Response
(VIN=12V, VOUT=5V, IOUT=0.2~2A)

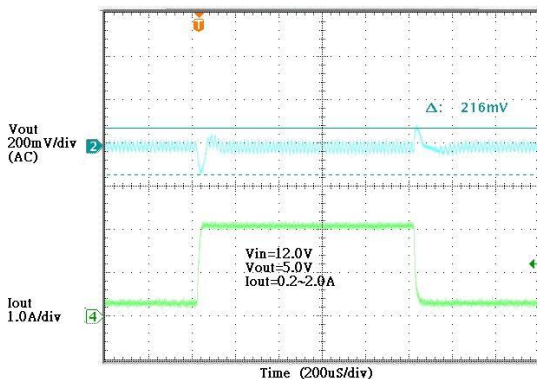

Load Transient Response
(VIN=30V, VOUT=5V, IOUT=0.2~2A)

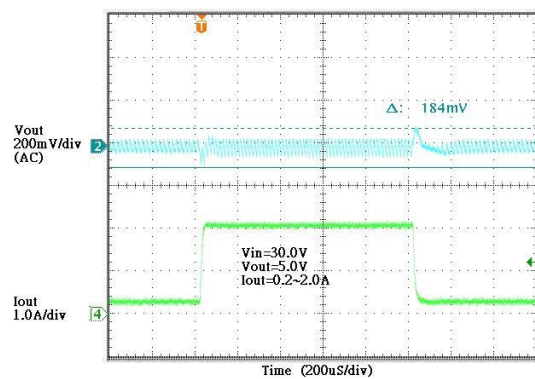

❖ PACKAGE OUTLINES

(1) SOP-8L

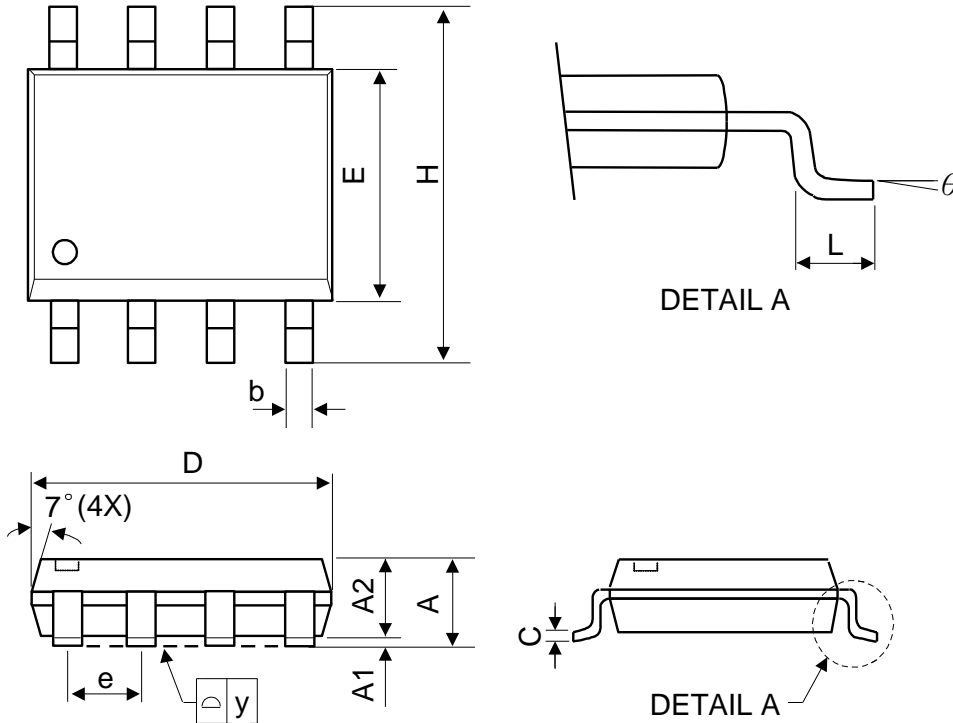

| Symbol | Dimensions in Millimeters | | | Dimensions in Inches | | |
|--------|---------------------------|------|------|----------------------|-------|-------|
| | Min. | Nom. | Max. | Min. | Nom. | Max. |
| A | - | - | 1.75 | - | - | 0.069 |
| A1 | 0.1 | - | 0.25 | 0.04 | - | 0.1 |
| A2 | 1.25 | - | - | 0.049 | - | - |
| C | 0.1 | 0.2 | 0.25 | 0.0075 | 0.008 | 0.01 |
| D | 4.7 | 4.9 | 5.1 | 0.185 | 0.193 | 0.2 |
| E | 3.7 | 3.9 | 4.1 | 0.146 | 0.154 | 0.161 |
| H | 5.8 | 6 | 6.2 | 0.228 | 0.236 | 0.244 |
| L | 0.4 | - | 1.27 | 0.015 | - | 0.05 |
| b | 0.31 | 0.41 | 0.51 | 0.012 | 0.016 | 0.02 |
| e | 1.27 BSC | | | 0.050 BSC | | |
| y | - | - | 0.1 | - | - | 0.004 |
| θ | 0° | - | 8° | 0° | - | 8° |

Mold flash shall not exceed 0.25mm per side

JEDEC outline: MS-012 AA

(2) SOP-8L-EP

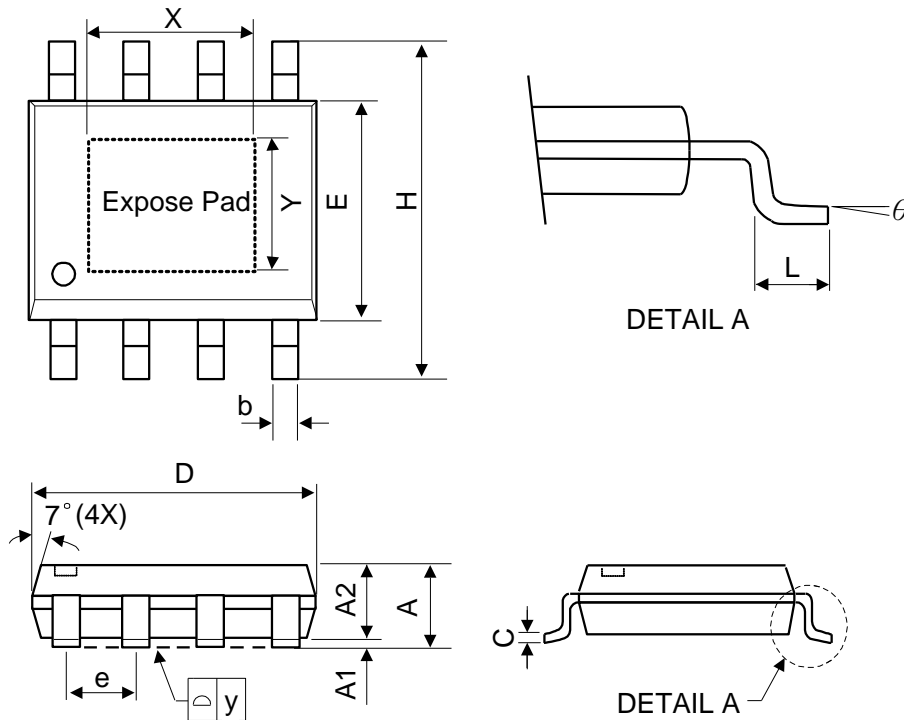

| Symbol | Dimensions in Millimeters | | | Dimensions in Inches | | |
|--------|---------------------------|------|------|----------------------|-------|-------|
| | Min. | Nom. | Max. | Min. | Nom. | Max. |
| A | - | - | 1.75 | - | - | 0.069 |
| A1 | 0 | - | 0.15 | 0 | - | 0.06 |
| A2 | 1.25 | - | - | 0.049 | - | - |
| C | 0.1 | 0.2 | 0.25 | 0.0075 | 0.008 | 0.01 |
| D | 4.7 | 4.9 | 5.1 | 0.185 | 0.193 | 0.2 |
| E | 3.7 | 3.9 | 4.1 | 0.146 | 0.154 | 0.161 |
| H | 5.8 | 6 | 6.2 | 0.228 | 0.236 | 0.244 |
| L | 0.4 | - | 1.27 | 0.015 | - | 0.05 |
| b | 0.31 | 0.41 | 0.51 | 0.012 | 0.016 | 0.02 |
| e | 1.27 BSC | | | 0.050 BSC | | |
| y | - | - | 0.1 | - | - | 0.004 |
| X | - | 2.34 | - | - | 0.092 | - |
| Y | - | 2.34 | - | - | 0.092 | - |
| θ | 0° | - | 8° | 0° | - | 8° |

Mold flash shall not exceed 0.25mm per side
JEDEC outline: MS-012 BA

(3) T0252-5L

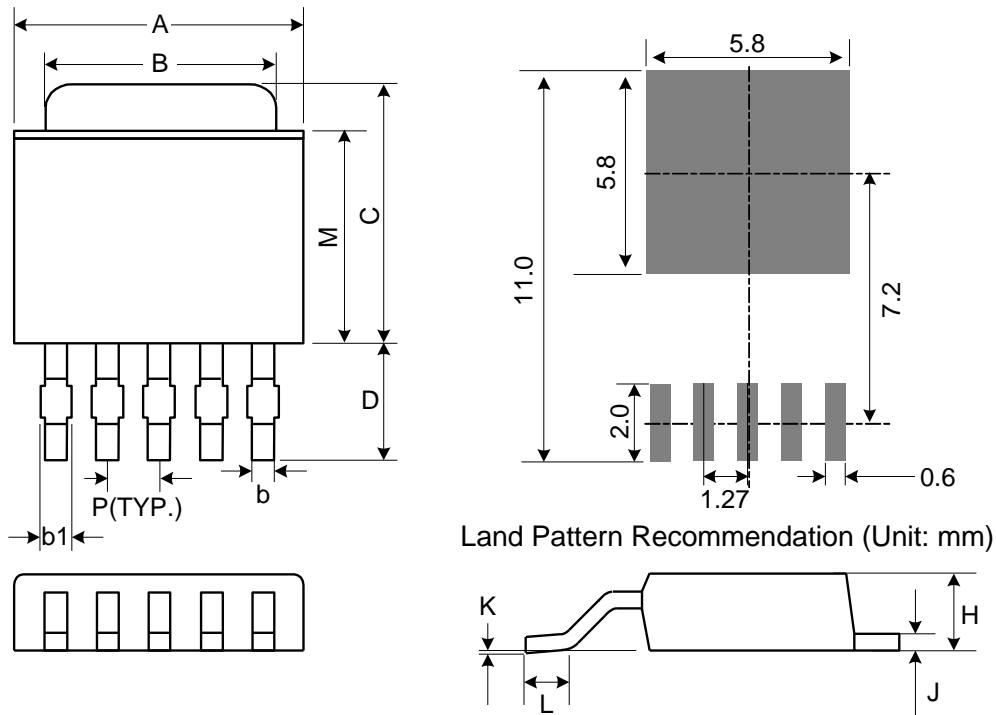

| Symbol | Dimensions in Millimeters | | | Dimensions in Inches | | |
|--------|---------------------------|------|------|----------------------|-------|-------|
| | Min. | Nom. | Max. | Min. | Nom. | Max. |
| A | 6.35 | 6.6 | 6.73 | 0.250 | 0.260 | 0.265 |
| B | 5.21 | 5.33 | 5.46 | 0.205 | 0.210 | 0.215 |
| C | 6.86 | 7.24 | 7.62 | 0.270 | 0.285 | 0.300 |
| D | 2.67 REF | | | 0.105 REF | | |
| P | 1.27 REF | | | 0.050 REF | | |
| H | 2.18 | 2.29 | 2.39 | 0.086 | 0.090 | 0.094 |
| J | 0.46 | 0.51 | 0.58 | 0.018 | 0.020 | 0.023 |
| K | 0.00 | 0.08 | 0.13 | 0.000 | 0.003 | 0.005 |
| L | 1.40 | 1.60 | 1.78 | 0.055 | 0.063 | 0.070 |
| M | 5.33 | 5.46 | 5.59 | 0.210 | 0.215 | 0.220 |
| b | 0.38 | 0.56 | 0.71 | 0.015 | 0.022 | 0.028 |
| b1 | 0.38 | 0.53 | 0.66 | 0.015 | 0.021 | 0.026 |

Mold flash shall not exceed 0.005inch per side

(4) TO263-5L

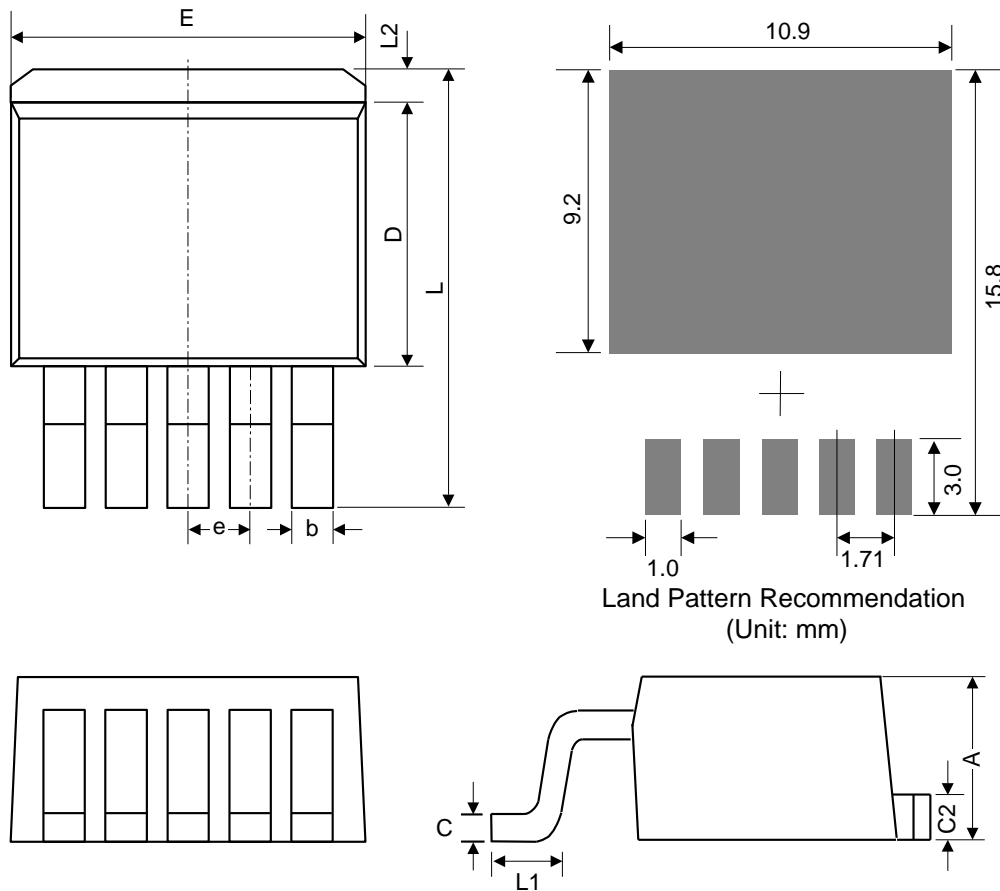

Land Pattern Recommendation
(Unit: mm)

| Symbol | Dimensions in Millimeters | | | Dimensions in Inches | | |
|--------|---------------------------|------|------|----------------------|-------|-------|
| | Min. | Nom. | Max. | Min. | Nom. | Max. |
| A | 4.06 | 4.45 | 4.83 | 0.16 | 0.175 | 0.19 |
| b | 0.51 | 0.76 | 0.99 | 0.02 | 0.03 | 0.039 |
| C | 0.38 | 0.56 | 0.74 | 0.015 | 0.022 | 0.029 |
| C2 | 1.14 | 1.4 | 1.65 | 0.045 | 0.055 | 0.065 |
| D | 8.38 | 9.02 | 9.65 | 0.33 | 0.355 | 0.38 |
| E | 9.65 | 10.2 | 10.7 | 0.38 | 0.4 | 0.42 |
| e | 1.70 BSC | | | 0.067 BSC | | |
| L | 14.6 | 15.2 | 15.9 | 0.575 | 0.6 | 0.625 |
| L1 | 1.78 | 2.29 | 2.79 | 0.07 | 0.09 | 0.11 |
| L2 | - | - | 1.68 | - | - | 0.066 |

Mold flash shall not exceed 0.005inch per side

JEDEC outline: TO-263 BA

❖ CARRIER TAPE DIMENSION

(1) SOP-8L

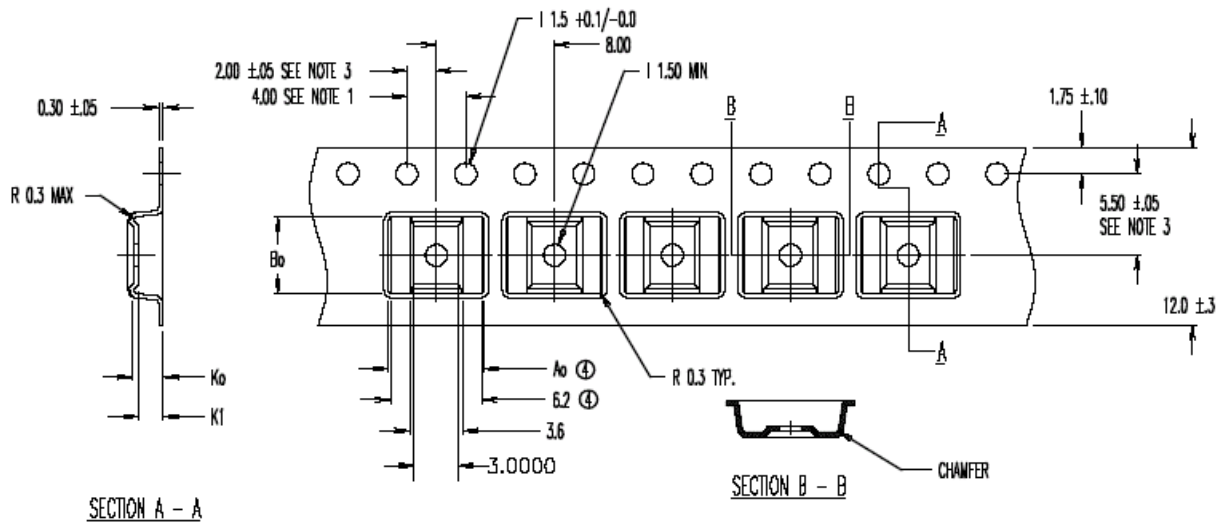

- ⊕ ⊕ Ap = 6.50
- Bo = 5.20
- Ko = 2.10
- K1 = 1.70

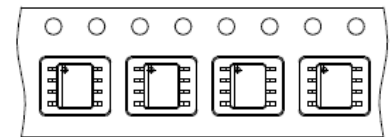
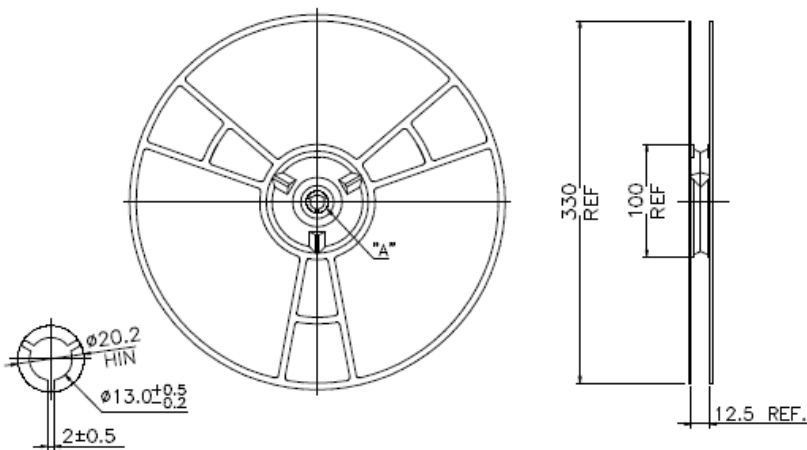

(2) SOP-8L-EP

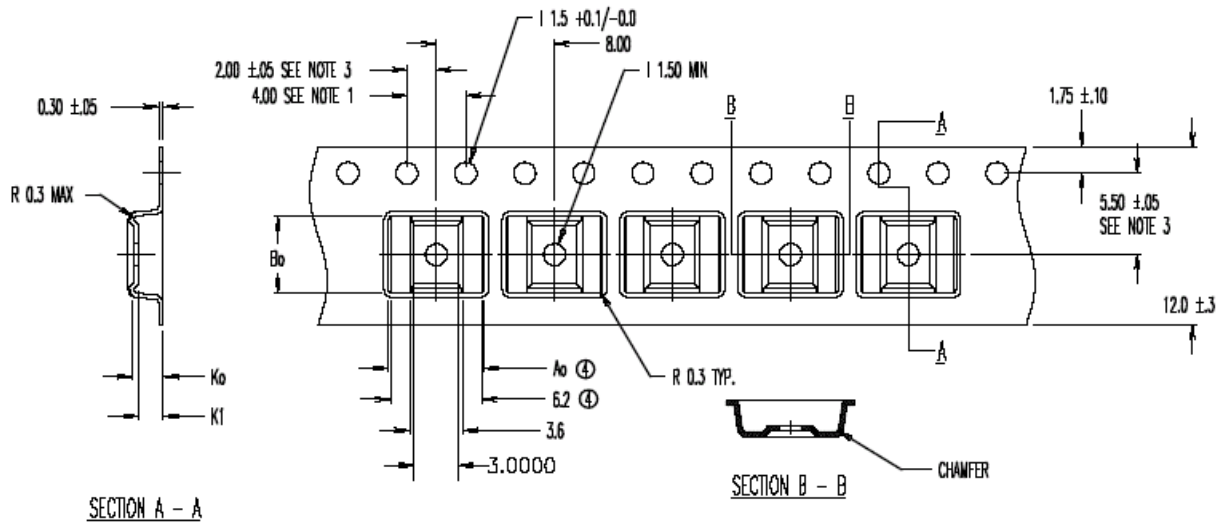

- Ⓢ A0 = 6.50
- Ⓢ B0 = 5.20
- Ⓢ K0 = 2.10
- Ⓢ K1 = 1.70

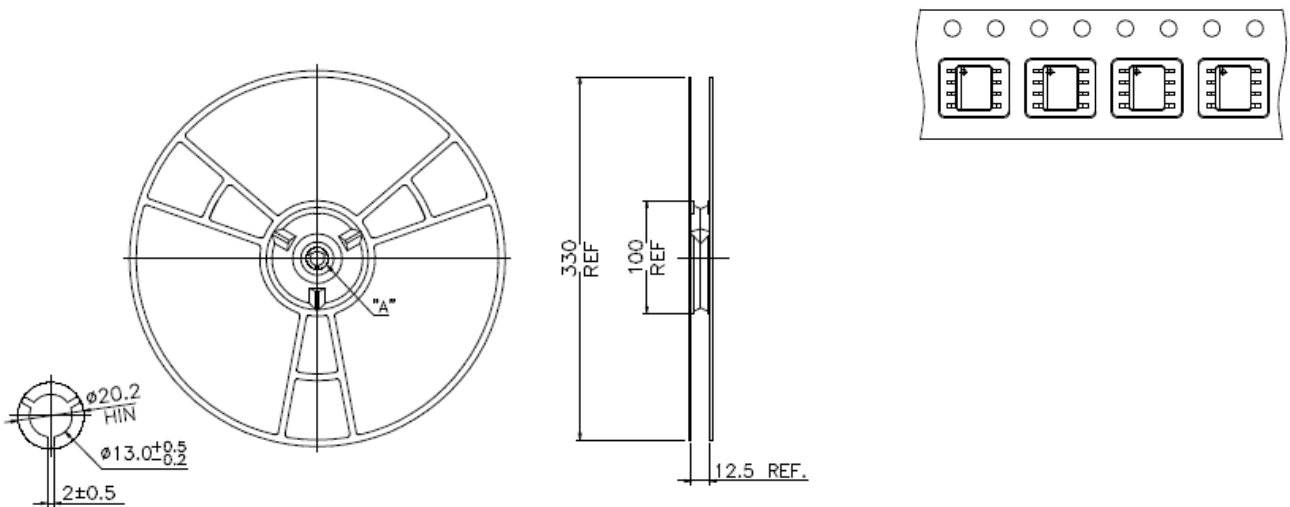

(3) T0252-5L

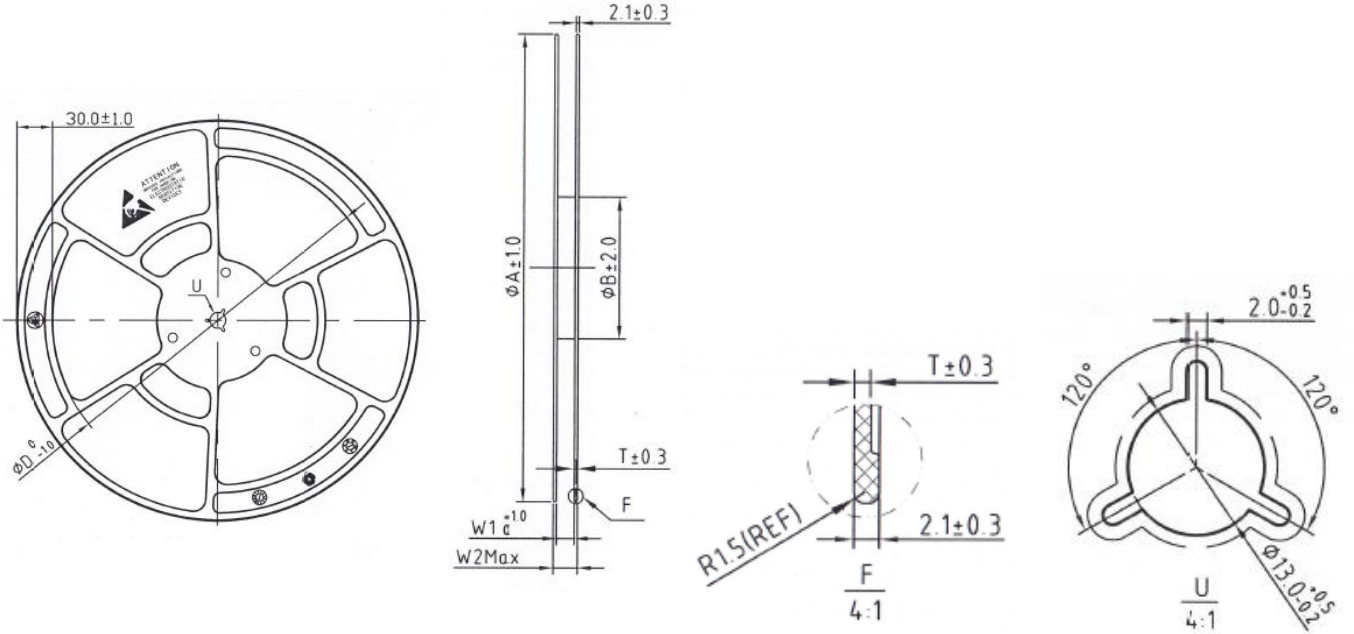

| 型號規格 | 適合載帶寬度 | 圓盤基本尺寸 | | | | | |
|--------------|-----------|--------|-------|------|-------|-----|-----|
| | | A | B(內徑) | W1 | W2Max | T | D |
| 13" - 12X100 | 12 / 12.2 | 330 | 100 | 12.4 | 18.4 | 1.5 | 270 |
| 13" - 16X100 | 16 | | | 16.4 | 22.4 | | |
| 13" - 24X100 | 24 | | | 24.4 | 30.4 | | |

(mm)

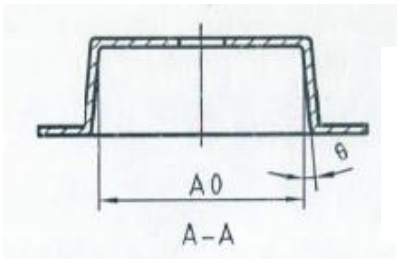
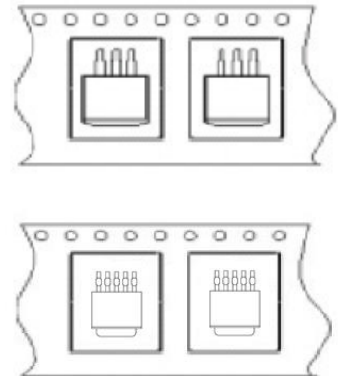
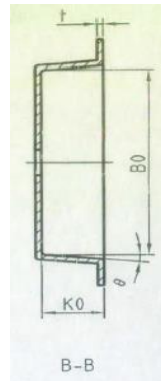
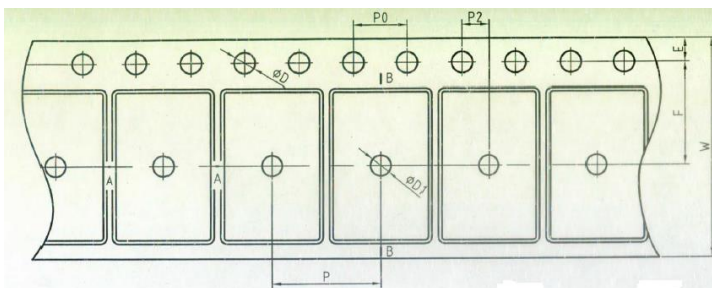

| | | | | | | |
|------------|-----------|----------------|-----------------------------------|------------------------------------|----------------|------------------|
| E | F | P ₂ | D | D ₁ | P ₀ | 10P ₀ |
| 1.75±0.10 | 7.50±0.10 | 2.00±0.10 | 1.50 ^{+0.1} ₀ | 1.50 ^{-0.25} ₀ | 4.00±0.10 | 40.0±0.20 |
| W | P | A ₀ | B ₀ | K ₀ | t | θ |
| 16.00±0.10 | 8.00±0.10 | 6.90±0.10 | 10.50±0.10 | 2.65±0.10 | 0.30±0.02 | 5°TYP |

(mm)

(4)TO263-5L

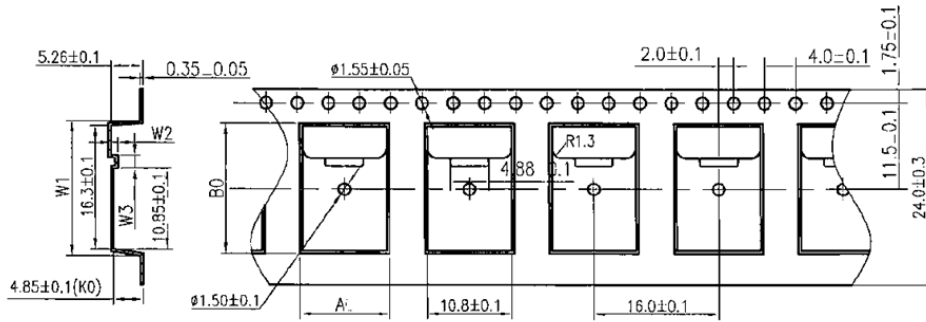

| | |
|----|----------|
| W1 | 17.2±0.1 |
| W2 | 1.8±0.1 |
| W3 | 0.85±0.1 |

(mm)

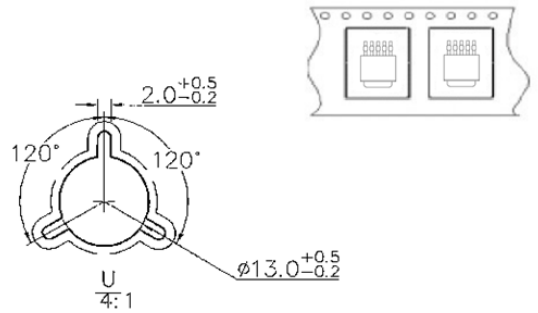
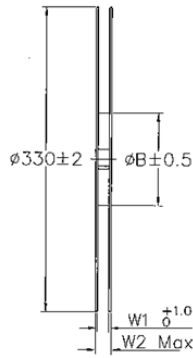
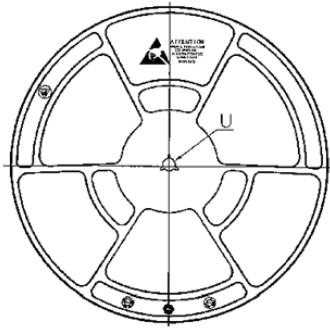

| 產品類別 | 載帶寬度 | B(內徑) | W1 | W2max |
|-------|------|-------|------|-------|
| TO263 | 24 | 100 | 24.4 | 30.4 |

(mm)