

40V, 1.7A, Boost for 10 White LED Driver

❖ GENERAL DESCRIPTION

The AX2016 is a step-up converter designed for driving up to 10 series white LEDs for backlighting application. The AX2016 uses current mode, 1MHz fixed frequency architecture to regulate the LED current, which is set through an external current sense resistor. Its low 300mV/250mV/200mV feedback voltage reduces power loss and improves efficiency. The OV pin monitors the output voltage and turns off the converter if an over-voltage condition is present due to an open circuit condition. The AX2016 includes under-voltage lockout, current limiting and thermal shutdown protection preventing damage in the event of an output overload. The driver is available in small 6-pin SOT-23 package.

❖ FEATURES

- 2.5V to 5.5V operating input voltage range
- Drives up to 10 series White LEDs
- 1MHz Fixed Switching Frequency
- Wide range for PWM dimming (200Hz to 200KHz)
- Internal 1.7A switching current limit
- Over Voltage Protection (OVP)
- Internal Soft-start Function
- Current limit and Thermal shutdown protection
- Under voltage Lockout
- Available in the 6-pin SOT-23 Package
- RoHS and Halogen free compliance

❖ BLOCK DIAGRAM

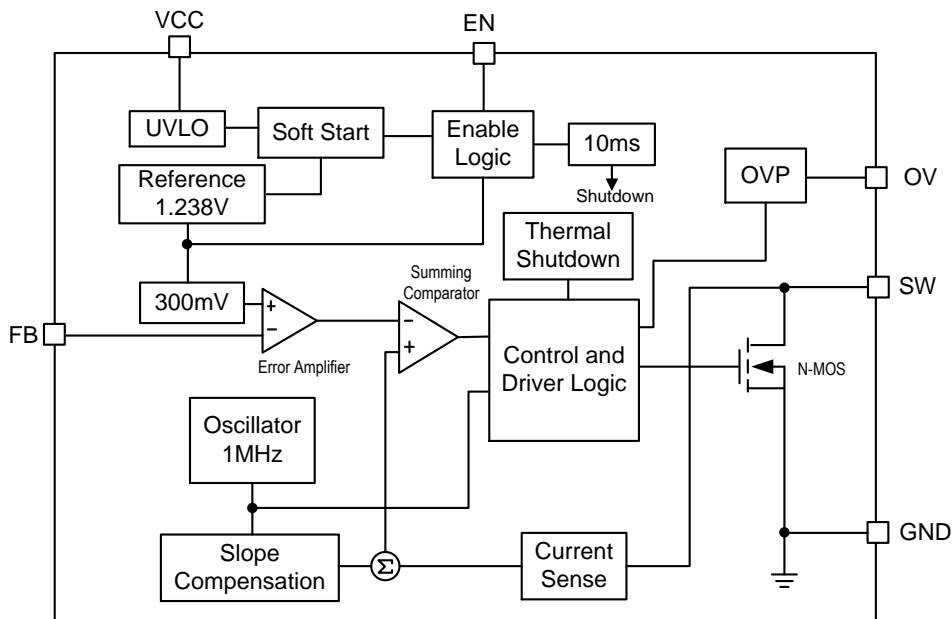

❖ PIN ASSIGNMENT

The package of AX2016 is SOT-23-6L; the pin assignment is given by:

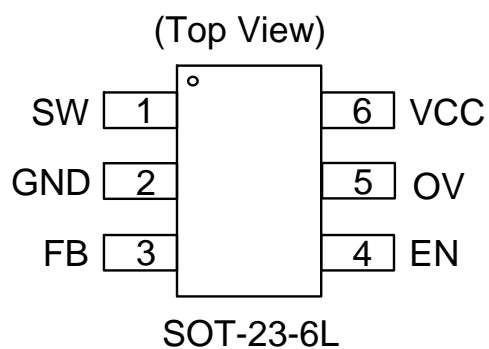

Name	Description
SW	Switch Output Pin
GND	Ground Pin
FB	Feedback Pin; Put a Resistor to GND to Setting the Current
EN	Enable with Dimming Pin; Internal Floating; Logic High Active
OV	OVP Sense Pin
VCC	Power Input Pin

❖ ORDER/MARKING INFORMATION

Order Information	Top Marking
<p>AX2016 XX X</p> <p>Package Type C: SOT-23-6L</p> <p>Packing Blank : Bag A : Taping</p>	<p>J M Y W X → ID Code: Internal</p> <p>Week: 01~26(A~Z) 27~52(a~z)</p> <p>Year: 8=2018 9=2019 B=2020 C=2021 D=2022 ⋮ Z = 2044</p> <p>AX2016</p>

❖ ABSOLUTE MAXIMUM RATINGS (at T_A=25°C)

Characteristics	Symbol	Rating	Unit
V _{CC} Pin Voltage	V _{CC}	-0.3 to 6	V
SW Pin Voltage	V _{SW}	-0.3 to 45	V
OV Pin Voltage	V _{OV}	-0.3 to 45	V
EN, FB Pin Voltage		-0.3 to 6	V
Power Dissipation	PD	(T _J -T _A) / θ _{JA}	W
Storage Temperature Range	T _{ST}	-65 to +150	°C
Operating Junction Temperature Range	T _{OP}	-40 to +125	°C
Thermal Resistance from Junction to case	θ _{JC}	130	°C/W
Thermal Resistance from Junction to ambient	θ _{JA}	250	°C/W

Note: θ_{JA} is measured with the PCB copper area of approximately 1 in² (Multi-layer).

❖ ELECTRICAL CHARACTERISTICS

 ($V_{CC}=5V$, $I_{OUT} = 20mA$, $T_A = 25^{\circ}C$, unless otherwise noted)

Characteristics		Symbol	Conditions	Min	Typ	Max	Units
Input Voltage Range		V_{CC}		2.5	-	5.5	V
Step-Up Voltage Range		V_{OUT}		3	-	40	V
OV Sense Voltage		V_{OV}			38		V
Under Voltage Lockout		U_{VLO}	Rising	-	2.2	2.4	V
UVLO Hysteresis				-	100	-	mV
Feedback Voltage		V_{FB}		285	300	315	mV
EN Threshold	Logic-High Voltage	V_{IH}		2.0	-	-	V
	Logic-Low Voltage	V_{IL}		-	-	0.4	V
EN Hysteresis				-	200	-	mV
Operating Quiescent Current		I_{CCQ}	$I_{OUT}= 0mA$, $V_{FB} =0.5V$	-	300	500	μA
Shutdown Current		I_{SD}	$V_{EN}=0V$, $t_{EN} > 20ms$	-	1	4	μA
N-Channel MOSFET Current Limit (Note1)		I_{LIM}	Duty=50%		1.7	-	A
MOSFET On-Resistance (Note1)		$R_{DS(on)}$		-	0.6	1.0	Ω
Maximum Duty Cycle		D_{MAX}		-	88	-	%
Line Regulation			$V_{CC} = 3V$ to $5V$	-	1	-	%
Switching Frequency		F_{OSC}		0.75	1	1.25	MHz
Dimming Clock Rate		F_{DIM}		0.2	-	200	KHz
FB Input Leakage Current		I_{FB-LKG}	$V_{FB} = 0.5V$	-	0.01	100	nA
SW Leakage Current		I_{SWL}	$V_{LX} = 30V$, $V_{FB} =0.5V$	-	-	1	μA
EN Input Leakage Current		$I_{EN-LKG1}$	$V_{EN}= V_{CC}$	-	1.5	3	μA
		$I_{EN-LKG2}$	$V_{EN}= GND$	-	-	1	μA
Shutdown Delay		T_{SHDN}		-	10	-	mS
Thermal Shutdown		T_{SD}		-	160	-	$^{\circ}C$
Thermal Shutdown Hysteresis		T_{SH}		-	30	-	

Note1: Guaranteed by design.

❖ APPLICATION CIRCUIT

(1) 10 series LED application

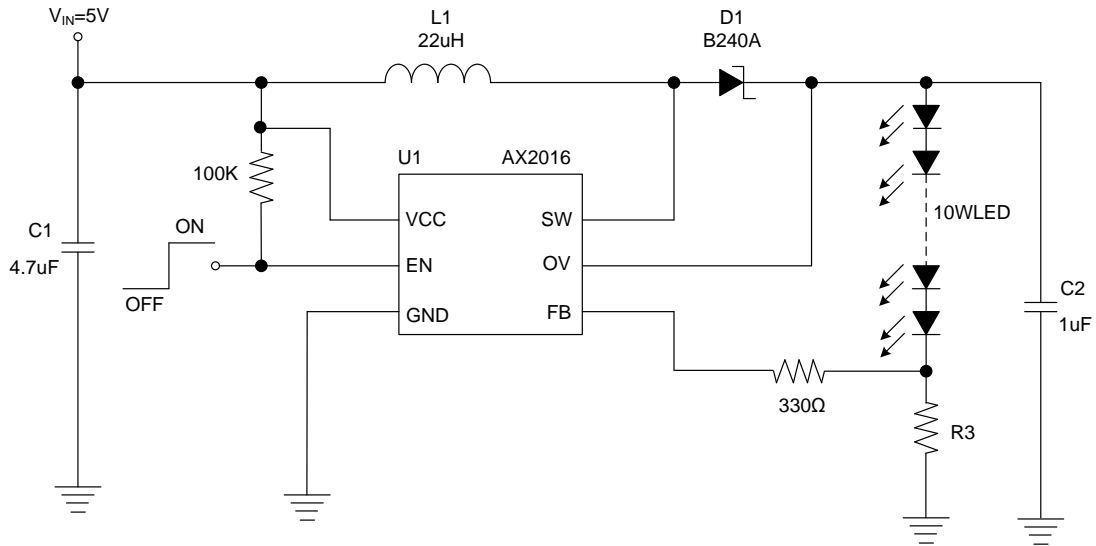

$$I_{LED} = V_{FB} / R_3, V_{FB} = 300\text{mV (AX2016)}$$

$$V_{FB} = 200\text{mV (AX2016A)}$$

(2) LED Dimming application

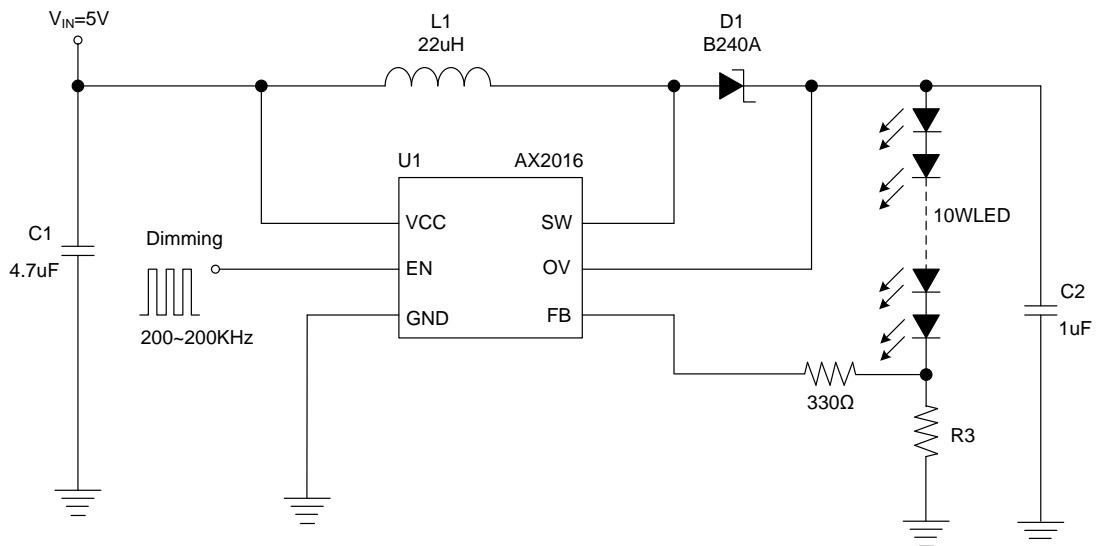

$$I_{LED} = V_{FB} / R_3, V_{FB} = 300\text{mV (AX2016)}$$

$$V_{FB} = 200\text{mV (AX2016A)}$$

❖ **APPLICATION INFORMATION**

Setting the I_{LED} Current

Application circuit item shows the basic application circuit with AX2016 adjustable output version. The external resistor sets the LED output current according to the following equation:

$$I_{LED} = (V_{FB} / R3)$$

Part No.	I _{LED}	R3	
AX2016	20mA	15Ω	6mW
	350mA	0.857Ω	105mW

Over Voltage Protection

The Over Voltage Protection is detected by a junction breakdown detecting circuit. Once V_{OUT} goes over the detecting voltage, SW pin stops switching and the power N-MOSFET will be turned off. Then, the V_{OUT} will be clamped to be near V_{OVP}.

Under Voltage Lockout (UVLO)

To avoid mis-operation of the device at low input voltages an under voltage lockout is included that disables the device, if the input voltage falls below (2.25V-100mV).

Input Capacitor Selection

The input capacitor reduces the surge current drawn from the input and switching noise from the device. The input capacitor impedance at the switching frequency shall be less than input source impedance to prevent high frequency switching current passing to the input. A low ESR input capacitor sized for maximum RMS current must be used. Ceramic capacitors with X5R or X7R dielectrics are highly recommended because of their low ESR and small temperature coefficients. A 4.7μF ceramic capacitor for most applications is sufficient. For a lower output power requirement application, this value can be decreased.

Output Capacitor Selection

The output capacitor is required to keep the output voltage ripple small and to ensure regulation loop stability. The output capacitor must have low impedance at the switching frequency. Ceramic capacitors with X5R or X7R dielectrics are recommended due to their low ESR and high ripple current. A 1uF ceramic capacitors works for most of the applications. Higher capacitor values can be used to improve the load transient response.

❖ TYPICAL CHARACTERISTICS

Efficiency vs. Output Current

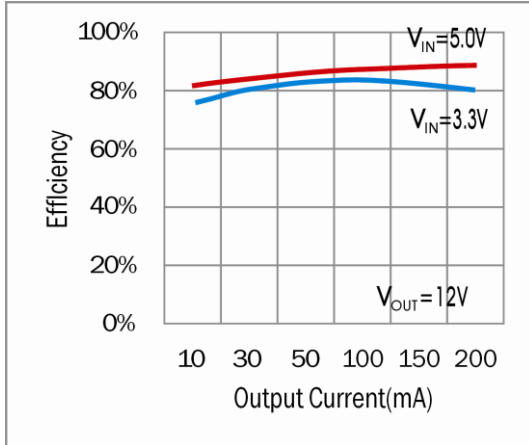

Efficiency vs. Input Voltage

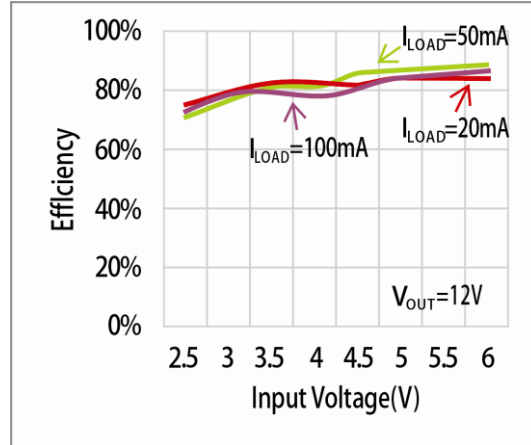

Output Voltage vs. Output Current

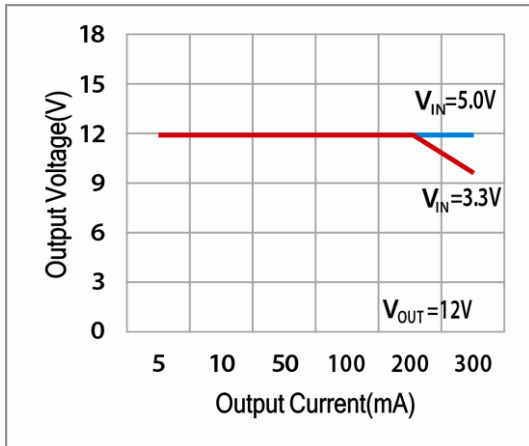

Quiescent Current vs. Input Voltage

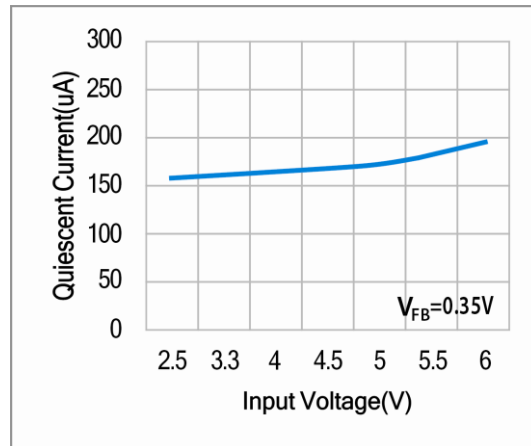

Frequency vs. Input Voltage

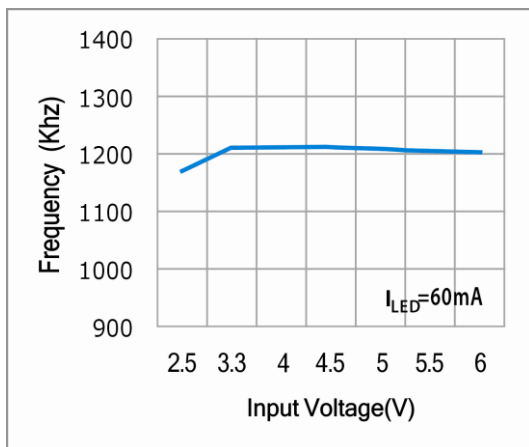

Frequency vs. Temperature

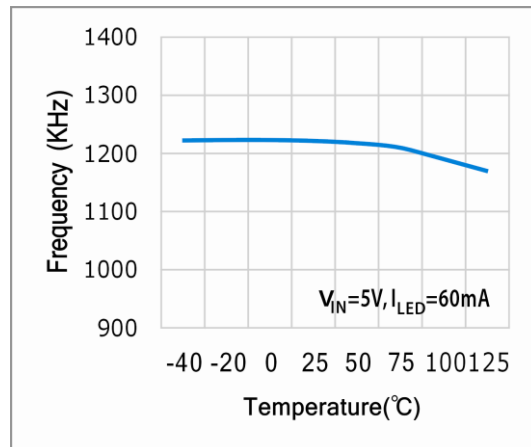

❖ TYPICAL CHARACTERISTICS (CONTINUOUS)

Reference Voltage vs. Input Voltage

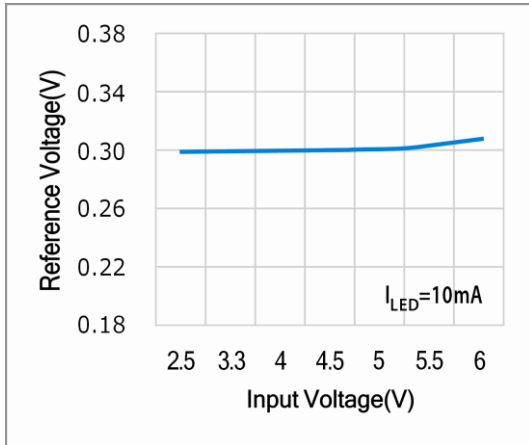

Reference Voltage vs. Temperature

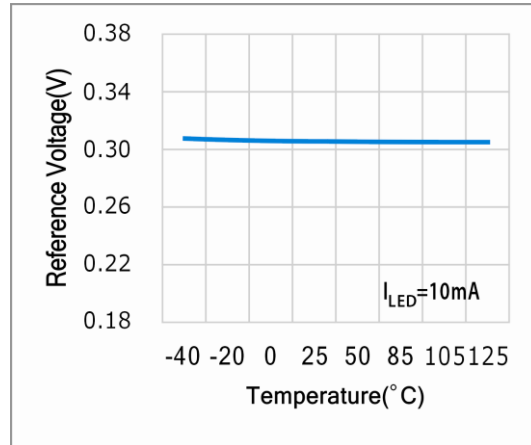

LED Current vs. Duty

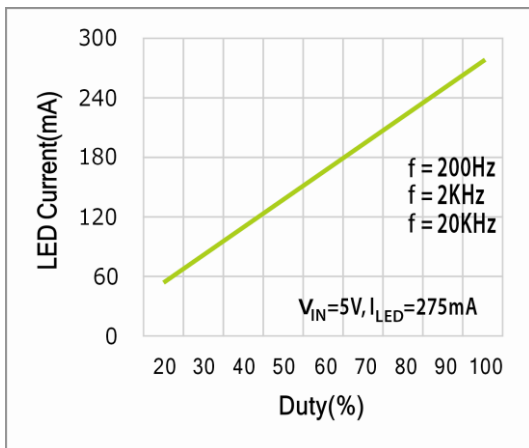

Enable Threshold vs. Input Voltage

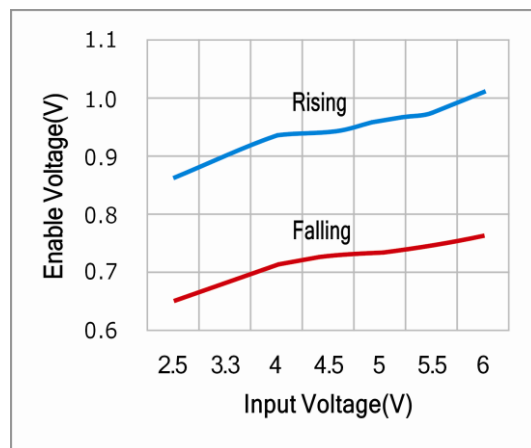

❖ TYPICAL CHARACTERISTICS (CONTINUOUS)

Power ON from V_{IN}

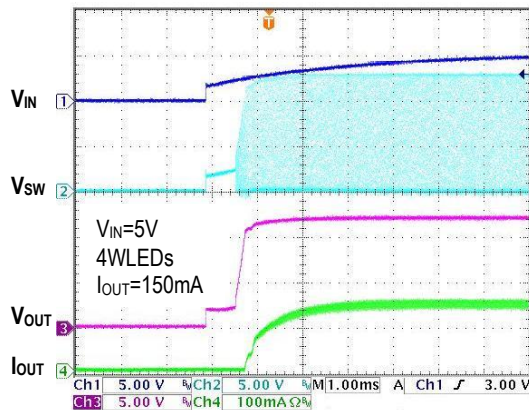

Power ON from EN

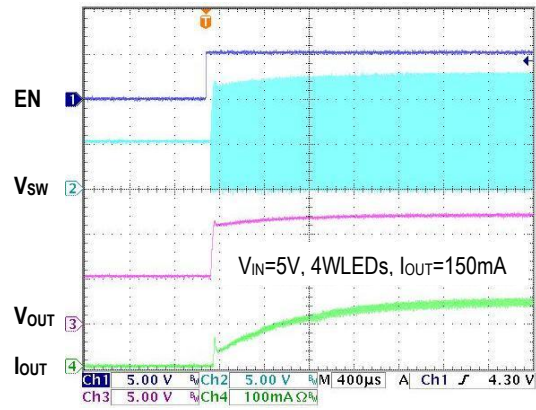

Steady State Operation

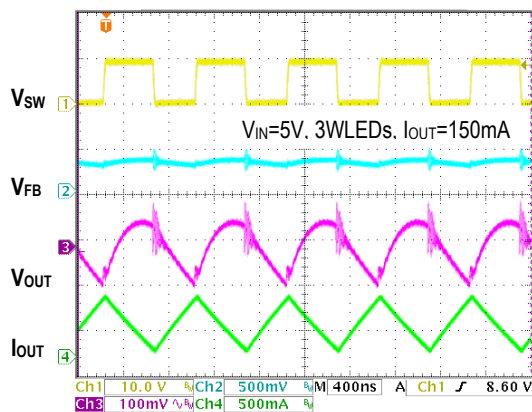

(V_{OUT} , I_{OUT} : measured by AC coupled mode)

Normal Operation into OVP

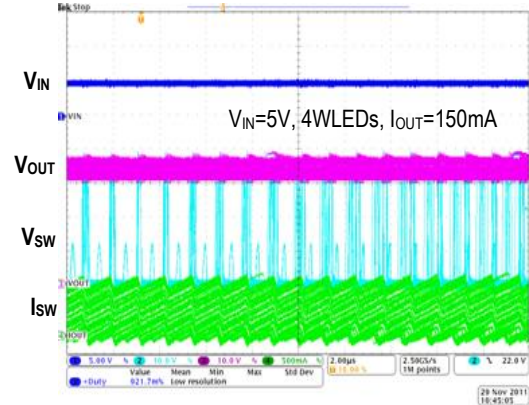

PWM Dimming from EN (200Hz)

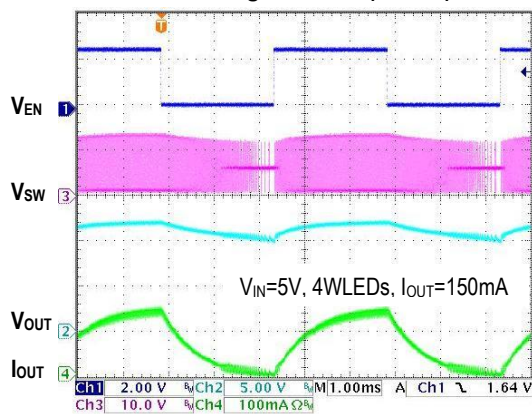

PWM Dimming from EN (20KHz)

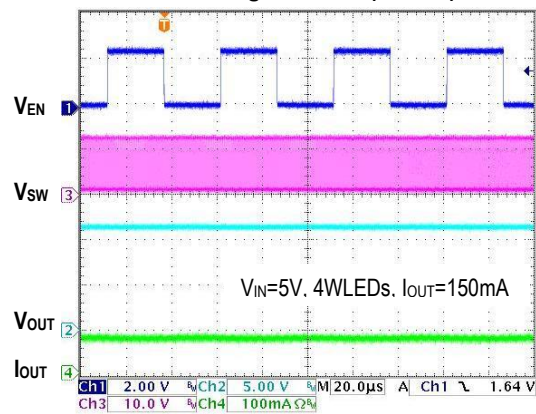

❖ PACKAGE OUTLINES

(1) SOT-23-6L

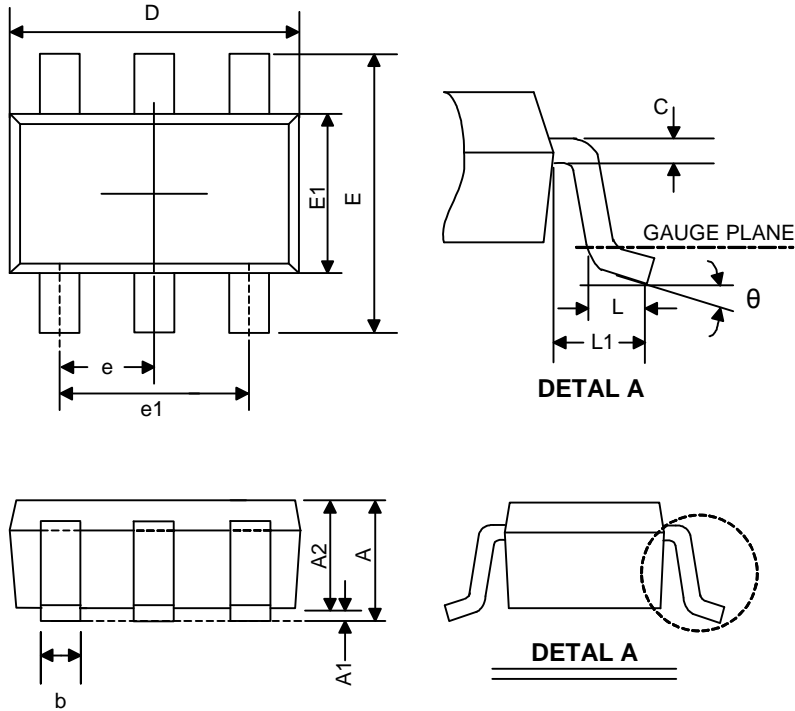

Symbol	Dimensions in Millimeters			Dimensions in Inches		
	Min.	Nom.	Max.	Min.	Nom.	Max.
A	-	-	1.45	-	-	0.057
A1	0	-	0.15	0	0.003	0.006
A2	0.9	1.1	1.3	0.035	0.043	0.051
b	0.3	0.4	0.5	0.012	0.016	0.02
C	0.08	-	0.22	0.003	0.006	0.009
D	2.7	2.9	3.1	0.106	0.114	0.122
E1	1.4	1.6	1.8	0.055	0.063	0.071
E	2.6	2.8	3	0.102	0.11	0.118
L	0.3	0.45	0.6	0.012	0.018	0.024
L1	0.5	0.6	0.7	0.02	0.024	0.028
e1	1.9 BSC			0.075 BSC		
e	0.95 BSC			0.037 BSC		
θ	0°	4°	8°	0°	4°	8°

JEDEC outline: MO-178 AB

❖ Carrier tape dimension

SOT-23-6L

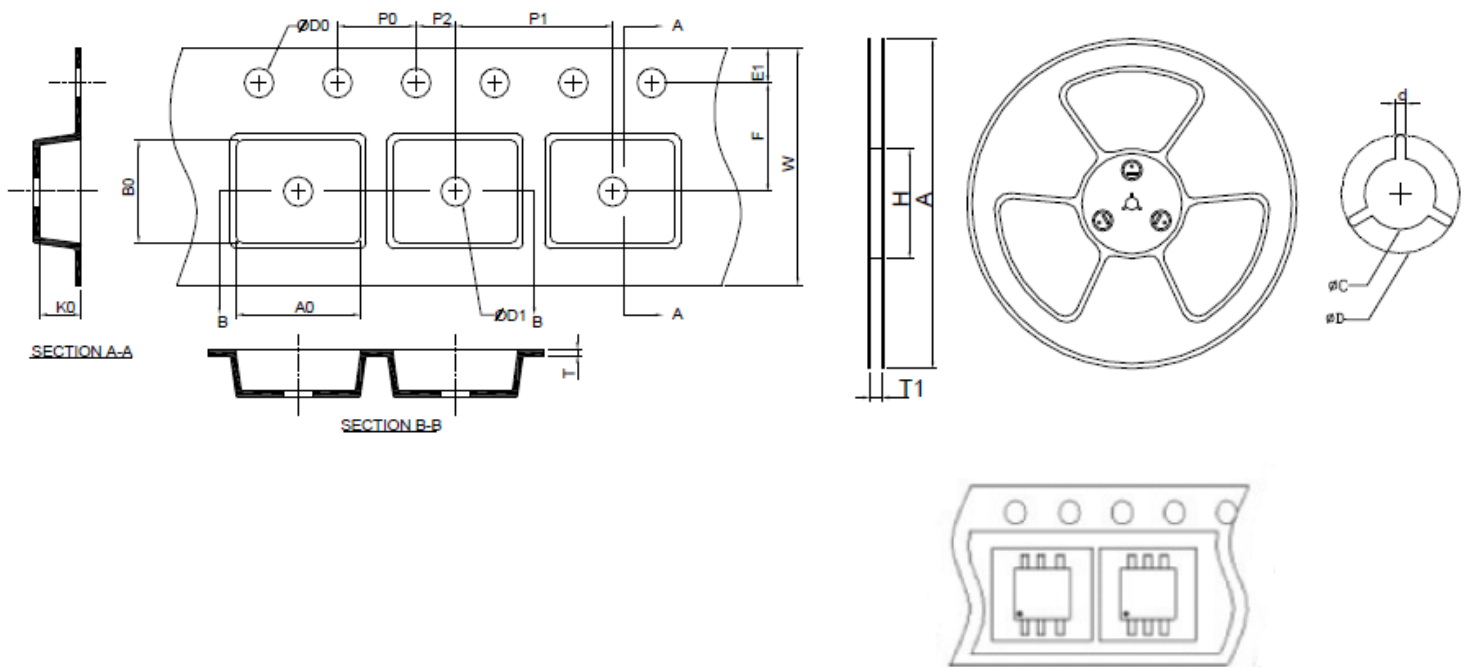

A	H	T1	C	d	D	W	E1	F
178.0±2.00	50 MIN.	8.4+2.00 -0.00	13.0+0.50 -0.20	1.5 MIN.	20.2 MIN.	8.0±0.30	1.75±0.10	3.5±0.05
P0	P1	P2	D0	D1	T	A0	B0	K0
4.0±0.10	4.0±0.10	2.0±0.05	1.5+0.10 -0.00	1.0 MIN.	0.6+0.00 -0.40	3.20±0.20	3.10±0.20	1.50±0.20

(mm)